

2015
WRX / WRX STI



Owner's Manual



Foreword

Congratulations on choosing a SUBARU vehicle. This Owner's Manual has all the information necessary to keep your SUBARU in excellent condition and to properly maintain the emission control system for minimizing emission pollutants. We urge you to read this manual carefully so that you may understand your vehicle and its operation. For information not found in this Owner's Manual, such as details concerning repairs or adjustments, please contact the SUBARU dealer from whom you purchased your SUBARU or the nearest SUBARU dealer.

The information, specifications and illustrations found in this manual are those in effect at the time of printing. FUJI HEAVY INDUSTRIES LTD. reserves the right to change specifications and designs at any time without prior notice and without incurring any obligation to make the same or similar changes on vehicles previously sold. This Owner's Manual applies to all models and covers all equipment, including factory installed options. Some explanations, therefore may be for equipment not installed in your vehicle.

Please leave this manual in the vehicle at the time of resale. The next owner will need the information found herein.

FUJI HEAVY INDUSTRIES LTD., TOKYO, JAPAN

 **SUBARU** is a registered trademark of FUJI HEAVY INDUSTRIES LTD.

© Copyright 2014 FUJI HEAVY INDUSTRIES LTD.

This manual describes the following vehicle types.

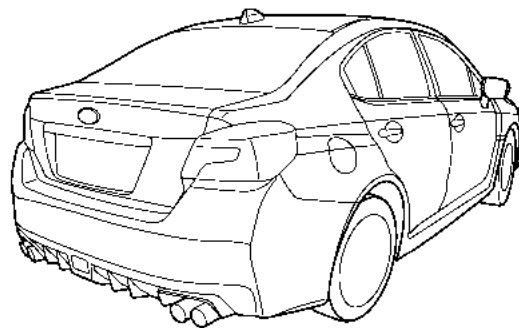
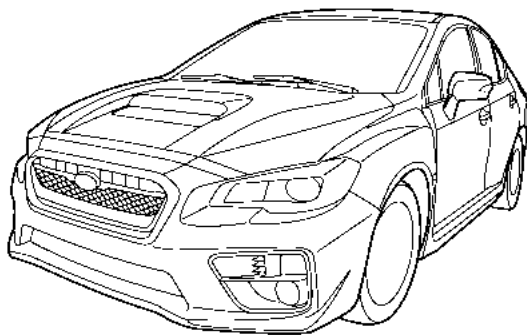

000950

Warranties

■ Warranties for U.S.A.

All SUBARU vehicles distributed by Subaru of America, Inc. and sold at retail by an authorized SUBARU dealer in the United States come with the following warranties:

- SUBARU Limited Warranty
- Emission Control Systems Warranty
- Emissions Performance Warranty

All warranty information, including details of coverage and exclusions, is in the "Warranty and Maintenance Booklet". Please read these warranties carefully.

■ Warranties for Canada

All SUBARU vehicles distributed by Subaru Canada, Inc. and sold at retail by an authorized SUBARU dealer in Canada come with the following warranties:

- SUBARU Limited Warranty
- Anti-Corrosion Warranty
- Emission Control Warranty

All warranty information, including details of coverage and exclusions, is in the "Warranty and Service Booklet". Please read these warranties carefully.

How to use this Owner's Manual

■ Using your Owner's Manual

Before you operate your vehicle, carefully read this manual. To protect yourself and extend the service life of your vehicle, follow the instructions in this manual. Failure to observe these instructions may result in serious injury and damage to your vehicle.

This manual is composed of fourteen chapters. Each chapter begins with a brief table of contents, so you can usually tell at a glance if that chapter contains the information you want.

Chapter 1: Seat, seatbelt and SRS airbags

This chapter informs you how to use the seat and seatbelt and contains precautions for the SRS airbags.

Chapter 2: Keys and doors

This chapter informs you how to operate the keys, locks and windows.

Chapter 3: Instruments and controls

This chapter informs you about the operation of instrument panel indicators and how to use the instruments and other switches.

Chapter 4: Climate control

This chapter informs you how to operate the climate control.

Chapter 5: Audio

This chapter informs you how to operate your audio system.

Chapter 6: Interior equipment

This chapter informs you how to operate interior equipment.

Chapter 7: Starting and operating

This chapter informs you how to start and operate your SUBARU.

Chapter 8: Driving tips

This chapter informs you how to drive your SUBARU in various conditions and explains some safety tips on driving.

Chapter 9: In case of emergency

This chapter informs you what to do if you have a problem while driving, such as a flat tire or engine overheating.

Chapter 10: Appearance care

This chapter informs you how to keep your SUBARU looking good.

Chapter 11: Maintenance and service

This chapter informs you when you need to take your SUBARU to the dealer for scheduled maintenance and informs you how to keep your SUBARU running properly.

Chapter 12: Specifications

This chapter informs you about dimensions and capacities of your SUBARU.

Chapter 13: Consumer information and Reporting safety defects

This chapter informs you about Uniform tire quality grading standards and Reporting safety defects.

Chapter 14: Index

This is an alphabetical listing of all that's in this manual. You can use it to quickly find something you want to read.

■ Safety warnings

You will find a number of WARNINGS, CAUTIONS and NOTES in this manual.

These safety warnings alert you to potential hazards that could result in injury to you or others.

Please read these safety warnings as well as all other portions of this manual carefully in order to gain a better understanding of how to use your SUBARU vehicle safely.



WARNING

A WARNING indicates a situation in which serious injury or death could result if the warning is ignored.



CAUTION

A CAUTION indicates a situation in which injury or damage to your vehicle, or both, could result if the caution is ignored.

NOTE

A NOTE gives information or suggestions how to make better use of your vehicle.

■ Safety symbol

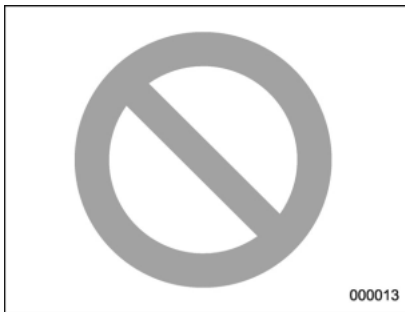

You will find a circle with a slash through it in this manual. This symbol means "Do not", "Do not do this", or "Do not let this happen", depending upon the context.

■ Abbreviation list

You may find several abbreviations in this manual. The meanings of the abbreviations are shown in the following list.



Abbreviation	Meaning
A/C	Air conditioner
A/ELR	Automatic/Emergency locking retractor
ABS	Anti-lock brake system
AKI	Anti knock index
ALR	Automatic locking retractor
AWD	All-wheel drive
CVT	Continuously variable transmission
C.DIFF/ DCCD	Driver's control center differential
DRL	Daytime running light
EBD	Electronic brake force distribution
ELR	Emergency locking retractor
GAW	Gross axle weight
GAWR	Gross axle weight rating
GPS	Global positioning system
GVW	Gross vehicle weight
GVWR	Gross vehicle weight rating
INT	Intermittent

Abbreviation	Meaning
LATCH	Lower anchors and tethers for children
LED	Light emitting diode
LSD	Limited slip differential
MIL	Malfunction indicator light
MMT	Methylcyclopentadienyl manganese tricarbonyl
MT	Manual transmission
OBD	On-board diagnostics
RON	Research octane number
SI-DRIVE	SUBARU Intelligent Drive
SRS	Supplemental restraint system
TIN	Tire identification number
TPMS	Tire pressure monitoring system

Vehicle symbols

These are some of the symbols you may see on your vehicle.

For warning and indicator lights, refer to "Warning and indicator lights"  20.

Mark	Name
	WARNING
	CAUTION

Safety precautions when driving

■ Seatbelt and SRS airbag

WARNING

- All persons in the vehicle should fasten their seatbelts **BEFORE** the vehicle starts to move. Otherwise, the possibility of serious injury becomes greater in the event of a sudden stop or accident.
- To obtain maximum protection in the event of an accident, the driver and all passengers in the vehicle should always wear seatbelts when the vehicle is moving. The SRS (Supplemental Restraint System) airbag does not do away with the need to fasten seatbelts. In combination with the seatbelts, it offers the best combined protection in case of a serious accident.

Not wearing a seatbelt increases the chance of severe injury or death in a crash even when the vehicle has the SRS airbag.

- The SRS airbags deploy with considerable speed and force. Occupants who are out of proper position when the SRS airbag deploys could suffer very serious injuries. Because the SRS airbag needs enough space for deployment, the driver should always sit upright and well back in the seat as far from the steering wheel as practical while still maintaining full vehicle control and the front passenger should move the seat as far back as possible and sit upright and well back in the seat.

For instructions and precautions, carefully read the following sections.

- For the seatbelt system, refer to “Seatbelts” [☞](#) 1-11.
- For the SRS airbag system, refer to “*SRS airbag (Supplemental Restraint System airbag)” [☞](#) 1-32.

■ Child safety



WARNING

- Never hold a child on your lap or in your arms while the vehicle is moving. The passenger cannot protect the child from injury in a collision, because the child will be caught between the passenger and objects inside the vehicle.
- While riding in the vehicle, infants and small children should always be placed in the REAR seat in an infant or child restraint system which is appropriate for the child’s age, height and weight. If a child is too big for a child restraint system, the child should sit in the REAR seat and be restrained using the seatbelts. According to accident statistics, children are safer when properly restrained in the rear seating positions than in the front seating positions. Never allow a child to stand up or kneel on the seat.
- Put children aged 12 and under in the REAR seat properly restrained at all times in a child restraint device or in a seatbelt.

The SRS airbag deploys with considerable speed and force and can injure or even kill children, especially if they are 12 years of age and under and are not restrained or improperly restrained. Because children are lighter and weaker than adults, their risk of being injured from deployment is greater.

- NEVER INSTALL A REARWARD FACING CHILD SEAT IN THE FRONT SEAT. DOING SO RISKS SERIOUS INJURY OR DEATH TO THE CHILD BY PLACING THE CHILD’S HEAD TOO CLOSE TO THE SRS AIRBAG.
- Always turn the child safety locks to the “LOCK” position when children sit in the rear seat. Serious injury could result if a child accidentally opens the door and falls out. Refer to “Child safety locks” [☞](#) 2-28.
- Always lock the passenger’s windows using the lock switch when children are riding in the vehicle. Failure to follow this procedure could result in injury to a child operating the power window. Refer to “Windows” [☞](#) 2-28.

- Never leave unattended children, adults or animals in the vehicle. They could accidentally injure themselves or others through inadvertent operation of the vehicle. Also, on hot or sunny days, temperature in a closed vehicle could quickly become high enough to cause severe or possibly fatal injuries to them.
- When leaving the vehicle, close all windows and lock all doors.

For instructions and precautions, carefully read the following sections.

- For the seatbelt system, refer to “Seatbelts” ☞ 1-11.
- For the child restraint system, refer to “Child restraint systems” ☞ 1-20.
- For the SRS airbag system, refer to “SRS airbag (Supplemental Restraint System airbag)” ☞ 1-32.

■ Engine exhaust gas (carbon monoxide)

WARNING

- Never inhale engine exhaust gas. Engine exhaust gas contains carbon monoxide, a colorless and odorless gas which is dan-

gerous, or even lethal, if inhaled.

- Always properly maintain the engine exhaust system to prevent engine exhaust gas from entering the vehicle.
- Never run the engine in a closed space, such as a garage, except for the brief time needed to drive the vehicle in or out of it.
- Avoid remaining in a parked vehicle for a lengthy time while the engine is running. If that is unavoidable, then use the ventilation fan to force fresh air into the vehicle.
- Always keep the front ventilator inlet grille free from snow, leaves or other obstructions to ensure that the ventilation system always works properly.
- If at any time you suspect that exhaust fumes are entering the vehicle, have the problem checked and corrected as soon as possible. If you must drive under these conditions, drive only with all windows fully open.
- Keep the trunk lid closed while driving to prevent exhaust gas from entering the vehicle.

■ Drinking and driving

WARNING

Drinking and then driving is very dangerous. Alcohol in the bloodstream delays your reaction time and impairs your perception, judgment and attentiveness. If you drive after drinking – even if you drink just a little – it will increase the risk of being involved in a serious or fatal accident, injuring or killing yourself, your passengers and others. In addition, if you are injured in the accident, alcohol may increase the severity of that injury.

Please don't drink and drive.

Drunken driving is one of the most frequent causes of accidents. Since alcohol affects all people differently, you may have consumed too much alcohol to drive safely even if the level of alcohol in your blood is below the legal limit. The safest thing you can do is never drink and drive. However if you have no choice but to drive, stop drinking and sober up completely before getting behind the wheel.

■ Drugs and driving

WARNING

There are some drugs (over the counter and prescription) that can delay your reaction time and impair your perception, judgment and attentiveness. If you drive after taking them, it may increase your, your passengers' and other persons' risk of being involved in a serious or fatal accident.

If you are taking any drugs, check with your doctor or pharmacist or read the literature that accompanies the medication to determine if the drug you are taking can impair your driving ability. Do not drive after taking any medications that can make you drowsy or otherwise affect your ability to safely operate a motor vehicle. If you have a medical condition that requires you to take drugs, please consult with your doctor.

Never drive if you are under the influence of any illicit mind-altering drugs. For your own health and well-being, we urge you not to take illegal drugs in the first place and to seek treatment if you are addicted to those drugs.

■ Driving when tired or sleepy

WARNING

When you are tired or sleepy, your reaction time will be delayed and your perception, judgment and attentiveness will be impaired. If you drive when tired or sleepy, your, your passengers' and other persons' chances of being involved in a serious accident may increase.

Please do not continue to drive but instead find a safe place to rest if you are tired or sleepy. On long trips, you should make periodic rest stops to refresh yourself before continuing on your journey. When possible, you should share the driving with others.

■ Modification of your vehicle

CAUTION

Your vehicle should not be modified other than with genuine SUBARU parts and accessories. Other types of modifications could affect its performance, safety or durability, and may even violate governmental regulations. In addition, damage or

performance problems resulting from modification may not be covered under warranties.

NOTE

This vehicle is equipped with a function that will record certain vehicle data in the event the vehicle is operated or maintained in a manner that exceeds or varies from routine normal use.

That data may be used as a means of determining whether or not a vehicle condition is eligible for repair under warranty.

■ Car phone/cell phone and driving

CAUTION

Do not use a car phone/cell phone while driving; it may distract your attention from driving and can lead to an accident. If you use a car phone/cell phone, pull off the road and park in a safe place before using your phone. In some States/Provinces, only hands-free phones may legally be used while driving.

■ Driving vehicles equipped with navigation system

WARNING

Do not allow the monitor to distract your attention from driving. Also, do not operate the controls of the navigation system while driving. The loss of attention to driving could lead to an accident. If you wish to operate the controls of the navigation system, first take the vehicle off the road and stop it in a safe place.

■ Driving with pets

Unrestrained pets can interfere with your driving and distract your attention from driving. In a collision or sudden stop, unrestrained pets or cages can be thrown around inside the vehicle and hurt you or your passengers. Besides, the pets can be hurt under these situations. It is also for their own safety that pets should be properly restrained in your vehicle. Restrain a pet with a special traveling harness which can be secured to the rear seat with a seatbelt or use a pet carrier which can be secured to the rear seat by routing a seatbelt through the carrier's

handle. Never restrain pets or pet carriers in the front passenger's seat. For further information, consult your veterinarian, local animal protection society or pet shop.

■ Tire pressures

Check and, if necessary, adjust the pressure of each tire (including the spare) at least once a month and before any long journey.

Check the tire pressure when the tires are cold. Use a pressure gauge to adjust the tire pressures to the values shown on the tire placard. For detailed information, refer to "Tires and wheels" 11-30.

WARNING

Driving at high speeds with excessively low tire pressures can cause the tires to deform severely and to rapidly become hot. A sharp increase in temperature could cause tread separation, and destruction of the tires. The resulting loss of vehicle control could lead to an accident.

General information

■ California proposition 65 warning

WARNING

Engine exhaust, some of its constituents, and certain vehicle components contain or emit chemicals known to the State of California to cause cancer and birth defects or other reproductive harm. In addition, certain fluids in vehicles and certain components of product wear contain or emit chemicals known to the State of California to cause cancer and birth defects or other reproductive harm.

■ California Perchlorate Advisory

Certain vehicle components such as air-bag modules, seatbelt pretensioners and keyless entry transmitter batteries may contain perchlorate material. Special handling may apply for service or vehicle end of life disposal. See www.dtsc.ca.gov/hazardouswaste/perchlorate.

■ Noise from under the vehicle

NOTE

You may hear a noise from under the vehicle approximately 5 to 10 hours after the engine is turned off. However, this does not indicate a malfunction. This noise is caused by the operation of the fuel evaporation leakage checking system and is normal. The noise will stop after approximately 15 minutes.

■ Event data recorder

This vehicle is equipped with an event data recorder (EDR). The main purpose of an EDR is to record, in certain crash or near crash-like situations, such as an air bag deployment or hitting a road obstacle, data that will assist in understanding how a vehicle's systems performed. The EDR is designed to record data related to vehicle dynamics and safety systems for a short period of time, typically 30 seconds or less. The EDR in this vehicle is designed to record such data as:

- How various systems in your vehicle were operating;
- Whether or not the driver and passenger safety belts were buckled/fastened;
- How far (if at all) the driver was depressing the accelerator and/or brake

pedal; and,

- How fast the vehicle was traveling.

These data can help provide a better understanding of the circumstances in which crashes and injuries occur. NOTE: EDR data are recorded by your vehicle only if a non-trivial crash situation occurs; no data are recorded by the EDR under normal driving conditions and no personal data (e.g., name, gender, age, and crash location) are recorded. However, other parties, such as law enforcement, could combine the EDR data with the type of personally identifying data routinely acquired during a crash investigation.

To read data recorded by an EDR, special equipment is required, and access to the vehicle or the EDR is needed. In addition to the vehicle manufacturer, other parties, such as law enforcement, that have the special equipment, can read the information if they have access to the vehicle or the EDR.

Table of contents

<i>Seat, seatbelt and SRS airbags</i>	1
<i>Keys and doors</i>	2
<i>Instruments and controls</i>	3
<i>Climate control</i>	4
<i>Audio</i>	5
<i>Interior equipment</i>	6
<i>Starting and operating</i>	7
<i>Driving tips</i>	8
<i>In case of emergency</i>	9
<i>Appearance care</i>	10
<i>Maintenance and service</i>	11
<i>Specifications</i>	12
<i>Consumer information and Reporting safety defects</i>	13
<i>Index</i>	14

Illustrated index

■ Exterior

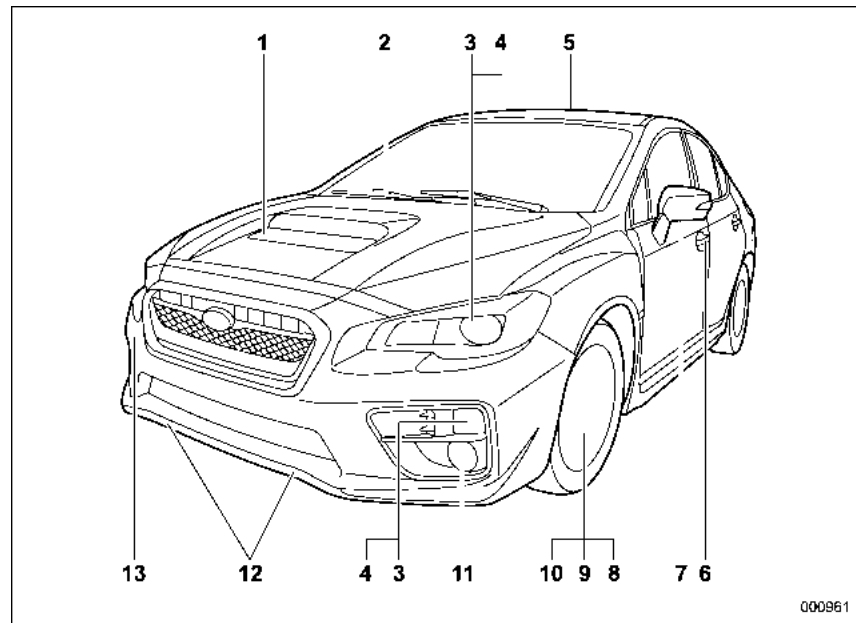

- 1) Engine hood (page 11-8)
- 2) Wiper switch (page 3-104)
- 3) Headlight switch (page 3-99)
- 4) Replacing bulbs (page 11-43)
- 5) Moonroof (page 2-34)
- 6) Door locks (page 2-4)
- 7) Outside mirrors (page 3-113)
- 8) Tire pressure (page 11-32)
- 9) Flat tires (page 9-4)
- 10) Snow tires (page 8-9)
- 11) Fog light switch (page 3-102)
- 12) Tie-down hooks (page 9-12)
- 13) Towing hook (page 9-12)

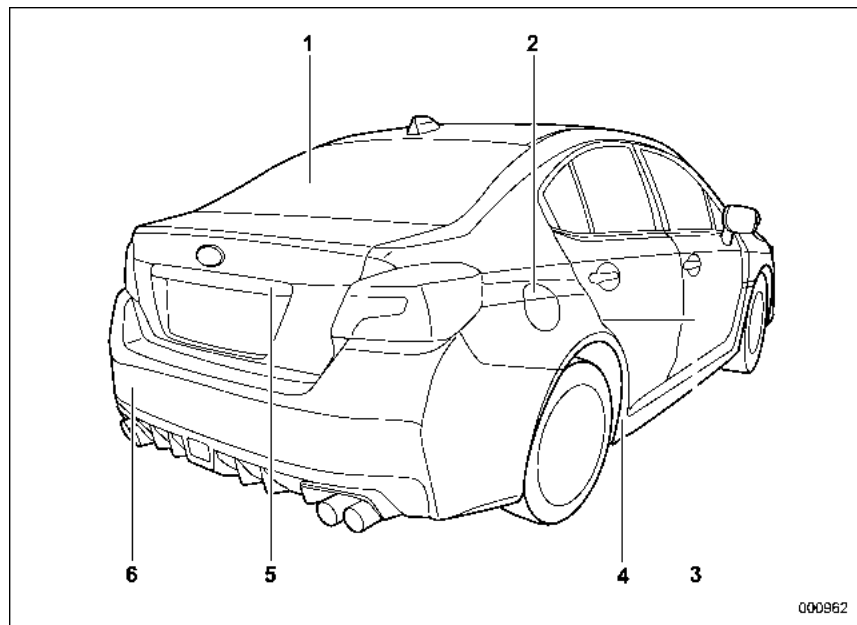

- 1) Rear window defogger (page 3-114)
- 2) Fuel filler lid and cap (page 7-5)
- 3) Child safety locks (page 2-28)
- 4) Tie-down hole (page 9-12)
- 5) Trunk lid (page 2-32)
- 6) Towing hook (page 9-12)

000962

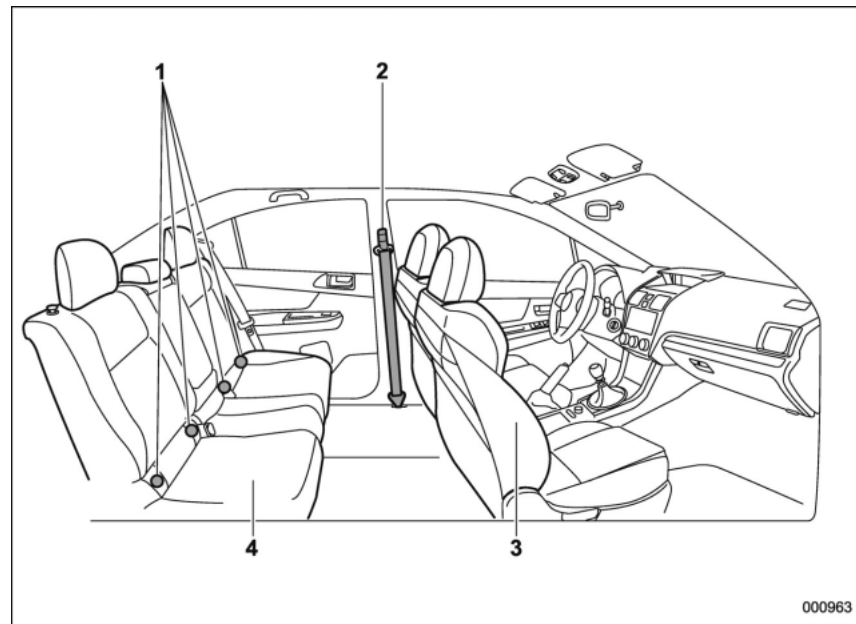
■ Interior**▼ Passenger compartment area**

- 1) Lower anchorages for child restraint system (page 1-28)
- 2) Seatbelt (page 1-11)
- 3) Front seat (page 1-2)
- 4) Rear seat (page 1-7)

000963

(STI)

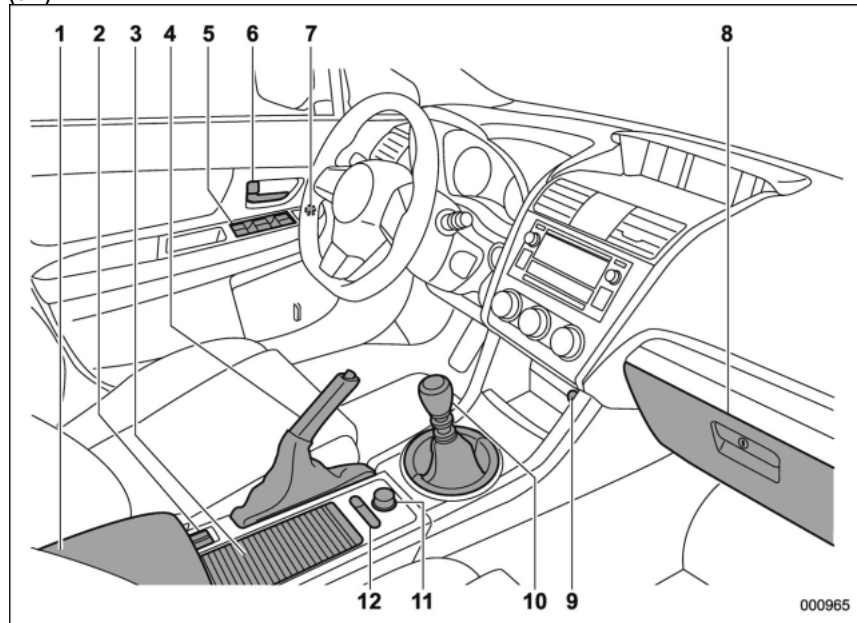

- 1) Center console (page 6-5)
- 2) Seat heater (page 1-6)
- 3) Cup holder (page 6-5)
- 4) Parking brake lever (page 7-43)
- 5) Power windows (page 2-28)
- 6) Door locks (page 2-4)
- 7) Outside mirror switch (page 3-113)
- 8) Glove box (page 6-4)
- 9) Front power supply socket (page 6-7)
- 10) Shift lever (page 7-16)
- 11) SI-DRIVE (page 7-28)
- 12) Driver's Control Center Differential (C.DIFF/DCCD) (page 7-19)

(Except STI)

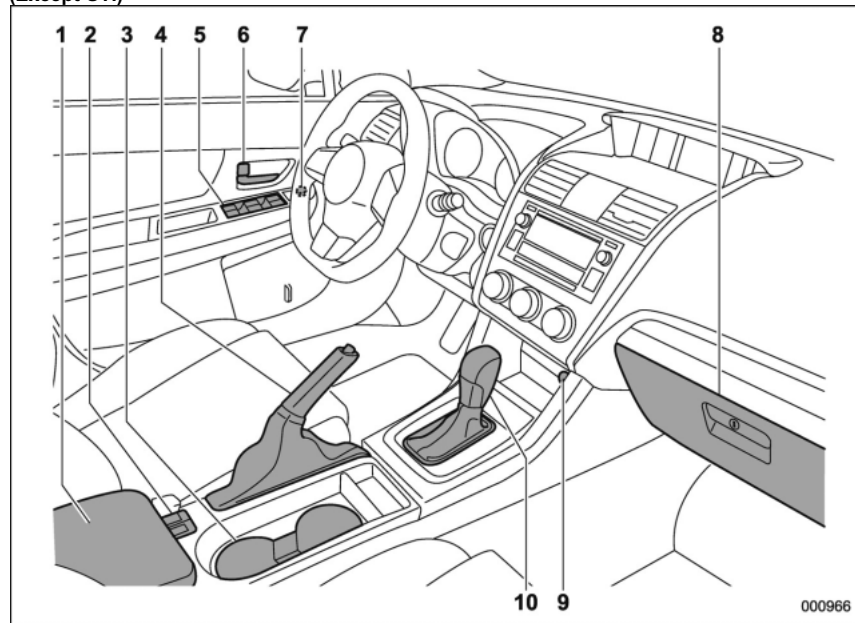

- 1) Center console (page 6-5)
- 2) Seat heater (page 1-6)
- 3) Cup holder (page 6-5)
- 4) Parking brake lever (page 7-43)
- 5) Power windows (page 2-28)
- 6) Door locks (page 2-4)
- 7) Outside mirror switch (page 3-113)
- 8) Glove box (page 6-4)
- 9) Front power supply socket (page 6-7)
- 10) Shift lever (MT) (page 7-16)/Select lever (CVT) (page 7-24)

000966

■ Instrument panel

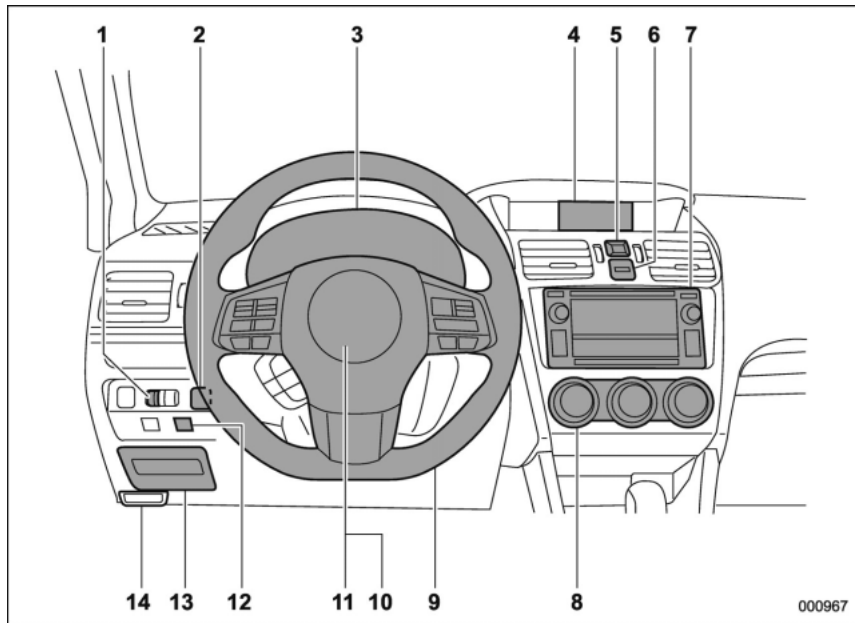

- 1) Illumination brightness control (page 3-101)
- 2) Trunk lid opener switch (page 2-32)
- 3) Combination meter (page 3-8)
- 4) Multi function display (page 3-45)
- 5) Hazard warning flasher switch (page 3-8)
- 6) Multi function display control switches (page 3-45)
- 7) Audio (page 5-1)
- 8) Climate control (page 4-1)
- 9) Tilt/telescopic steering (page 3-115)
- 10) Horn (page 3-116)
- 11) SRS airbag (page 1-32)
- 12) Vehicle Dynamics Control OFF switch (page 7-40)
- 13) Fuse box (page 11-41)
- 14) Hood lock release knob (page 11-8)

000967

■ Steering wheel

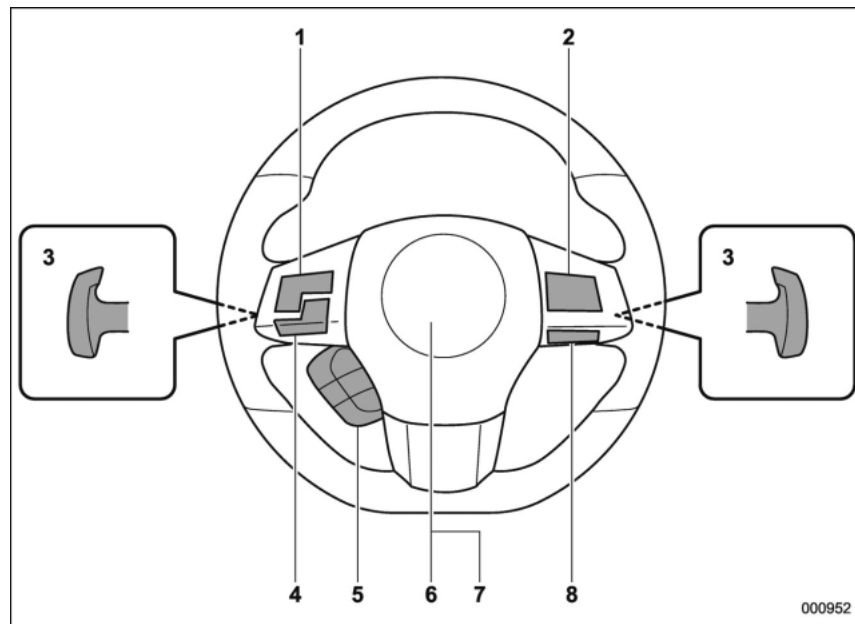

- 1) Audio control buttons (page 5-31)
- 2) Cruise control (page 7-47)
- 3) Shift paddle (page 7-25)
- 4) Hands-free switches (page 5-36)
- 5) Multi information display control switches (page 3-34)
- 6) SRS airbag (page 1-32)
- 7) Horn (page 3-116)
- 8) SI-DRIVE switches (except STI) (page 7-32)

■ Light control and wiper control levers/switches

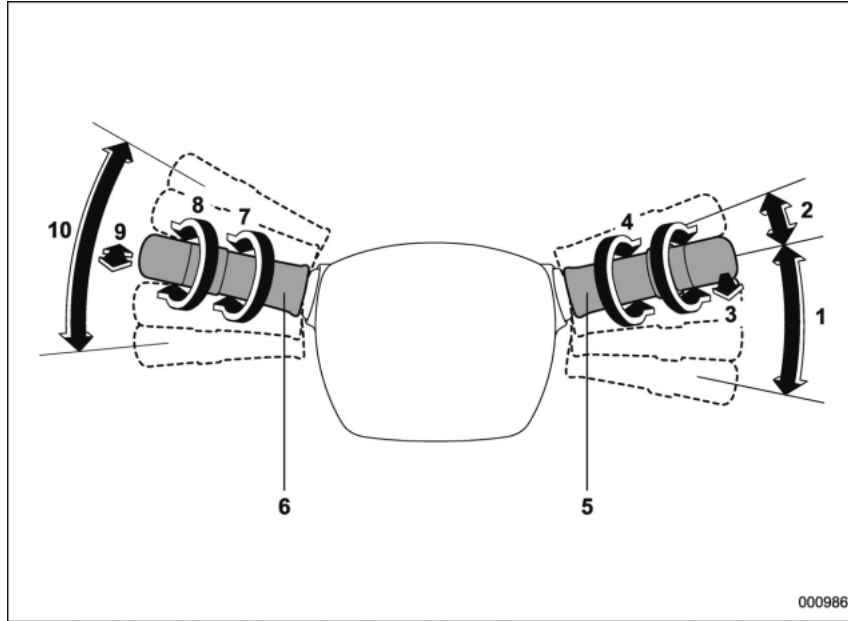

- 1) Windshield wiper (page 3-103)
- 2) Mist (page 3-104)
- 3) Windshield washer (page 3-105)
- 4) Wiper intermittent time control switch (page 3-105)
- 5) Wiper control lever (page 3-104)
- 6) Light control switch (page 3-98)
- 7) Fog light switch (page 3-102)
- 8) Headlight ON/OFF/AUTO (page 3-99)
- 9) Headlight flasher High/Low beam change (page 3-100)
- 10) Turn signal lever (page 3-101)

■ Combination meter

▼ U.S.-spec. models

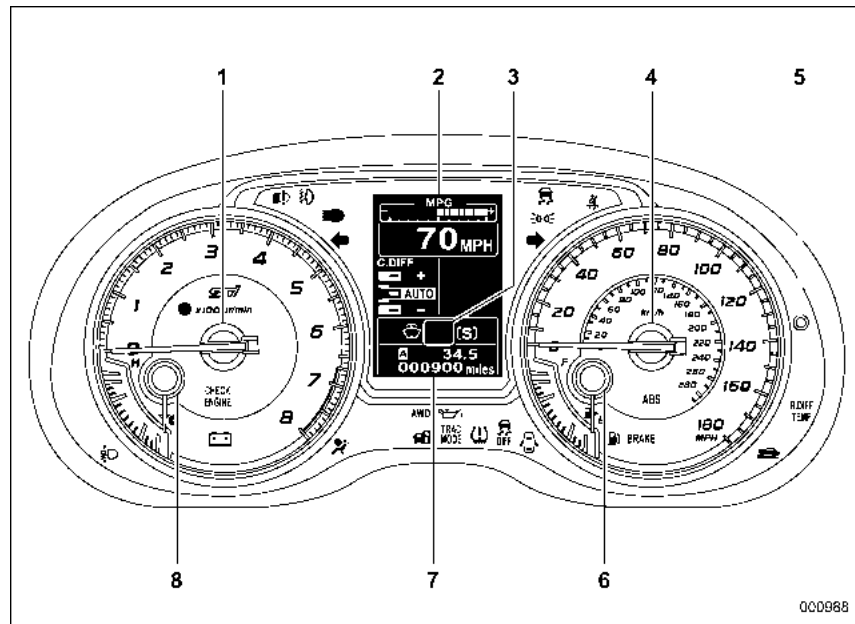

- 1) Tachometer (page 3-10)
- 2) Multi information display (page 3-34)
- 3) Select lever/gear position indicator (page 3-31)
- 4) Speedometer (page 3-9)
- 5) Trip knob (page 3-9)
- 6) Fuel gauge (page 3-10)
- 7) Trip meter and odometer (page 3-9)
- 8) Temperature gauge (page 3-11)

The illustration above is a typical example. For some models, the combination meter may be slightly different than that shown in the illustration.



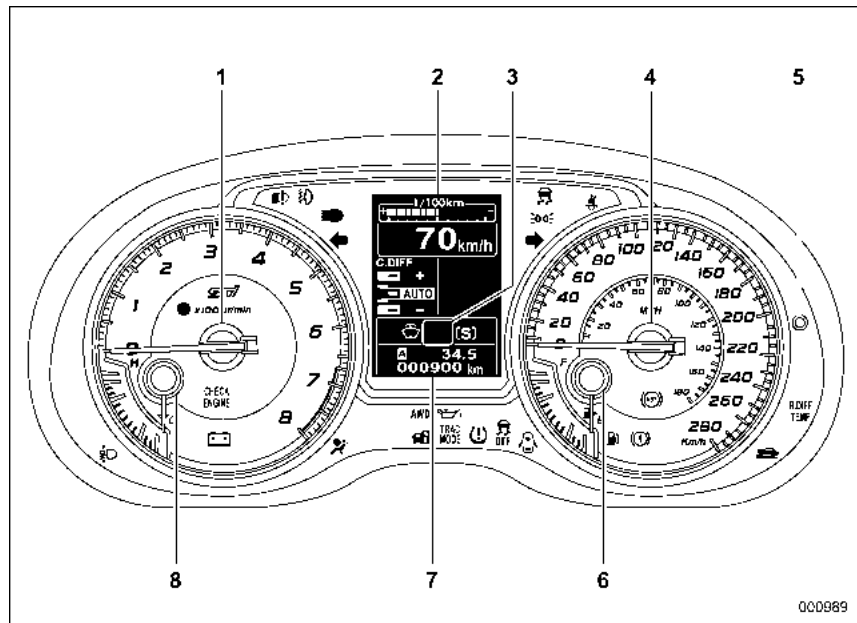







▼ Except U.S.-spec. models























- 1) Tachometer (page 3-10)
- 2) Multi information display (page 3-34)
- 3) Select lever/gear position indicator (page 3-31)
- 4) Speedometer (page 3-9)
- 5) Trip knob (page 3-9)
- 6) Fuel gauge (page 3-10)
- 7) Trip meter and odometer (page 3-9)
- 8) Temperature gauge (page 3-11)











The illustration above is a typical example. For some models, the combination meter may be slightly different than that shown in the illustration.

■ Warning and indicator lights

Mark	Name	Page
	Seatbelt warning light	3-13
PASSENGER 	Front passenger's seatbelt warning light	3-13
	SRS airbag system warning light	3-15
ON / 	Front passenger's frontal airbag ON indicator	3-15
OFF / 	Front passenger's frontal airbag OFF indicator	3-15
CHECK ENGINE 	CHECK ENGINE warning light/Malfunction indicator light	3-16
	Charge warning light	3-17
	Oil pressure warning light	3-17
	Engine oil level warning indicator (except STI)	3-17
AT OIL TEMP 	AT OIL TEMP warning light (CVT models)	3-18

Mark	Name	Page
R.DIFF TEMP 	Rear differential oil temperature warning light (STI)	3-18
ABS / 	ABS warning light	3-20
BRAKE / 	Brake system warning light	3-20
	Door open warning light	3-22
AWD 	AWD warning light (if equipped)	3-22
	Power steering warning light (except STI)	3-22
	Hill start assist warning light/Hill start assist OFF indicator light	3-22
	Vehicle Dynamics Control warning light/Vehicle Dynamics Control operation indicator light	3-23
	Vehicle Dynamics Control OFF indicator light	3-25
	Turn signal indicator lights	3-32

Mark	Name	Page
	LED headlight warning light (if equipped)	3-23
	High beam indicator light	3-32
	Automatic headlight beam leveler warning light (if equipped)	3-32
	Front fog light indicator light (if equipped)	3-32
	Access key warning light (if equipped)	3-26
	Security indicator light	3-30
	Headlight indicator light	3-32
	Cruise control indicator	3-32
SET 	Cruise control set indicator	3-32
TRAC MODE 	Traction mode indicator	3-25
	Low fuel warning light	3-21

Mark	Name	Page
	Low tire pressure warning light (U.S.-spec. models)	3-18
	Windshield washer fluid warning indicator	3-17
	Sport (S) mode indicator (if equipped)	3-31
	Intelligent (I) mode indicator (if equipped)	3-31
	Sport Sharp (S#) mode indicator (if equipped)	3-31
	Shift-up indicator (STI)	3-31
	Driver's control center differential auto indicator (STI)	3-32
	Auto [+] mode indicator (STI)	3-33
	Auto [-] mode indicator (STI)	3-33
	Driver's control center differential indicator and warning (STI)	3-33
	REV indicator light (STI)	3-34

Function settings

A SUBARU dealer can change the settings of the functions shown in the following table to meet your personal requirements. Contact the nearest SUBARU dealer for details. For details, refer to "Multi function display" 3-45.

Item	Function	Possible settings	Default setting
Alarm system	Alarm system	Operation/Non-operation	Operation
	Monitoring start delay time (after closure of doors)	0 seconds/30 seconds	30 seconds
	Impact sensor operation (only models with shock sensors (dealer option))	Operation/Non-operation	Non-operation
	Passive arming (models without "keyless access with push-button start system")	Operation/Non-operation	Non-operation
	Dome light and map lights (models with moonroof) illumination	ON/OFF	OFF
Keyless access (if equipped)	Hazard warning flasher*	Operation/Non-operation	Operation
	Audible signal*	Operation/Non-operation	Operation
	Volume of the audible signal	1 - 7	5
	Door unlock selection function (driver's door unlock)	Driver's door only/All doors	Driver's door only
Remote keyless entry system	Hazard warning flasher*	Operation/Non-operation	Operation
	Audible signal*	Operation/Non-operation	Operation
	Volume of the audible signal	1 - 7	5
Key lock-in prevention	Key lock-in prevention	Operation/Non-operation	Operation
Defogger and deicer system for models with the automatic climate control system*	Rear window defogger, outside mirror defogger and windshield wiper deicer	Operation for 15 minutes/ Continuous operation	Operation for 15 minutes
Dome light	Operation of dome light/map light OFF delay timer	OFF/10 seconds/20 seconds/30 seconds	30 seconds
Map light (models with moonroof)			
Battery drainage prevention function	Battery drainage prevention function	Operation/Non-operation	Operation

Item	Function	Possible settings	Default setting
Seatbelt warning	Sounds a chime while driving	Operation/Non-operation	Operation
Auto on/off headlights (if equipped)*	Sensitivity of the operation of the auto on/off headlights	Low/Normal/High/Very high	Normal
Welcome lighting	Approaching (operation of timer)	OFF/30 seconds/60 seconds/90 seconds	30 seconds
	Exiting (operation of timer)		

*: The settings can be changed by the customer using the multi function display.

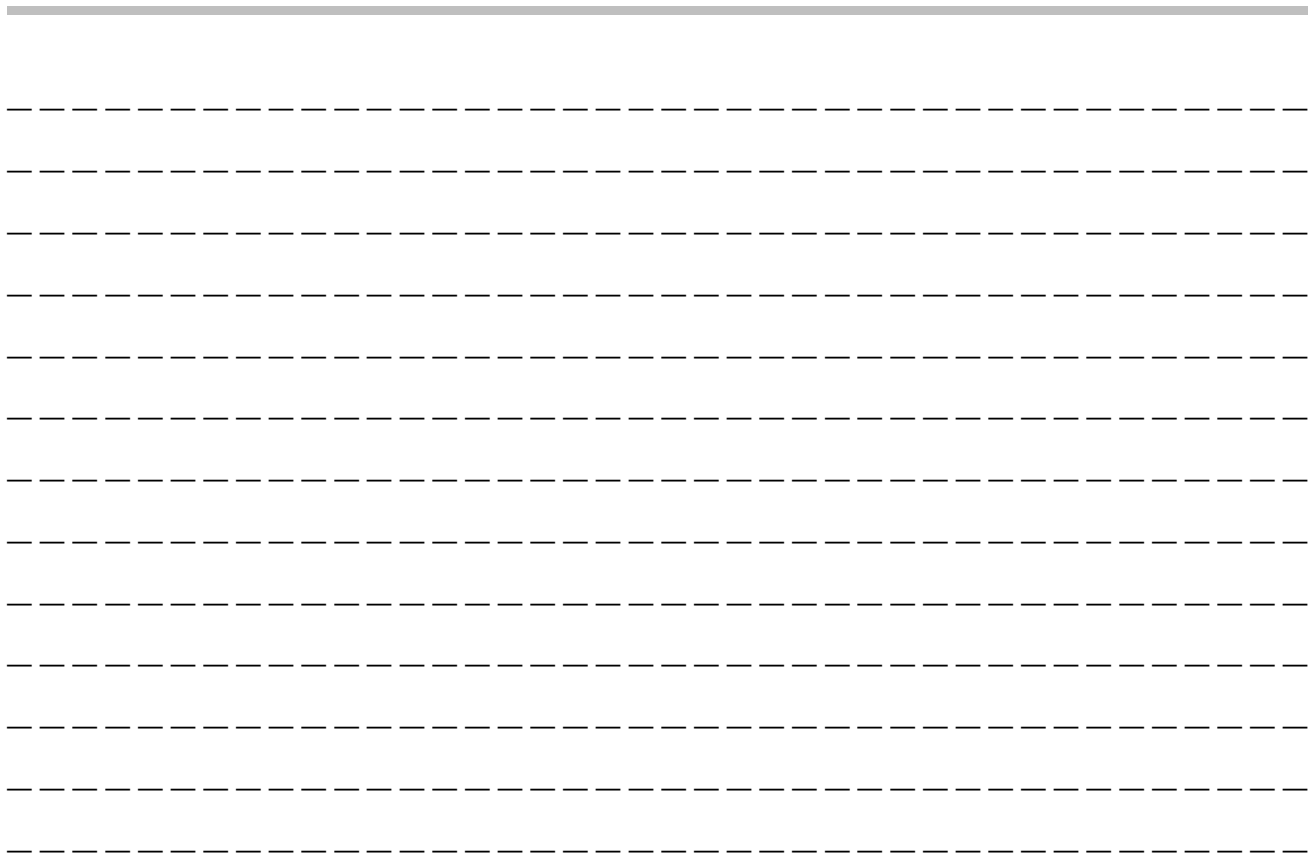

Seat, seatbelt and SRS airbags

Front seats.....	1-2	Precautions against vehicle modification.....	1-20
Manual seat	1-4	Child restraint systems	1-20
Power seat (driver's seat – if equipped)	1-5	Where to place a child restraint system.....	1-22
Head restraint adjustment.....	1-5	Choosing a child restraint system	1-23
Seat heater (if equipped)	1-6	Installing child restraint systems with A/ELR seatbelt	1-23
Rear seats.....	1-7	Installing a booster seat.....	1-27
Head restraint adjustment.....	1-8	Installation of child restraint systems by use of lower and tether anchorages (LATCH)	1-28
Folding down the rear seatback.....	1-9	Top tether anchorages	1-31
Seatbelts	1-11	*SRS airbag (Supplemental Restraint System airbag).....	1-32
Seatbelt safety tips.....	1-11	Models with SRS airbags and lap/shoulder restraints for driver, front passenger, and window-side rear passengers.....	1-32
Emergency Locking Retractor (ELR)	1-12	Components	1-35
Automatic/Emergency Locking Retractor (A/ELR)	1-12	SUBARU advanced frontal airbag system	1-37
Seatbelt warning light and chime	1-13	SRS side airbag and SRS curtain airbag.....	1-49
Fastening the seatbelt	1-13	SRS airbag system monitors	1-56
Seatbelt maintenance	1-15	SRS airbag system servicing	1-57
Front seatbelt pretensioners	1-16	Precautions against vehicle modification.....	1-58
Seatbelt with shoulder belt pretensioner	1-16		
Seatbelt with shoulder belt and lap belt pretensioners.....	1-18		
System monitors	1-19		
System servicing.....	1-19		

Front seats

WARNING

- Never adjust the seat while driving to avoid losing control of the vehicle which can result in personal injury.
- Before adjusting the seat, make sure the hands and feet of rear seat passengers and cargo are clear of the adjusting mechanism.
- After adjusting the seat, push it slightly to make sure it is securely locked. If the seat is not securely locked, it may move or the seatbelt may not operate properly.
- Do not put objects under the front seats. They may interfere with front seat locking and cause an accident.
- Seatbelts provide maximum restraint when the occupant sits well back and upright in the seat. To reduce the risk of sliding under the seatbelt in a collision, the front seatbacks should be always used in the upright position while the vehicle is running.

If the front seatbacks are not used in the upright position in a collision, the risk of sliding under the lap belt and of the lap belt sliding up over the abdomen will increase, and both can result in serious internal injury or death.

- The SRS airbags deploy with considerable speed and force. Occupants who are out of proper position when the SRS airbag deploys could suffer very serious injuries. Because the SRS airbag needs enough space for deployment, the driver should always sit upright and well back in the seat as far from the steering wheel as practical while still maintaining full vehicle control and the front passenger should move the seat as far back as possible and sit upright and well back in the seat.



WARNING

Put children aged 12 and under in the rear seat properly restrained at all times. The SRS airbag deploys with considerable speed and force and can injure or even kill children, especially if they are 12 years of age and under and are not restrained or improperly restrained. Because children are lighter and weaker than adults, their risk of being injured from deployment is greater. For that reason, we strongly recommend that ALL children (including those in child seats and those that have outgrown child restraint devices) sit in the REAR seat properly restrained at all times in a child

restraint device or in a seatbelt, whichever is appropriate for the child's age, height and weight. Secure ALL types of child restraint devices (including forward facing child seat) in the REAR seats at all times.

NEVER INSTALL A REARWARD FACING CHILD SEAT IN THE FRONT SEAT. DOING SO RISKS SERIOUS INJURY OR DEATH TO THE CHILD BY PLACING THE CHILD'S HEAD TOO CLOSE TO THE SRS AIRBAG.

According to accident statistics, children are safer when properly restrained in the rear seating positions than in the front seating positions. For instructions and precautions concerning child restraint systems, refer to "Child restraint systems" 1-20.

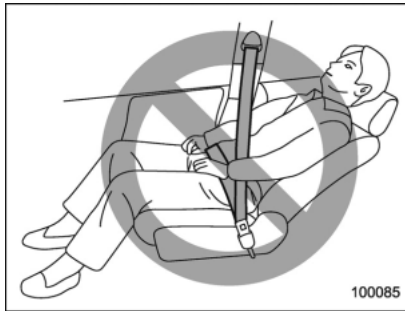

WARNING

To prevent the passenger from sliding under the seatbelt in the event of a collision, always put the seatback in the upright position while the vehicle is in motion. Also, do not place objects such as cushions between the passenger and the seatback. If you do so, the risk of sliding under the lap belt and of the lap belt sliding up over the abdomen will increase, and both can result in serious internal injury or death.

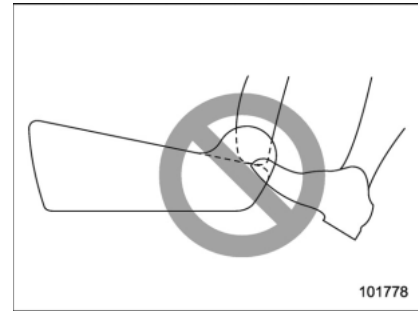

WARNING

Do not let rear passengers rest their feet between the front seatback and seat cushion. Doing so may lead to improper operation of the following systems and could result in serious injury.

- Occupant detection system
- SRS side airbag
- Seat heater (if equipped)
- Power seat (if equipped)

Manual seat

Forward and backward adjustment

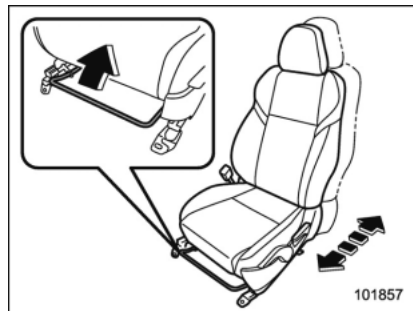

Pull the lever upward and slide the seat to the desired position. Then release the lever and try to move the seat back and forth to make sure that it is securely locked in place.

Reclining the seatback

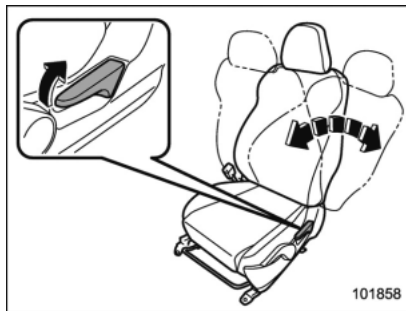

Pull the reclining lever up and adjust the seatback to the desired position. Then release the lever and make sure the seatback is securely locked into place.

The seatback placed in a reclined position can spring back upward with force when the lever is pulled. While operating the lever to return the seatback, hold the seatback lightly so that it may be raised back gradually.

Seat cushion height adjustment (driver's seat)

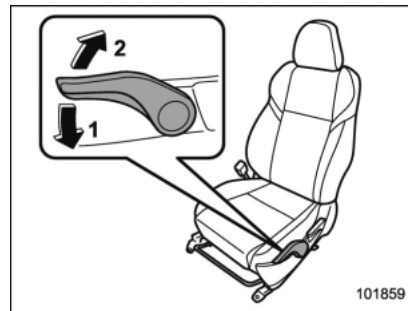

- 1) When the lever is pushed down, the seat is lowered.
- 2) When the lever is pulled up, the seat rises.

The height of the seat can be adjusted by moving the seat cushion adjustment lever up and down.

■ Power seat (driver's seat – if equipped)

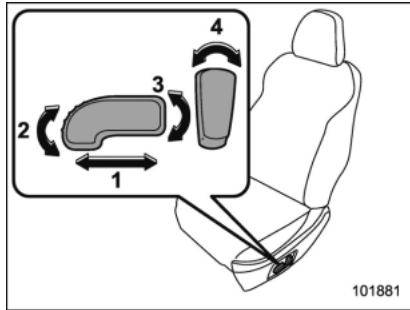

- 1) **Seat position forward/backward control switch**
To adjust the seat forward or backward, move the control switch forward or backward. During forward/backward adjustment of the seat, you cannot adjust the seat cushion angle or seat cushion height.
- 2) **Seat cushion angle control switch**
To adjust the seat cushion angle, pull up or push down the front end of the control switch.
- 3) **Seat height control switch**
To adjust the seat height, pull up or push down the rear end of the control switch.
- 4) **Seatback angle (reclining) control switch**
To adjust the angle of the seatback, move the control switch.

■ Head restraint adjustment

⚠ WARNING

- Never drive the vehicle with the head restraints removed because they are designed to reduce the risk of serious neck injury in the event that the vehicle is struck from the rear. Also, never install the head restraints the opposite way round. Doing so will prevent the head restraints from functioning as intended. Therefore, when you remove the head restraints, you must reinstall all head restraints correctly to protect vehicle occupants.
- All occupants, including the driver, should not operate a vehicle or sit in a vehicle's seat until the head restraints are placed in their proper positions in order to minimize the risk of neck injury in the event of a crash.

Both the driver's seat and front passenger's seat are equipped with head restraints. Both head restraints are adjustable in the following ways.

▼ Head restraint height adjustment

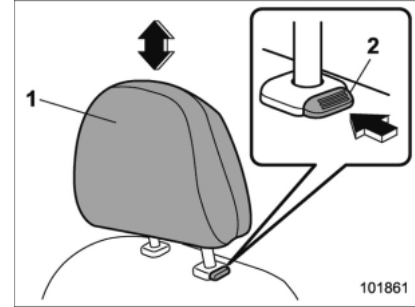

- 1) Head restraint
- 2) Release button

Each head restraint should be adjusted so that the center of the head restraint is closest to the top of the occupant's ears.

To raise:

Pull the head restraint up.

To lower:

Push the head restraint down while pressing the release button on the top of the seatback.

To remove:

While pressing the release button, pull out the head restraint.

To install:

Install the head restraint into the holes that

are located on the top of the seatback until the head restraint locks. Press and hold the release button to lower the head restraint.

▼ Head restraint angle adjustment

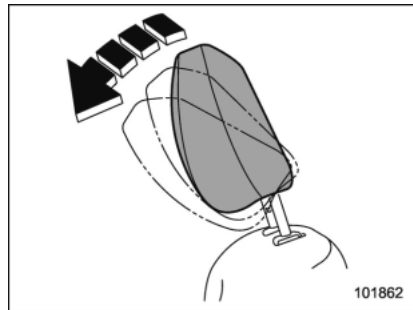

The angle of the head restraint can be adjusted in several steps. While maintaining a suitable driving posture, adjust the head restraint to a position where the back of your head is as close to the head restraint as possible.

To tilt:

Tilt the head restraint by hand to the preferred position. A click will be audible when the head restraint is locked.

To return:

Tilt the head restraint once as far forward as it can go. The head restraint will

automatically return to the fully upright position. Then, adjust the head restraint again to the preferred angle.

Seat heater (if equipped)

The front seats are equipped with a seat heater.

The seat heater operates when the ignition switch is either in the "ACC" or "ON" position.

⚠ CAUTION

- There is a possibility that people with delicate skin may suffer slight burns even at low temperatures if they use the seat heater for a long period of time. When using the heater, always be sure to warn the persons concerned.
- Do not put anything on the seat which insulates against heat, such as a blanket, cushion, or similar items. This may cause the seat heater to overheat.

NOTE

Use of the seat heater for a long period of time while the engine is not running can cause battery discharge.

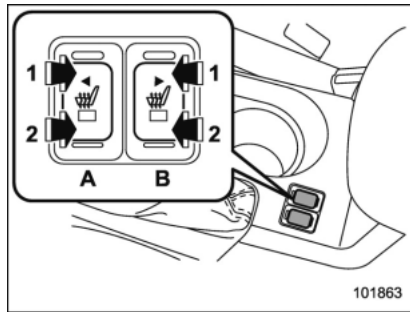
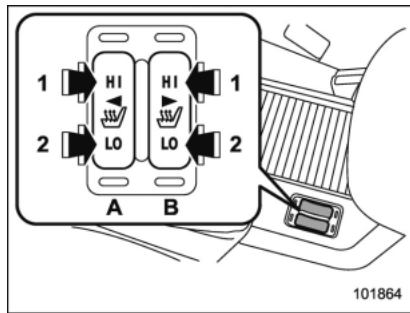
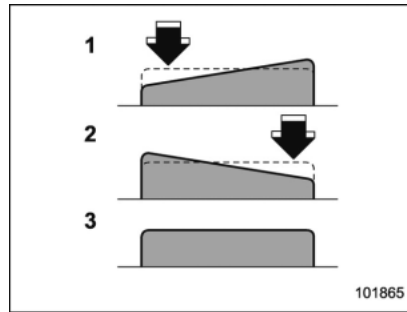
**Type A****Type B**

- 1) **HIGH (HI)** – Rapid heating
 - 2) **LOW (LO)** – Normal heating
 - 3) Off
- A) Left-hand side
B) Right-hand side

To turn on the seat heater, push the “LOW” (“LO”) or “HIGH” (“HI”) position on the switch, as desired, depending on the temperature.

Selecting the “HIGH” (“HI”) position will cause the seat to heat up quicker.

To turn off the seat heater, lightly press the opposite side of the current position.

The indicator located on the switch illuminates when the seat heater is in operation. When the vehicle’s interior is warmed enough or before you leave the vehicle, be sure to turn the switch off.

Rear seats



WARNING

Seatbelts provide maximum restraint when the occupant sits well back and upright in the seat. Do not put cushions or any other materials between occupants and seatbacks or seat cushions. If you do so, the risk of sliding under the lap belt and of the lap belt sliding up over the abdomen will increase, and both can result in serious internal injury or death.

■ Head restraint adjustment

Both the rear window side seats and the rear center seat are equipped with head restraints.

⚠ WARNING

- Never drive the vehicle with the head restraints removed because they are designed to reduce the risk of serious neck injury in the event that the vehicle is struck from the rear. Therefore, when you have removed the head restraints, you must reinstall all head restraints to protect vehicle occupants.
- All occupants, including the driver, should not operate a vehicle or sit in a vehicle's seat until the head restraints are placed in their proper positions in order to minimize the risk of neck injury in the event of a crash.

▼ Rear windows side seating position

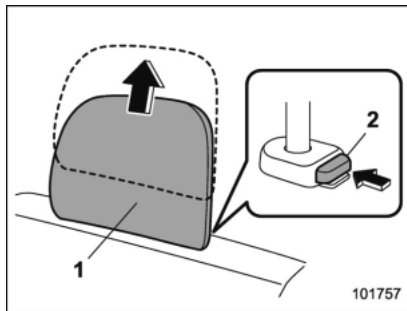

- 1) Head restraint
- 2) Release button

To remove:

While pressing the release button, pull out the head restraint.

To install:

Install the head restraint into the holes that are located on the top of the seatback until the head restraint locks. Press and hold the release button to lower the head restraint.

After installing the head restraint, make sure it is securely locked.

▼ Rear center seating position

⚠ CAUTION

The head restraint is not intended to be used in the retracted position. Before sitting on the seat, raise the head restraint to the extended position.

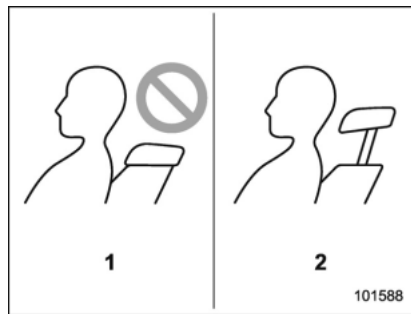

- 1) Incorrect (retracted position)
- 2) Correct (extended position)

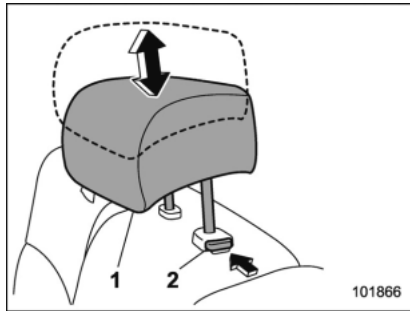

- 1) Head restraint
- 2) Release button

To raise:

Pull the head restraint up.

To lower:

Push the head restraint down while pressing the release button on the top of the seatback.

To remove:

While pressing the release button, pull out the head restraint.

To install:

Install the head restraint into the holes that are located on the top of the seatback until the head restraint locks. Press and hold the release button to lower the head restraint.

When the rear-center seating position is occupied, raise the head restraint to the extended position. When the rear center seating position is not occupied, lower the head restraint to improve rearward visibility.

■ Folding down the rear seat-back

WARNING

- When you fold down the seat-back, check that there are no passengers or objects on the rear seat. Not doing so creates a risk of injury or property damage if the seatback suddenly folds down.
- Never allow passengers to ride on the folded rear seatback or in the trunk. Doing so may result in serious injury or death.
- Secure all objects and especially long items properly to prevent them from being thrown around inside the vehicle and causing serious injury during a sudden stop, a sudden steering maneuver or a rapid acceleration.
- When you return the seatback to its original position, shake the

seatback to confirm that it is securely fixed in place. If the seatback is not securely fixed in place, the seatback may suddenly fold down in the event of sudden braking, or objects may move out from the trunk, which could cause serious injury or death.

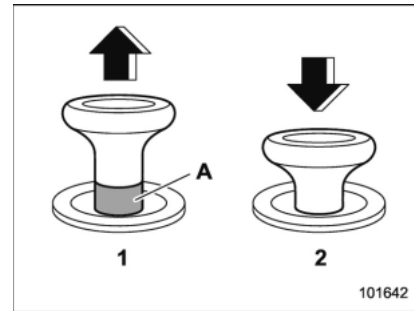
**Lock release knob**

- 1) Unlocked
- 2) Locked
- A) Unlocking marker in red

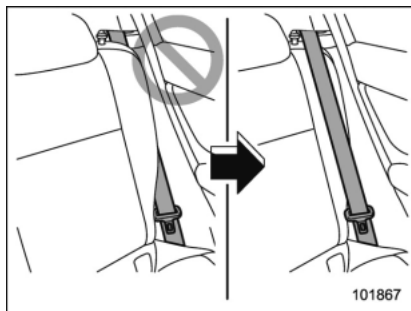

101867

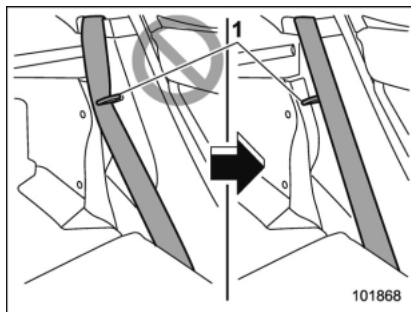

101868

1) Securing hook



WARNING

When the seatback is returned to its original position, observe the follow-

ing precautions. Failure to do so may lead to serious injury or an accident because the operation efficiency of the seatbelt is inhibited.

- The seatbelt should not be caught in the seatback and it should be fully visible.
- The seatbelt should not pass behind the securing hook for the seatback.



CAUTION

Do not hang luggage etc. on the securing hook. The possibility exists that the seatback may not be able to be fixed firmly in place. This could lead to unexpected accidents.

1. Lower the head restraint of the rear center seating position.

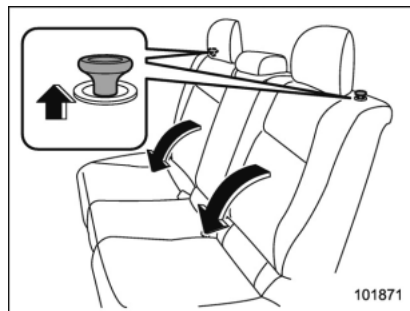

101871

Release knob

2. Unlock the seatback by pulling the lock release knob then fold the seatback down.

To return the seatback to its original position, raise the seatback until it locks into place and make sure that the unlocking marker on the lock release knob is no longer visible.

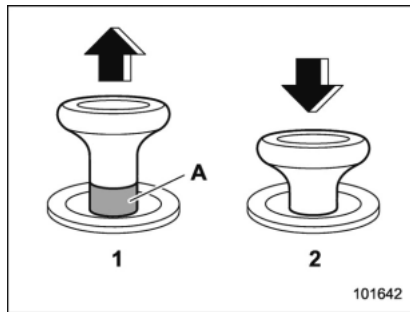

Lock release knob

- 1) Unlocked
 - 2) Locked
- A) Unlocking marker in red

⚠ WARNING

After returning the seatback to its original position, confirm that the unlocking marker of the lock release knob is no longer visible. Failure to do so could lead to serious injury or death in the event of an accident. When you return the seatback to its original position, shake the seatback to confirm that it is securely fixed in place.

Seatbelts

■ Seatbelt safety tips

⚠ WARNING

- All persons in the vehicle should fasten their seatbelts **BEFORE** the vehicle starts to move. Otherwise, the possibility of serious injury becomes greater in the event of a sudden stop or accident.
- All belts should fit snugly in order to provide full restraint. Loose fitting belts are not as effective in preventing or reducing injury.
- Each seatbelt is designed to support only one person. Never use a single belt for two or more persons – even children. Otherwise, in an accident, serious injury or death could result.
- Replace all seatbelt assemblies including retractors and attaching hardware worn by occupants of a vehicle that has been in a serious accident. The entire assembly should be replaced even if damage is not obvious.
- Put children aged 12 and under in

the rear seat properly restrained at all times. The SRS airbag deploys with considerable speed and force and can injure or even kill children, especially if they are 12 years of age and under and are not restrained or improperly restrained. Because children are lighter and weaker than adults, their risk of being injured from deployment is greater. For that reason, we strongly recommend that ALL children (including those in child seats and those that have outgrown child restraint devices) sit in the REAR seat properly restrained at all times in a child restraint device or in a seatbelt, whichever is appropriate for the child's height and weight.

Secure ALL types of child restraint devices (including forward facing child seats) in the REAR seats at all times.

NEVER INSTALL A REARWARD FACING CHILD SEAT IN THE FRONT SEAT. DOING SO RISKS SERIOUS INJURY OR DEATH TO THE CHILD BY PLACING THE CHILD'S HEAD TOO CLOSE TO THE SRS AIRBAG.

According to accident statistics, children are safer when properly restrained in the rear seating positions than in the front seating positions. For instructions and precautions concerning the child restraint system, refer to “Child restraint systems” 1-20.

▼ **Infants or small children**

Use a child restraint system that is suitable for your vehicle. Refer to “Child restraint systems” 1-20.

▼ **Children**

If a child is too big for a child restraint system, the child should sit in the rear seat and be restrained using the seatbelts. According to accident statistics, children are safer when properly restrained in the rear seating positions than in the front seating positions. Never allow a child to stand up or kneel on the seat.

If the shoulder portion of the belt crosses the face or neck, move the child closer to the belt buckle to help provide a good shoulder belt fit. Care must be taken to securely place the lap belt as low as possible on the hips and not on the child's waist. If the shoulder portion of the belt cannot be properly positioned, a child restraint system should be used. Never

place the shoulder belt under the child's arm or behind the child's back.

▼ **Expectant mothers**

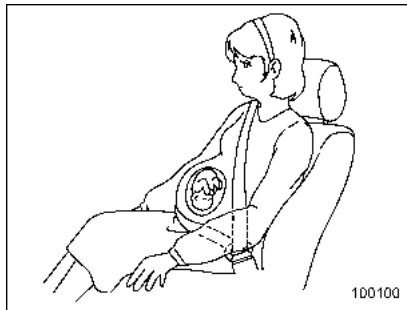

Expectant mothers also need to use the seatbelts. They should consult their doctor for specific recommendations. The lap belt should be worn securely and as low as possible over the hips, not over the waist.

■ **Emergency Locking Retractor (ELR)**

The driver's seatbelt has an Emergency Locking Retractor (ELR).

The emergency locking retractor allows normal body movement but the retractor locks automatically during a sudden stop, impact or if you pull the belt very quickly out of the retractor.

■ **Automatic/Emergency Locking Retractor (A/ELR)**

Each passenger's seatbelt has an Automatic/Emergency Locking Retractor (A/ELR). The Automatic/Emergency Locking Retractor normally functions as an Emergency Locking Retractor (ELR). The A/ELR has an additional locking mode “Automatic Locking Retractor (ALR) mode” intended to secure a child restraint system. When the seatbelt is once drawn out completely and is then retracted even slightly, the retractor locks the seatbelt in that position and the seatbelt cannot be extended. As the belt is rewinding, clicks will be heard which indicate the retractor functions as an ALR. When the seatbelt is retracted fully, the ALR mode is released.

When securing a child restraint system on the rear seats by the use of the seatbelt, the seatbelt must be changed over to the Automatic Locking Retractor (ALR) mode.

When the child restraint system is removed, make sure that the seatbelt retracts fully and the retractor returned to the Emergency Locking Retractor (ELR) mode.

For instructions on how to convert the retractor to the ALR mode and restore it to the ELR mode, refer to “Installing child restraint systems with A/ELR seatbelt”

☞ 1-23.

■ Seatbelt warning light and chime



Refer to “Seatbelt warning light and chime” ☞ 3-13.

■ Fastening the seatbelt

⚠ WARNING

- Never use a belt that is twisted or reversed. In an accident, this can increase the risk or severity of injury.
- Keep the lap belt as low as possible on your hips. In a collision, this spreads the force of the lap belt over stronger hip bones instead of across the weaker abdomen.
- Seatbelts provide maximum restraint when the occupant sits well back and upright in the seat. To reduce the risk of sliding under the seatbelt in a collision, the front seatbacks should be always used in the upright position while the vehicle is running. If the front seatbacks are not used in the upright position in a

collision, the risk of sliding under the lap belt and of the lap belt sliding up over the abdomen will increase, and both can result in serious internal injury or death.

- Do not put cushions or any other materials between occupants and seatbacks or seat cushions. If you do so, the risk of sliding under the lap belt and of the lap belt sliding up over the abdomen will increase, and both can result in serious internal injury or death.

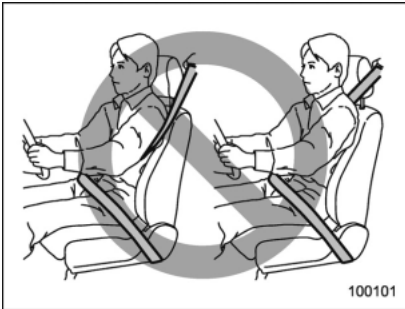

⚠ WARNING

Never place the shoulder belt under

the arm or behind the back. If an accident occurs, this can increase the risk or severity of injury.

⚠ CAUTION

Metallic parts of the seatbelt can become very hot in a vehicle that has been closed up in sunny weather; they could burn an occupant. Do not touch such hot parts until they cool.

▼ Front seatbelts

1. Adjust the seat position according to the following procedure.

Driver's seat: Adjust the seatback to the upright position. Move the seat as far from the steering wheel as practical while still maintaining full vehicle control.

Front passenger's seat: Adjust the seatback to the upright position. Move the seat as far back as possible.

2. Sit well back in the seat.

3. Pick up the tongue plate and pull the belt out slowly. Do not let it get twisted. If the belt stops before reaching the buckle, return the belt slightly and pull it out more slowly. If the belt still cannot be unlocked, let the belt retract slightly after giving it a

strong pull, then pull it out slowly again.

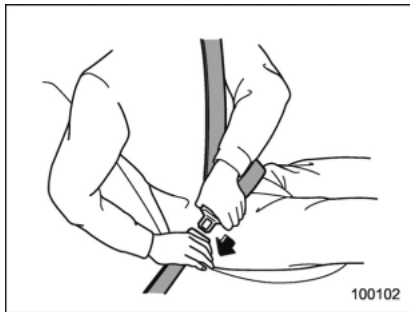

4. Insert the tongue plate into the buckle until you hear a click.

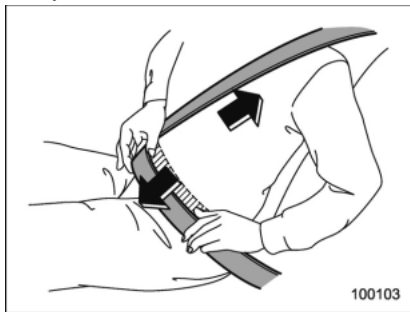

5. To make the lap part tight, pull up on the shoulder belt.

6. Place the lap belt as low as possible

on your hips, not on your waist.

▽ **Adjusting the front seat shoulder belt anchor height**

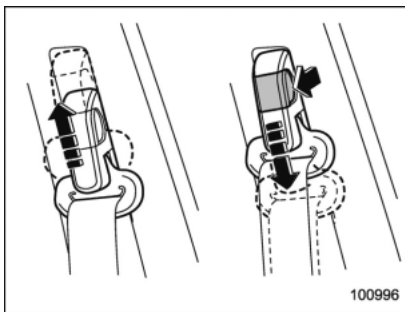

The shoulder belt anchor height should be adjusted to the position best suited for the driver/front passenger. Always adjust the anchor height so that the shoulder belt passes over the middle of the shoulder without touching the neck.

To raise:

Slide the anchor up.

To lower:

Pull the release knob and slide the anchor down.

Pull down on the anchor to make sure that it is locked in place.

WARNING

When wearing the seatbelts, make sure the shoulder portion of the webbing does not pass over your neck. If it does, adjust the seatbelt anchor to a lower position. Placing the shoulder belt over the neck may result in neck injury during sudden braking or in a collision.

▽ **Unfastening the seatbelt**

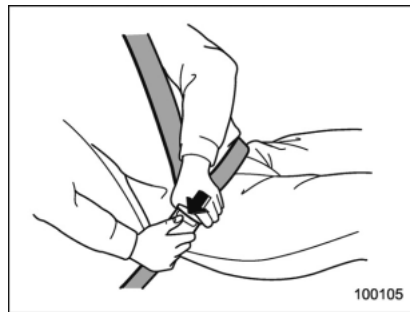

Push the button on the buckle.

Before closing the door, make sure that the belts are retracted properly to avoid catching the belt webbing in the door.

▼ Rear seatbelts

1. Sit well back in the seat.
2. Pick up the tongue plate and pull the belt out slowly. Do not let it get twisted. If the belt stops before reaching the buckle, return the belt slightly and pull it out more slowly. If the belt still cannot be unlocked, let the belt retract slightly after giving a strong pull on it, then pull it out slowly again.

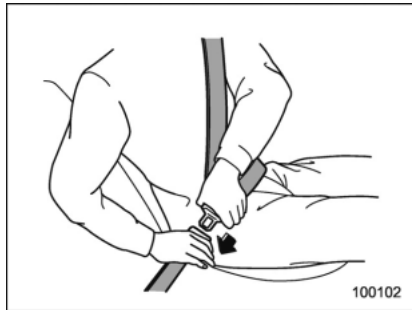

3. Insert the tongue plate into the buckle until you hear a click.

NOTE

The center seatbelt buckle is marked as “CENTER”.

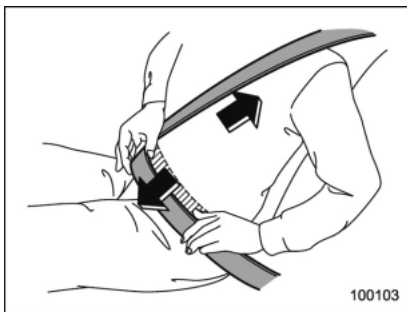

4. To make the lap part tight, pull up on the shoulder belt.
5. Place the lap belt as low as possible on your hips, not on your waist.

▽ Unfastening the seatbelt

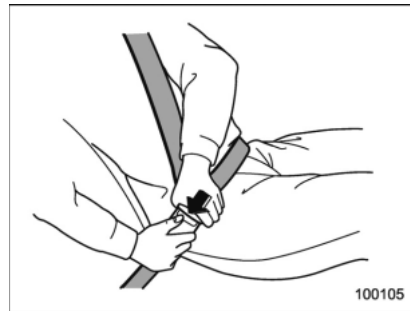

Push the button on the buckle.

Before closing the door, make sure that the belts are retracted properly to avoid catching the belt webbing in the door.

■ Seatbelt maintenance

To clean the seatbelts, use lukewarm water with mild soap. Do not use the seatbelts until they are dry. Never bleach or dye the belts because this could seriously affect their strength.

Inspect the seatbelts and attachments including the webbing and all hardware periodically for cracks, cuts, gashes, tears, damage, loose bolts or worn areas. Replace the seatbelts even if only minor damage is found.

 CAUTION

- Keep the belts free of polishes, oils, chemicals and particularly battery acid.
- Never attempt to make modifications or changes that will prevent the seatbelt from operating properly.

Front seatbelt pretensioners

The driver's and front passenger's seatbelts have a seatbelt pretensioner. The seatbelt pretensioners are designed to be activated in the event of an accident involving moderate to severe frontal and side collisions.

The pretensioner sensor also serves as follows.

- SRS frontal airbag sensor
- Side impact sensor (front door impact sensor)

■ Seatbelt with shoulder belt pretensioner

NOTE

This section is applicable to the driver's side seatbelt.

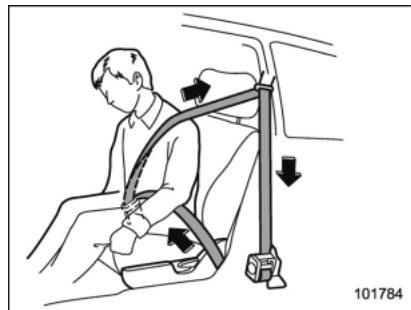

If the sensor detects a certain predetermined amount of force during frontal or side collisions, the front seatbelt is quickly drawn back in by the retractor to take up the slack so that the belt more effectively restrains the driver.

When a seatbelt pretensioner is activated, an operating noise will be heard and a small amount of smoke will be released. These occurrences are normal and not harmful. This smoke does not indicate a fire in the vehicle.

Once the seatbelt pretensioner has been activated, the seatbelt retractor remains locked. Consequently, the seatbelt cannot be pulled out and retracted and therefore must be replaced.

NOTE

- Seatbelt pretensioners are not designed to activate in minor impacts or in rear impacts.
 - In cases of frontal collisions, the following components will operate simultaneously.
 - Seatbelt pretensioner for driver
 - Seatbelt pretensioner for front passenger
 - SRS frontal airbag for driver
 - SRS frontal airbag for front passenger*
 - SRS curtain airbags (both sides) (if an offset frontal collision occurs)
- *: This does not operate if the occupant detection system deactivates airbag operation. For details, refer to “Front passenger’s SRS frontal airbag” 1-39.
- In cases of side collisions, the following components will operate simultaneously.
 - SRS curtain airbag (impacted side)
 - SRS side airbag (impacted side) (when both the satellite safing sensor and any of the center pillar impact sensors/front door impact sensors sense an impact force)
 - Seatbelt pretensioner for driver (when both the satellite safing sen-

sor and the driver’s side front door impact sensor sense an impact force)

- Seatbelt pretensioner for front passenger (shoulder belt pretensioner only) (when both the satellite safing sensor and the front passenger’s side front door impact sensor sense an impact force)
- Pretensioners are designed to function on a one-time-only basis. In the event that a pretensioner is activated, both the driver’s and front passenger’s seatbelt retractor assemblies should be replaced only by an authorized SUBARU dealer. When replacing seatbelt retractor assemblies, use only genuine SUBARU parts.
- If either front seatbelt does not retract or cannot be pulled out due to a malfunction or activation of the pretensioner, contact your SUBARU dealer as soon as possible.
- If the front seatbelt retractor assembly or surrounding area has been damaged, contact your SUBARU dealer as soon as possible.
- When you sell your vehicle, we urge you to explain to the buyer that it has seatbelt pretensioners by alerting the buyer to the contents of this section.

**WARNING**

- To obtain maximum protection, the occupants should sit in an upright position with their seatbelts properly fastened. Refer to “Seatbelts” 1-11.
- Do not modify, remove or strike the front seatbelt retractor assemblies or surrounding area. This could result in accidental activation of the seatbelt pretensioners or could make the system inoperative, possibly resulting in serious injury. Seatbelt pretensioners have no user-serviceable parts. For required servicing of front seatbelt retractors equipped with seatbelt pretensioners, consult your SUBARU dealer.
- When discarding front seatbelt retractor assemblies or scrapping the entire vehicle due to collision damage or for other reasons, consult your SUBARU dealer.

■ Seatbelt with shoulder belt and lap belt pretensioners

NOTE

This section is applicable to the front passenger's side seatbelt.

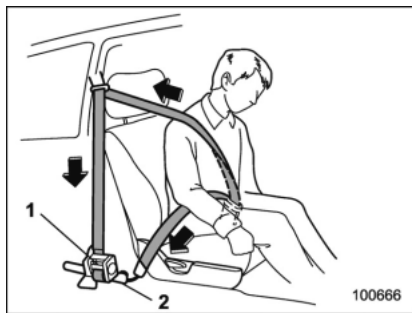

- 1) Seatbelt retractor assembly (shoulder belt pretensioner)
- 2) Lap belt pretensioner

On the front passenger's side, the shoulder belt pretensioner is supplemented by a lap belt pretensioner, which is located at the base of the center pillar. Like the shoulder belt pretensioner, the lap belt pretensioner instantaneously pulls in the belt to eliminate slack if a certain level of frontal or side collision force is detected. As a result, the seatbelt restrains the front seat occupant more effectively.

When a seatbelt pretensioner is activated, an operating noise will be heard and a small amount of smoke will be released. These occurrences are normal and not harmful. This smoke does not indicate a fire in the vehicle.

Once the seatbelt pretensioner has been activated, the seatbelt pretensioner remains locked. Consequently, the seatbelt cannot be pulled out and retracted and therefore must be replaced.

NOTE

- Seatbelt pretensioners are not designed to activate in minor impacts or in rear impacts.
 - In cases of frontal collisions, the following components will operate simultaneously.
 - Seatbelt pretensioner for driver
 - Seatbelt pretensioners for front passenger (shoulder belt pretensioner only)
 - SRS frontal airbag for driver
 - SRS frontal airbag for front passenger*
 - SRS curtain airbags (both sides) (if an offset frontal collision occurs)
- *: This does not operate if the occupant detection system deactivates airbag operation. For details, refer to "Front

passenger's SRS frontal airbag" 1-39.

- In cases of side collisions, the following components will operate simultaneously.
 - SRS curtain airbag (impacted side)
 - SRS side airbag (impacted side) (when both the satellite safing sensor and any of the center pillar impact sensors/front door impact sensors sense an impact force)
 - Seatbelt pretensioner for driver (when both the satellite safing sensor and the driver's side front door impact sensor sense an impact force)
 - Seatbelt pretensioner for front passenger (shoulder belt pretensioner only) (when both the satellite safing sensor and the front passenger's side front door impact sensor sense an impact force)
- Pretensioners are designed to function on a one-time-only basis. In the event that a pretensioner is activated, both the driver's and front passenger's seatbelt retractor assemblies should be replaced only by an authorized SUBARU dealer. When replacing seatbelt retractor assemblies, use only genuine SUBARU parts.
- If either front seatbelt does not

retract or cannot be pulled out due to a malfunction or activation of the pretensioner, contact your SUBARU dealer as soon as possible.

- If the front seatbelt retractor assembly or surrounding area has been damaged, contact your SUBARU dealer as soon as possible.
- When you sell your vehicle, we urge you to explain to the buyer that it has seatbelt pretensioners by alerting the buyer to the contents of this section.

 **WARNING**

- To obtain maximum protection, the occupants should sit in an upright position with their seatbelts properly fastened. Refer to "Seatbelts" ¶1-11.
- Do not modify, remove or strike the front seatbelt retractor assemblies or surrounding area. This could result in accidental activation of the seatbelt pretensioners or could make the system inoperative, possibly resulting in serious injury. Seatbelt pretensioners have no user-serviceable parts. For required servicing of front seatbelt retractors equipped with seatbelt pre-

sioners, consult your SUBARU dealer.

- When discarding front seatbelt retractor assemblies or scrapping the entire vehicle due to collision damage or for other reasons, consult your SUBARU dealer.

■ **System monitors**

A diagnostic system continually monitors the readiness of the seatbelt pretensioner while the vehicle is being driven. The seatbelt pretensioners share the control module with the SRS airbag system. Therefore, if any malfunction occurs in a seatbelt pretensioner, the SRS airbag system warning light will illuminate. For details, refer to "SRS airbag system monitors" ¶1-56.

■ **System servicing**

 **WARNING**

- When discarding a seatbelt retractor assembly or scrapping the entire vehicle damaged by a collision, consult your SUBARU dealer.

- Tampering with or disconnecting the system's wiring could result in accidental activation of the seatbelt pretensioner and/or SRS airbag or could make the system inoperative, which may result in serious injury. Do not use electrical test equipment on any circuit related to the seatbelt pretensioner and SRS airbag systems. For required servicing of the seatbelt pretensioner, consult your nearest SUBARU dealer.

 **CAUTION**

The sensors and SRS airbag control modules are located in the following locations.

- Front sub sensors: on both the right and left side at the front of the vehicle
- Front door impact sensors: on both front doors
- Satellite safing sensor: under the rear center seat
- SRS airbag control module (including the impact sensors): under the center of the instrument panel

If you need service or repair in those areas or near the front seatbelt, have the work performed by your authorized SUBARU dealer.

NOTE

If the front or side part of the vehicle is damaged in an accident to the extent that the seatbelt pretensioner does not operate, contact your SUBARU dealer as soon as possible.

■ Precautions against vehicle modification

Always consult your SUBARU dealer if you want to install any accessory parts to your vehicle.



CAUTION

Do not perform any of the following modifications. Such modifications can interfere with proper operation of the seatbelt pretensioners.

- Attachment of any equipment other than genuine SUBARU accessory parts to the front end.
- Modification of the suspension system or front end structure.
- Installation of a tire of different size and construction from the tires specified on the vehicle placard attached to the driver's door pillar or specified for individual vehicle models in this Owner's Manual.

Child restraint systems



Infants and small children should always be placed in an infant or child restraint system in the rear seat while riding in the vehicle. You should use an infant or child restraint system that meets Federal Motor Vehicle Safety Standards or Canada Motor Vehicle Safety Standards, is compatible with your vehicle and is appropriate for the child's age and size. All child restraint systems are designed to be secured in vehicle seats by lap belts or the lap belt portion of a lap/shoulder belt (except those described in "Installation of child restraint systems by use of lower and tether anchorages (LATCH)" ¶1-28).

Children could be endangered in an accident if their child restraints are not

properly secured in the vehicle. When installing the child restraint system, carefully follow the manufacturer's instructions.

According to accident statistics, children are safer when properly restrained in the rear seating positions than in the front seating positions.

All U.S. states and Canadian provinces require that infants and small children be restrained in an approved child restraint system at all times while the vehicle is moving.

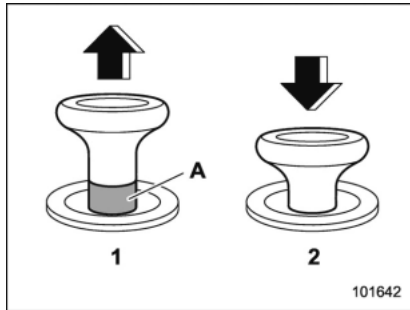

Lock release knob

- 1) Unlocked
 - 2) Locked
- A) Unlocking marker in red

⚠ WARNING

Before installing a child restraint system, be sure to confirm that the seatback is securely locked into place. Otherwise, in an accident, serious injury or death could result.



⚠ WARNING

Never let a passenger hold a child on his or her lap or in his or her arms while the vehicle is moving. The passenger cannot protect the child from injury in a collision, because the child will be caught between the passenger and objects inside the vehicle.

Additionally, holding a child in your lap or arms in the front seat exposes that child to another serious danger. Since the SRS airbag deploys with considerable speed and force, the child could be injured or even killed.

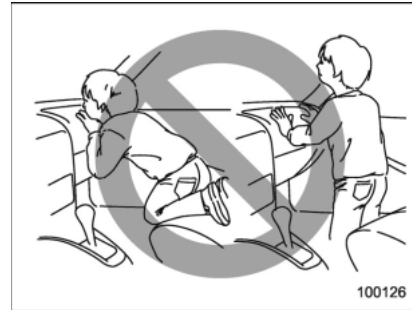

⚠ WARNING

Children should be properly restrained at all times. Never allow a child to stand up, or to kneel on any seat. Unrestrained children will be thrown forward during sudden stop or in an accident and can be injured seriously.

Additionally, children standing up or kneeling on or in front of the front

seat are exposed another serious danger. Since the SRS airbag deploys with considerable speed and force, the child could be injured or even killed.

■ Where to place a child restraint system

The following are SUBARU's recommendations on where to place a child restraint system in your vehicle.

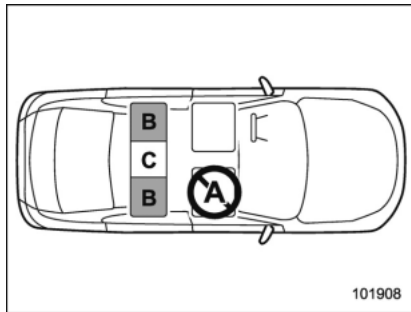

A: Front passenger's seat

You should not install a child restraint system (including a booster seat) due to the hazard to children posed by the passenger's airbag.

B: Rear seat, window-side seating positions

Recommended positions for all types of child restraint systems.

In these positions, Automatic/Emergency Locking Retractor (A/ELR) seatbelts and lower anchorages (bars) are provided for installing a child restraint system.

Some types of child restraints might not be able to be secured firmly due to projection of the seat cushion.

In this seating position, you should use only a child restraint system that has a bottom base that fits snugly against the contours of the seat cushion and can be securely retained using the seatbelt.

C: Rear seat, center seating position

The A/ELR seatbelt and an upper anchorage (tether anchorage, if equipped) are provided in this position.

Some types of child restraints might not be able to be secured firmly due to projection of the seat cushion.

In this seating position, you should use only a child restraint system that has a bottom base that fits snugly against the contours of the seat cushion and can be securely retained using the seatbelt.

When you install a child restraint system in the rear seat's center seating position, remove the center head restraint.

Lower anchorages (bars) for window-side seating positions may be used for a seat in the center seating position if a child restraint system manufacturer's instructions permit and specify using anchors as far apart as those in this vehicle.

If a child restraint system is not correctly fixed in place (for example, if a child restraint system can be moved more than 1 inch (2.5 cm) from side to side), you should install the child restraint system in a rear seat, window-side seating position.



WARNING

- Put children aged 12 and under in the rear seat properly restrained at all times. The SRS airbag deploys with considerable speed and force and can injure or even kill children, especially if they are 12 years of age and under and are not restrained or improperly restrained. Because children are lighter and weaker than adults, their risk of being injured from deployment is greater.

For that reason, be sure to secure ALL types of child restraint devices (including forward facing child seats) in the REAR seats at all times. You should choose a

restraint device which is appropriate for the child's age, height and weight. According to accident statistics, children are safer when properly restrained in the rear seating positions than in the front seating positions.

- Do not use lower anchorages (bars) for a seat in the center seating position unless a child restraint system manufacturer's instructions permit and specify using anchors spaced as far apart as those in this vehicle.

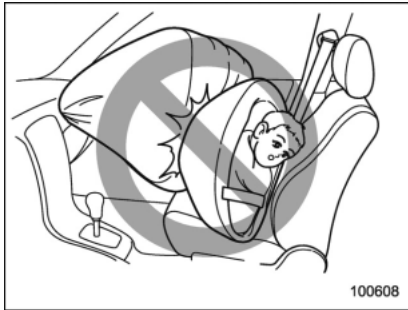

WARNING

SINCE YOUR VEHICLE IS EQUIPPED WITH A PASSENGER'S SRS AIRBAG, NEVER INSTALL A REARWARD FACING CHILD SAFETY SEAT IN THE FRONT PASSENGER'S SEAT. DOING SO RISKS SERIOUS INJURY OR DEATH TO THE CHILD BY PLACING THE CHILD'S HEAD TOO CLOSE TO THE SRS AIRBAG.

■ **Choosing a child restraint system**

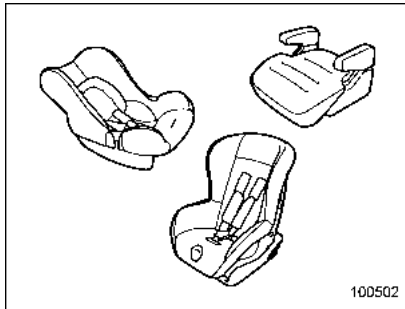

Choose a child restraint system that is appropriate for the child's age and size (weight and height) in order to provide the

child with proper protection. The child restraint system should meet all applicable requirements of Federal Motor Vehicle Safety Standards for the United States or of Canada Motor Vehicle Safety Standards for Canada. It can be identified by looking for the label on the child restraint system or the manufacturer's statement of compliance in the document attached to the system.

Also it is important for you to make sure that the child restraint system is compatible with the vehicle in which it will be used.

■ **Installing child restraint systems with A/ELR seatbelt**

WARNING

- Child restraint systems and seatbelts can become hot in a vehicle that has been closed up in sunny weather; they could burn a small child. Check the child restraint system before you place a child in it.
- Do not leave an unsecured child restraint system in your vehicle. Unsecured child restraint systems can be thrown around inside of the vehicle in a sudden

stop, turn or accident; they can strike and injure vehicle occupants as well as result in serious injuries or death to the child.

CAUTION

When you install a child restraint system, follow the manufacturer's instructions supplied with it. After installing the child restraint system, check to ensure that it is held securely in position. If it is not held tight and secure, the danger of your child suffering personal injury in the event of an accident may be increased.

▼ **Installing a rearward facing child restraint**

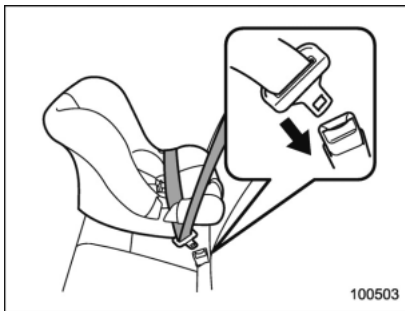

1. Shake the seatback to confirm that it is securely locked into place.
 - It is possible to check whether the seatback is locked visually. If the seatback is locked into place, the red colored unlocking marker which is attached to the bottom of the lock release knob is invisible. For details, refer to "Folding down the rear seatback" 1-9.
2. Place the child restraint system in the rear seating position.
3. Run the lap and shoulder belt through or around the child restraint system following the instructions provided by its manufacturer.

4. Insert the tongue plate into the buckle until you hear a click.

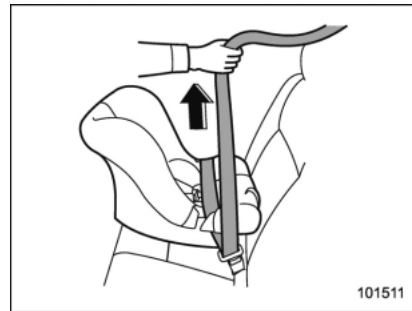

5. Take up the slack in the lap belt.
6. Pull out the seatbelt fully from the retractor to change the retractor over from the Emergency Locking Retractor (ELR) to the Automatic Locking Retractor (ALR) function. Then, allow the belt to rewind into the retractor. As the belt is rewinding, clicks will be heard which indicate the retractor functions as ALR.

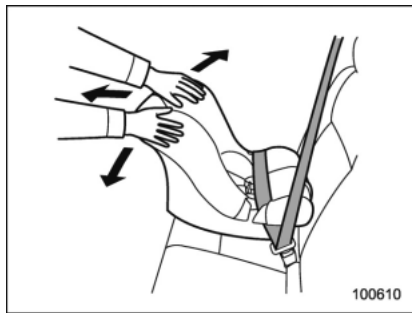

7. Push and pull the child restraint system forward and from side to side to check if it is firmly secured. Sometimes a child restraint can be more firmly secured by pushing it down into the seat cushion and then tightening the seatbelt.

8. Pull at the shoulder portion of the belt to confirm that it cannot be pulled out (ALR properly functioning).

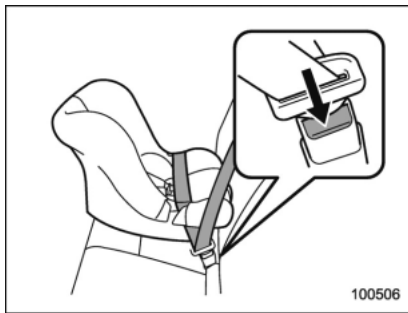

9. To remove the child restraint system, press the release button on the seatbelt buckle and allow the belt to retract completely. The belt will return to the ELR mode.

WARNING

NEVER INSTALL A REARWARD FACING CHILD SEAT IN THE FRONT PASSENGER'S SEAT. DOING SO RISKS SERIOUS INJURY OR DEATH TO THE CHILD BY PLACING THE CHILD'S HEAD TOO CLOSE TO THE SRS AIRBAG.

NOTE

When the child restraint system is no longer in use, remove it and restore the ELR function of the retractor. That function is restored by allowing the seatbelt to retract fully.

▼ **Installing forward facing child restraint**

1. Shake the seatback to confirm that it is securely locked into place.

– It is possible to check whether the seatback is locked visually. If the seatback is locked into place, the red colored unlocking marker which is attached to the bottom of the lock release knob is invisible. For details, refer to "Folding down the rear seatback" 1-9.

2. Remove the head restraint of the rear seating position where the child restraint system is to be installed. For details, refer to "Head restraint adjustment" 1-8.

CAUTION

Store the head restraint that has been removed in the cargo area. Avoid placing the head restraint in the passenger compartment to prevent it from being thrown around in the passenger compartment in a

sudden stop or a sharp turn.

3. Place the child restraint system in the rear seating position.

⚠ WARNING

When you intend to install a child restraint system on the rear center seating position, if the child restraint system does not fit snugly against the contours of the rear center seat cushion, install the child restraint system on the window-side seating position to be safe. For details, refer to “Where to place a child restraint system” Ⓞ 1-22.

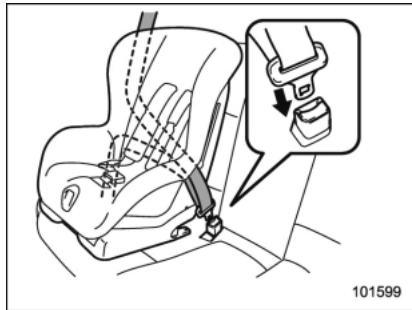

4. Run the lap and shoulder belt through

or around the child restraint system following the instructions provided by its manufacturer.

5. Insert the tongue plate into the buckle until you hear a click.

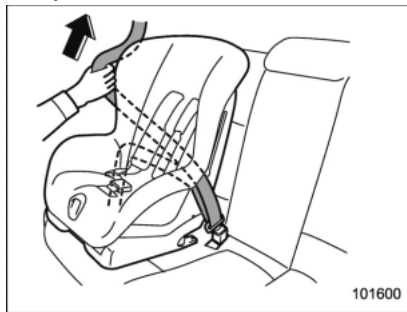

6. Take up the slack in the lap belt.
7. Pull out the seatbelt fully from the retractor to change the retractor over from the Emergency Locking Retractor (ELR) to the Automatic Locking Retractor (ALR) function. Then, allow the belt to rewind into the retractor. As the belt is rewinding, clicks will be heard which indicate the retractor functions as ALR.

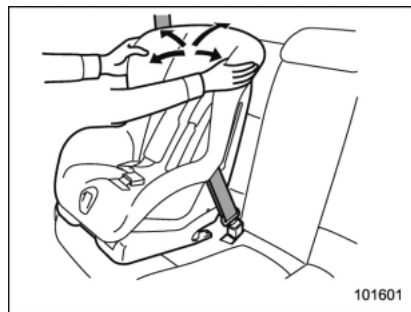

8. Before having a child sit in the child restraint system, try to move it back and forth and right and left to check if it is firmly secured. Sometimes a child restraint can be more firmly secured by pushing it down into the seat cushion and then tightening the seatbelt.
9. Pull at the shoulder portion of the belt to confirm that it cannot be pulled out (ALR properly functioning).
10. Latch the top tether hook onto the tether anchorage that is located behind the rear seat and tighten the top tether firmly. For additional instructions, refer to “Top tether anchorages” Ⓞ 1-31.

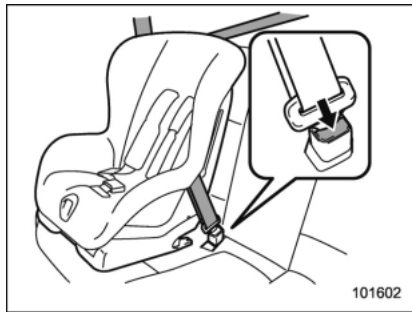

11. To remove the child restraint system, press the release button on the seatbelt buckle and allow the belt to retract completely. The belt will return to the ELR mode.

NOTE

When the child restraint system is no longer in use, remove it and restore the ELR function of the retractor. That function is restored by allowing the seatbelt to retract fully.

■ Installing a booster seat

WARNING

- Child restraint systems and seatbelts can become hot in a vehicle that has been closed up in sunny weather; they could burn a small child. Check the child restraint system before you place a child in it.
- Do not leave an unsecured child restraint system in your vehicle. Unsecured child restraint systems can be thrown around inside of the vehicle in a sudden stop, turn or accident; they can strike and injure vehicle occupants as well as result in serious injuries or death to the child.

CAUTION

When you install a child restraint system, follow the manufacturer's instructions supplied with it. After installing the child restraint system, check to ensure that it is held securely in position. If it is not held tight and secure, the danger of your child suffering personal injury in the event of an accident may be in-

creased.



1. Place the booster seat in the rear seating position and sit the child on it. The child should sit well back on the booster seat.
2. Run the lap and shoulder belt through or around the booster seat and the child following the instructions provided by its manufacturer.
3. Insert the tongue plate into the buckle until you hear a click. Take care not to twist the seatbelt.

Make sure the shoulder belt is positioned across the center of child's shoulder and that the lap belt is positioned as low as possible on the child's hips.

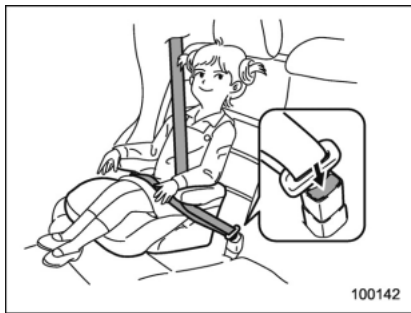

4. To remove the booster seat, press the release button on the seatbelt buckle and allow the belt to retract.



WARNING

- Never use a belt that is twisted or reversed. In an accident, this can increase the risk or severity of injury to the child.
- Never place the shoulder belt under the child's arm or behind the child's back. If an accident occurs, this can increase the risk or severity of injury to the child.
- The seatbelt should fit snugly in order to provide full restraint. Loose fitting belts are not as

effective in preventing or reducing injury.

- Place the lap belt as low as possible on the child's hips. A high-positioned lap belt will increase the risk of sliding under the lap belt and of the lap belt sliding up over the abdomen, and both can result in serious internal injury or death.
- Make sure the shoulder belt is positioned across the center of child's shoulder. Placing the shoulder belt over the neck may result in neck injury during sudden braking or in a collision.

■ Installation of child restraint systems by use of lower and tether anchorages (LATCH)



WARNING

- Child restraint systems and seatbelts can become hot in a vehicle that has been closed up in sunny weather; they could burn a small child. Check the child restraint system before you place a child in it.
- Do not leave an unsecured child

restraint system in your vehicle. Unsecured child restraint systems can be thrown around inside of the vehicle in a sudden stop, turn or accident; they can strike and injure vehicle occupants as well as result in serious injuries or death to the child.



CAUTION

When you install a child restraint system, follow the manufacturer's instructions supplied with it. After installing the child restraint system, check to ensure that it is held securely in position. If it is not held tight and secure, the danger of your child suffering personal injury in the event of an accident may be increased.

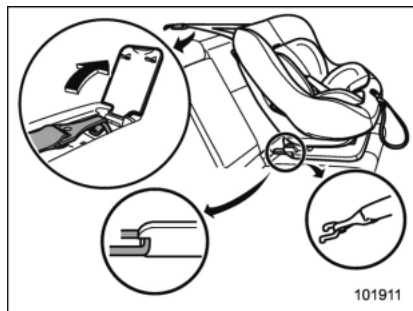

101911

Some types of child restraint systems can be installed on the rear seat of your vehicle without use of the seatbelts. Such child restraint systems are secured to the designated anchorages provided on the vehicle body. The lower and tether anchorages are sometimes referred to as the LATCH system (**L**ower **A**nchors and **T**ethers for **C**hildren).



101210

Your vehicle is equipped with four lower anchorages (bars) and three upper anchorages (tether anchorages) for accommodating such child restraint systems.

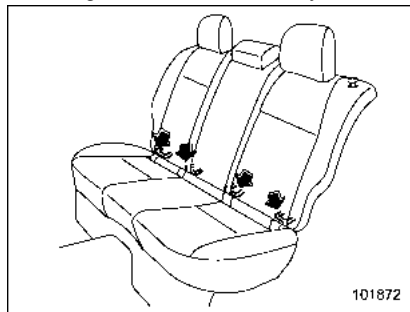

101872

The lower anchorages (bars) are used for installing a child restraint system only on

the rear seat window-side seating positions. For each window-side seating position, two lower anchorages are provided. Each lower anchorage is located behind the cover of the seatback bottom.

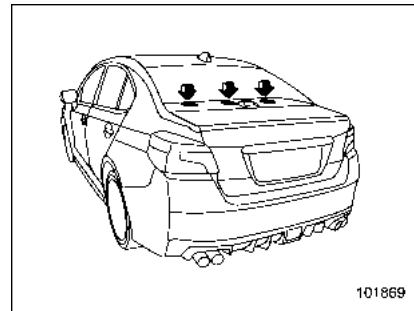

101869

The tether anchorages (upper anchorages) are provided at the locations shown in the above illustration. For details, refer to "Top tether anchorages" 1-31.

To install a child restraint system using lower and tether anchorages, perform the following procedure.

1. Shake the seatback to confirm that it is securely locked into place.
 - It is possible to check whether the seatback is locked visually. If the seatback is locked into place, the red

1-30 Seat, seatbelt and SRS airbags/Child restraint systems

colored unlocking marker which is attached to the bottom of the lock release knob is invisible. For details, refer to "Folding down the rear seatback" 1-9.

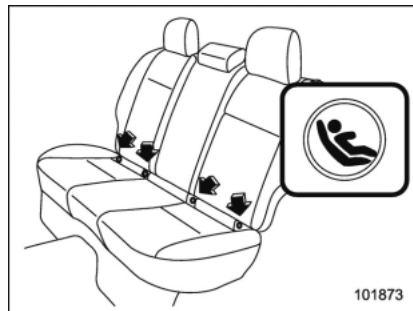

2. You will find marks "Ⓢ" at the bottom of the rear seat seatbacks. These marks indicate the positions of the lower anchorages (bars).

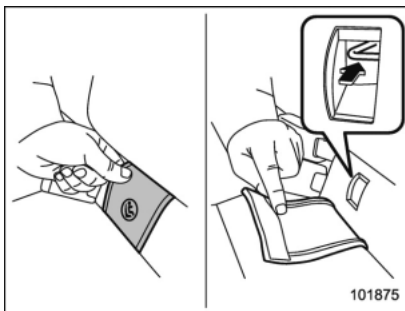

Remove the covers and locate the lower anchorages (bars).

3. Remove the rear seat head restraint. For details, refer to "Head restraint adjustment" 1-8.



CAUTION

Store the head restraint that has been removed in the cargo area. Avoid placing the head restraint in the passenger compartment to prevent it from being thrown around in the passenger compartment in a sudden stop or a sharp turn.

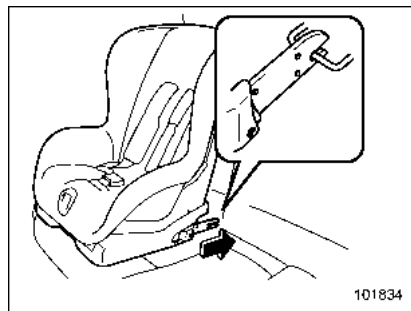

4. While following the instructions supplied by the child restraint system manufacturer, connect the lower hooks onto the lower anchorages located at "Ⓢ" marks on the bottom of the rear seatback. When the hooks are connected, make sure the adjacent seatbelts are not caught.

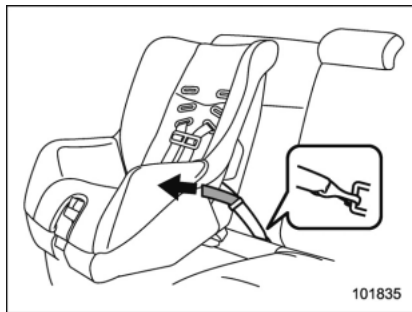

5. [If your child restraint system is of a flexible attachment type (which uses tether belts to connect the child restraint system properly to the lower anchorages)] While pushing the child restraint into the seat cushion, pull both left and right lower tether belts up to secure the child restraint system firmly by taking up the slack in the belt.

6. Latch the top tether hook onto the tether anchorage that is located on the rear shelf and tighten the top tether firmly. For additional instructions, refer to "Top tether anchorages" ¹⁻³¹.

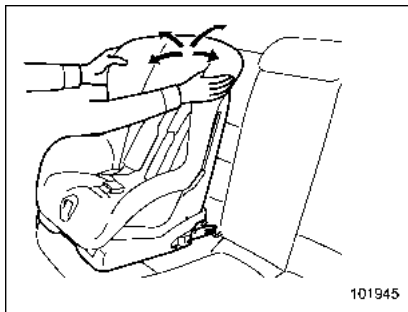

7. Before seating a child in the child restraint system, try to move it back and forth and right and left to verify that it is held securely in position.

8. To remove the child restraint system, follow the reverse procedures of installation.

If you have any question concerning this type of child restraint system, ask your SUBARU dealer.

■ Top tether anchorages

Your vehicle is equipped with three top tether anchorages so that a child restraint system having a top tether can be installed in the rear seat. When installing a child restraint system using top tether, proceed as follows, while observing the instructions by the child restraint system manufacturer.

Since a top tether can provide additional stability by offering another connection between a child restraint system and the vehicle, we recommend that you use a top tether whenever one is required or available.

▼ Anchorage location

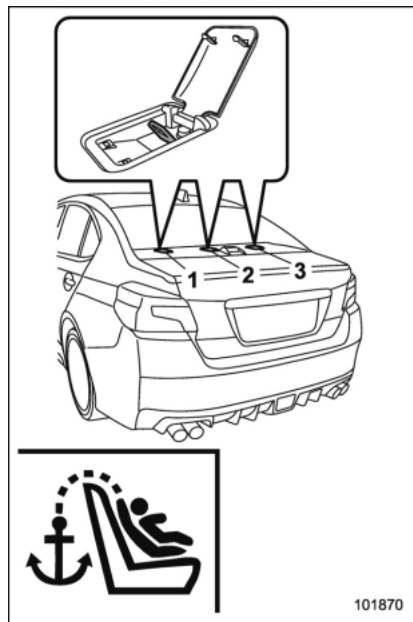

- 1) For left seat
- 2) For center seat
- 3) For right seat

These upper anchorages are installed on the rear shelf behind the rear seat.

▼ To hook the top tether

CAUTION

Remove the head restraint when mounting a child restraint system. Otherwise, it might be possible that the top tether cannot be fastened tightly.

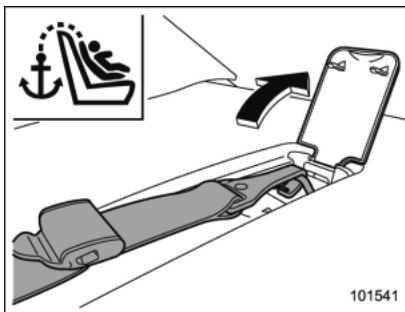

1. Open the cover and attach the top tether hook to the appropriate upper anchorage.
2. Tighten the top tether securely.

Please contact your SUBARU dealer if you have any question regarding the installation of a child restraint system.

***SRS airbag (Supplemental Restraint System airbag)**

*SRS: This stands for supplemental restraint system. This name is used because the airbag system supplements the vehicle's seatbelts.

■ **Models with SRS airbags and lap/shoulder restraints for driver, front passenger, and window-side rear passengers**

Your vehicle is equipped with a supplemental restraint system in addition to a lap/shoulder belt at each front seating position and each rear window-side seating positions. The supplemental restraint system (SRS) consists of seven airbags. The configurations are as follows.

- Driver's and front passenger's **frontal airbags**
- Driver's and front passenger's **side airbags**
- **Curtain airbags** (for driver, front passenger, and window-side rear passengers)
- **Knee airbag** for driver

These SRS airbags are designed only as a supplement to the primary protection provided by the seatbelt.

The system also controls front seatbelt pretensioners. For operation instructions and precautions concerning the seatbelt pretensioner, refer to "Front seatbelt pretensioners" 1-16.

⚠ WARNING

- To obtain maximum protection in the event of an accident, the driver and all passengers in the vehicle should always wear seatbelts when the vehicle is moving. The SRS airbag is designed only to be a supplement to the primary protection provided by the seatbelt. It does not eliminate the need to fasten seatbelts. In combination with the seatbelts, it offers the best combined protection in case of a serious accident. Not wearing a seatbelt increases the chance of severe injury or death in a crash even when the vehicle has the SRS airbag. For instructions and precautions concerning the seatbelt system, refer to "Seatbelts" 1-11.
- Do not sit or lean unnecessarily close to the SRS airbag. Because the SRS airbag deploys with considerable speed – faster than

the blink of an eye – and force to protect in high speed collisions, the force of an airbag can injure an occupant whose body is too close to SRS airbag.

It is also important to wear your seatbelt to help avoid injuries that can result when the SRS airbag contacts an occupant not in proper position such as one thrown forward during pre-accident braking.

Even when properly positioned, there remains a possibility that an occupant may suffer minor injury such as abrasions and bruises to the face or arms because of the SRS airbag deployment force.

- The SRS airbags deploy with considerable speed and force. Occupants who are out of proper position when the SRS airbag deploys could suffer very serious injuries. Because the SRS airbag needs enough space for deployment, the driver should always sit upright and well back in the seat as far from the steering wheel as practical while still maintaining full vehicle control and the front passenger should

move the seat as far back as possible and sit upright and well back in the seat.

- Do not place any objects over or near the SRS airbag cover or between you and the SRS airbag. If the SRS airbag deploys, those objects could interfere with its proper operation and could be propelled inside the vehicle and cause injury.



⚠ WARNING

- Put children aged 12 and under in the rear seat properly restrained at all times. The SRS airbag deploys with considerable speed

and force and can injure or even kill children, especially if they are 12 years of age and under and are not restrained or improperly restrained. Because children are lighter and weaker than adults, their risk of being injured from deployment is greater.

For that reason, we strongly recommend that ALL children (including those in child seats and those that have outgrown child restraint devices) sit in the REAR seat properly restrained at all times in a child restraint device or in a seatbelt, whichever is appropriate for the child's age, height and weight.

Secure ALL types of child restraint devices (including forward facing child seats) in the REAR seats at all times.

According to accident statistics, children are safer when properly restrained in the rear seating positions than in the front seating positions.

For instructions and precautions concerning the child restraint system, refer to "Child restraint systems"  1-20.

- NEVER INSTALL A REARWARD FACING CHILD SEAT IN THE FRONT SEAT. DOING SO RISKS SERIOUS INJURY OR DEATH TO THE CHILD BY PLACING THE CHILD'S HEAD TOO CLOSE TO THE SRS AIRBAG.
- Never allow a child to stand up, or to kneel on the front passenger's seat, or never hold a child on your lap or in your arms. The SRS airbag deploys with considerable force and can injure or even kill the child.



CAUTION

- When the SRS airbag deploys, some smoke will be released. This smoke could cause breathing problems for people with a history of asthma or other breathing trouble. If you or your passengers have breathing problems after SRS airbag deploys, get fresh air promptly.
- A deploying SRS airbag releases hot gas. Occupants could get burned if they come into direct contact with the hot gas.

NOTE

When you sell your vehicle, we urge you to explain to the buyer that it is equipped with SRS airbags by alerting the buyer to the applicable section in this Owner's Manual.

■ **Components**

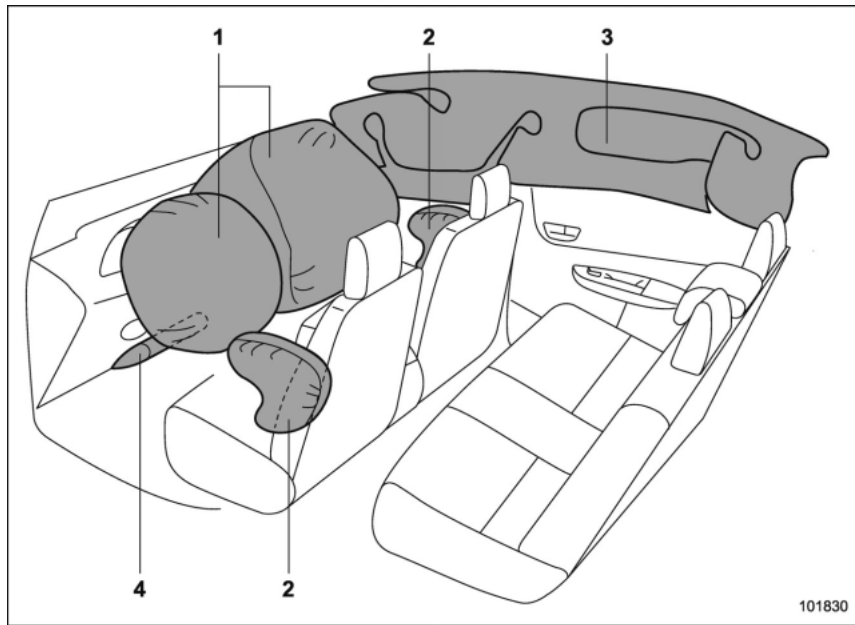

- 1) SRS frontal airbag
- 2) SRS side airbag
- 3) SRS curtain airbag
- 4) SRS knee airbag

The SRS airbags are stowed in the following locations.

Driver's SRS frontal airbag: in the center portion of the steering wheel

Front passenger's SRS frontal airbag: near the top of the dashboard under an "SRS AIRBAG" mark

SRS side airbag: in the door side of each front seat seatback which bears an "SRS AIRBAG" label

SRS curtain airbag: in the roof side (between the front pillar and a point behind the rear quarter glass)

An "SRS AIRBAG" mark is located at the top of each center pillar and rear pillar.

SRS knee airbag: under the steering column

101830

1-36 Seat, seatbelt and SRS airbags/SRS airbag (Supplemental Restraint System airbag)

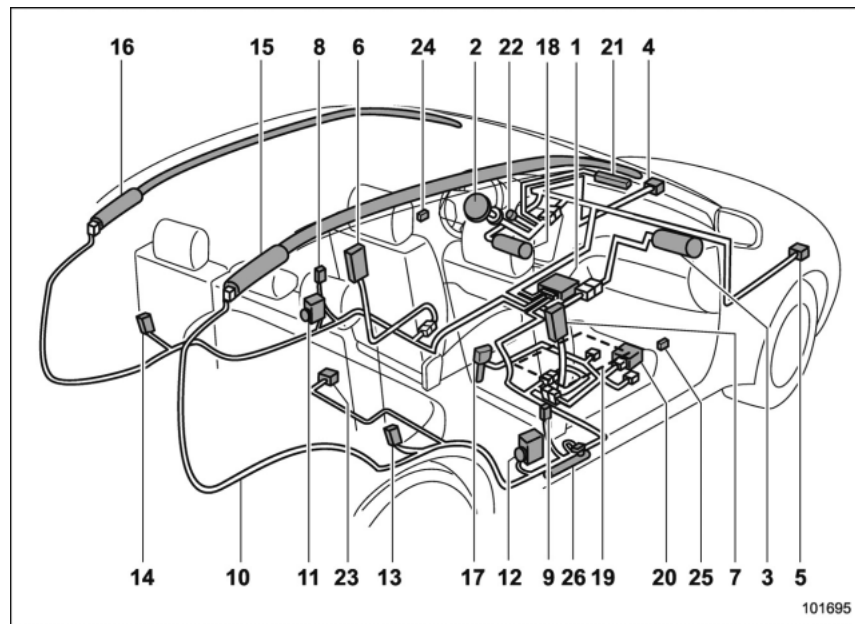

101695

- | | |
|--|---|
| 1) Airbag control module (including impact sensor) | 6) Side airbag module (driver's side) |
| 2) Frontal airbag module (driver's side) | 7) Side airbag module (front passenger's side) |
| 3) Frontal airbag module (front passenger's side) | 8) Side airbag sensor (center pillar left-hand side) |
| 4) Front sub sensor (left-hand side) | 9) Side airbag sensor (center pillar right-hand side) |
| 5) Front sub sensor (right-hand side) | 10) Airbag wiring |

- 11) Seatbelt pretensioner (driver's side)
- 12) Seatbelt pretensioner (front passenger's side)
- 13) Curtain airbag sensor (rear wheel house right-hand side)
- 14) Curtain airbag sensor (rear wheel house left-hand side)
- 15) Curtain airbag module (right-hand side)
- 16) Curtain airbag module (left-hand side)
- 17) Seatbelt buckle switch (front passenger's side)
- 18) Knee airbag module (driver's side)
- 19) Front passenger's occupant detection system sensor
- 20) Front passenger's occupant detection control module
- 21) Front passenger's frontal airbag ON and OFF indicator
- 22) SRS airbag system warning light
- 23) Satellite safing sensor (under the rear center seat)
- 24) Front door impact sensor (left-hand side)
- 25) Front door impact sensor (right-hand side)
- 26) Lap belt pretensioner (front passenger's side)

■ SUBARU advanced frontal airbag system

Your vehicle is equipped with a SUBARU advanced frontal airbag system that complies with the new advanced frontal airbag requirements in the amended Federal Motor Vehicle Safety Standard (FMVSS) No. 208.

The SUBARU advanced frontal airbag system automatically determines the deployment force of the driver's SRS frontal airbag at the time of deployment as well as whether or not to activate the front passenger's SRS frontal airbag and, if activated, the deployment force of the SRS frontal airbag at the time of deployment.

Your vehicle has warning labels on the driver's and front passenger's sun visors beginning with the phrase "EVEN WITH ADVANCED AIR BAGS" and a tag attached to the glove box lid beginning with the phrase "Even with Advanced Air Bags". Make sure that you carefully read the instructions on the warning labels and tag.

Always wear your seatbelt. The SUBARU advanced frontal airbag system is a supplemental restraint system and must be used in combination with a seatbelt. All occupants should wear a seatbelt or be seated in an appropriate child restraint

system.

The driver's SRS frontal airbag is stowed in the center portion of the steering wheel. The front passenger's SRS frontal airbag is stowed near the top of the dashboard under an "SRS AIRBAG" mark. Also, the driver's knee airbag is stowed in the bottom of the steering column.

In a moderate to severe frontal collision, the following components deploy.

- SRS frontal airbag for driver
- SRS frontal airbag for front passenger
- Knee airbag for driver
- SRS curtain airbag*¹

*1: When an offset frontal collision that is severe enough to deploy the front airbag occurs.

These components supplement the seatbelts by reducing the impact to the occupant's head, chest and knees.

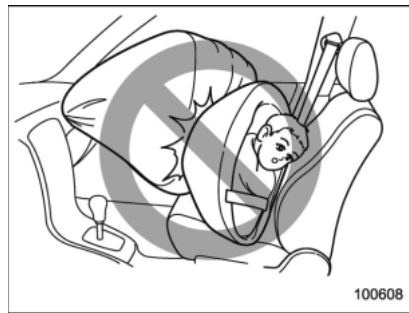

WARNING

NEVER INSTALL A REARWARD FACING CHILD SEAT IN THE FRONT SEAT. DOING SO RISKS SERIOUS INJURY OR DEATH TO THE CHILD BY PLACING THE CHILD'S HEAD TOO CLOSE TO THE SRS AIRBAG.

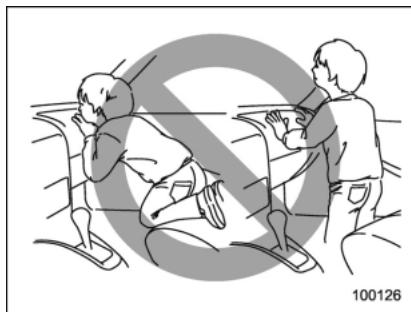

⚠ WARNING

Never allow a child to stand up, or to kneel on the front passenger's seat. The SRS airbag deploys with considerable force and can injure or even kill the child.



⚠ WARNING

Never hold a child on your lap or in your arms. The SRS airbag deploys with considerable force and can injure or even kill the child.



⚠ WARNING

The SRS airbag deploys with considerable speed and force. Occupants who are out of proper position when the SRS airbag deploys could suffer very serious injuries. Because the SRS airbag needs enough space for deployment, the driver should always sit upright and well back in the seat as far from the steering wheel as practical while still maintaining full vehicle control and the front passenger should move the seat as far back as possible and sit upright and well back in the seat.

It is also important to wear your

seatbelt to help avoid injuries that can result when the SRS airbag contacts an occupant not in proper position such as one thrown toward the front of the vehicle during pre-accident braking.

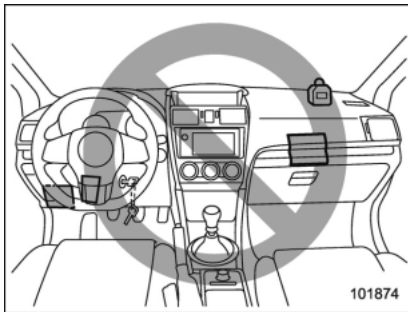

⚠ WARNING

- Do not put any objects over the steering wheel pad and dashboard. If the SRS frontal airbag deploys, these objects could interfere with its proper operation and could be propelled inside the vehicle, causing injury.
- Do not put any objects under the driver's side of the instrument

panel. If the knee airbag deploys, those objects could interfere with its proper operation and could be propelled inside the vehicle, causing injury.

- The key must not be attached to heavy, sharp or hard accessories, or another key. If the knee airbag deploys, those objects could interfere with its proper operation and could be propelled inside the vehicle and cause injury.

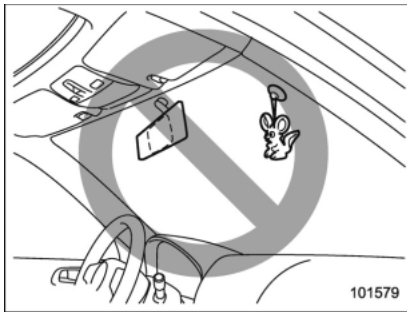

⚠ WARNING

Do not attach accessories to the windshield, or fit an extra-wide mir-

ror over the rear view mirror. If the SRS airbag deploys, those objects could become projectiles that could seriously injure vehicle occupants.

▼ Driver's SRS frontal airbag

The driver's SRS frontal airbag uses a dual stage inflator. The inflator operates in different ways depending on the severity of impact.

Have the system inspected by your SUBARU dealer immediately if the SRS airbag system warning light illuminates.

NOTE

The driver's SRS side airbag and SRS curtain airbag are not controlled by the SUBARU advanced frontal airbag system.

▼ Front passenger's SRS frontal airbag

The front passenger's SRS frontal airbag uses a dual stage inflator. The inflator operates in different ways depending on the severity of impact.

The occupant detection system sensor is installed under the seat upholstery and monitors the physique and posture of the front passenger. Using this information, the occupant detection system determines

whether the front passenger's SRS frontal airbag should be deployed or not.

The occupant detection system may not inflate the front passenger's SRS frontal airbag even when the driver's SRS frontal airbag deploys. This is normal. In this case, although the front passenger's SRS frontal airbag does not operate, the front passenger's seatbelt pretensioner operates with the driver's seatbelt pretensioner. For details about the seatbelt pretensioner, refer to "Front seatbelt pretensioners" 1-16.

**CAUTION**

Observe the following precautions. Failure to do so may prevent the SUBARU advanced frontal airbag system from functioning correctly or cause the system to fail.

- Do not apply any strong impact to the front passenger's seat such as by kicking.
- Do not let rear passengers rest their feet between the front seatback and seat cushion.
- Do not spill liquid on the front passenger's seat. If liquid is spilled, wipe it off immediately.
- Do not remove or disassemble the front passenger's seat.

- Do not install any accessory (such as an audio amplifier) other than a genuine SUBARU accessory under the front passenger's seat.
- Do not place anything (shoes, umbrella, etc.) under the front passenger's seat.
- Do not use the front passenger's seat with the head restraint removed.
- Do not leave any articles on the front passenger's seat or the seatbelt tongue and buckle engaged when you leave your vehicle.
- Do not put sharp object(s) on the seat or pierce the seat upholstery.
- Do not place a magnet near the seatbelt buckle and the seatbelt retractor.
- Do not use front seats with their backward-forward position and seatback not being locked into place securely. If any of them are not locked securely, adjust them again. For adjusting procedure, refer to "Manual seat" 1-4 (models equipped with manual seats only).

If the seatbelt buckle switch and/or front passenger's occupant detection system have failed, the SRS airbag system warning light will illuminate. Have the system inspected by your SUBARU dealer immediately if the SRS airbag system warning light illuminates.

If your vehicle has sustained impact, this may affect the proper function of the SUBARU advanced frontal airbag system. Have your vehicle inspected at your SUBARU dealer. Do not use the front passenger's seat while driving the vehicle to your SUBARU dealer.

NOTE

The front passenger's SRS side airbag and SRS curtain airbag are not controlled by the SUBARU advanced frontal airbag system.

▼ Passenger's frontal airbag ON and OFF indicators

Refer to "Front passenger's frontal airbag ON and OFF indicators" 3-15.

▼ Occupant detection system

The occupant detection system sensor is installed under the seat upholstery and monitors the physique and posture of the front passenger. Using this information, the occupant detection system determines whether the front passenger's SRS frontal

airbag should be deployed or not.

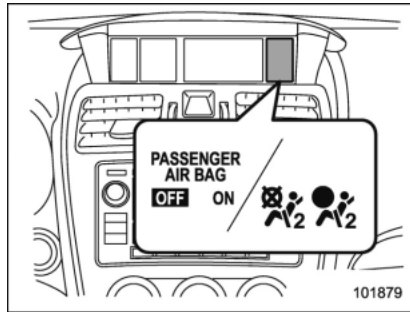

ON / : Front passenger's frontal airbag ON indicator

OFF / : Front passenger's frontal airbag OFF indicator

If the front passenger's seat cushion is wet, this may adversely affect the ability of the system to determine deployment. If the seat cushion is wet, the front passenger should stop sitting on the front passenger's seat. Wipe off liquid from the seat immediately, let the seat dry naturally and then check the SRS airbag system warning light as follows.

- If the SRS airbag system warning light illuminates, keep the seat dry until the warning light turns off. If the SRS airbag system warning light stays on even when the seat has dried, do not allow anyone to

sit on the front passenger's seat and have the system checked by your SUBARU dealer.

- If the SRS airbag system warning light does not illuminate, check that the front passenger's frontal airbag ON and OFF indicators work properly. If the indicators do not work properly, do not allow anyone to sit on the front passenger's seat and have the system checked by your SUBARU dealer.

Also, if luggage or electronic devices are placed on the front passenger's seat, this may adversely affect the ability of the system to determine deployment. This may prevent the front passenger's frontal airbag ON and OFF indicators from working properly. Check that the indicators work properly.

When the OFF indicator turns off and the ON indicator illuminates, the front passenger's frontal airbag may deploy during a collision. Remove luggage and electronic devices from the front passenger's seat.

CAUTION

Electrical devices, such as cell phones, laptops, portable music players, or electronic games, especially when connected to the accessory power outlet and placed on the

front passenger's seat or used by the person sitting in the front passenger's seat, may affect the operation of the occupant detection system. If the occupant detection system warning light illuminates or operates erratically when using an electronic device in the vehicle, at first try to relocate that device to avoid it creating any interference. If the device continues to cause interference, the use of that device in the vehicle should be discontinued.

NOTE

This device complies with Part 18 of the FCC Rules. This device may cause interference. If this device causes interference, consult the nearest SUBARU dealer. Also, for maintenance of the system, consult the nearest SUBARU dealer. A copy of the original declaration of conformity can be found in chapter 13.

▼ **Conditions in which front passenger's SRS frontal airbag is not activated**

The front passenger's SRS frontal airbag will not be activated when any of the following conditions are met regarding the front passenger's seat:

- The seat is empty.
- The seat is equipped with an appropriate child restraint system and an infant is restrained in it. (See WARNING that follows.)
- The front passenger's occupant detection system is malfunctioning.

 **WARNING**

NEVER INSTALL A REARWARD FACING CHILD SEAT IN THE FRONT PASSENGER'S SEAT EVEN IF THE FRONT PASSENGER'S SRS FRONTAL AIRBAG IS DEACTIVATED. Be sure to install it in the REAR seat in a correct manner. Also, it is strongly recommended that any forward facing child seat or booster seat be installed in the REAR seat, and that even children who have outgrown a child restraint system be also seated in the REAR seat. This is because children sitting in the front passenger's seat may be killed or severely injured should the front passenger's SRS frontal airbag deploy. REAR seats are the safest place for children.

 **CAUTION**

When the front passenger's seat is occupied by an infant in an appropriate child restraint system, observe the following precautions. Failure to do so may interfere with the proper operation of the occupant detection system, activating the front passenger's SRS frontal airbag even though that seat is occupied by the infant in the child restraint system.

- Do not place any article (including electronic devices) on the seat other than the infant in the child restraint system.
- Do not place more than one infant in the child restraint system.

▽ **If the front passenger's frontal airbag ON indicator illuminates and the OFF indicator turns off even when an infant or a small child is in a child restraint system (including booster seat)**

1. Turn the ignition switch to the "LOCK"/"OFF" position.
2. Remove the child restraint system from the seat.

3. By referring to the child restraint manufacturer's recommendations as well as the child restraint system installation procedures in "Child restraint systems" ¶1-20, correctly install the child restraint system.

4. Turn the ignition switch to the "ON" position and make sure that the front passenger's frontal airbag ON indicator turns off and the OFF indicator illuminates.

If still the ON indicator remains illuminated while the OFF indicator turns off, take the following actions.

- Ensure that no article is placed on the seat other than the child restraint system and the child occupant.
- Ensure that the backward-forward position and seatback of front passenger's seat are locked into place securely by moving the seat back and forth.

If the ON indicator still remains illuminated while the OFF indicator turns off after taking relevant corrective actions described above, relocate the child restraint system to the rear seat and immediately contact your SUBARU dealer for an inspection.

NOTE

When a child who has outgrown a child restraint system or a small adult is

seated in the front passenger's seat, the SUBARU advanced frontal airbag system may or may not activate the front passenger's SRS frontal airbag depending on the occupant's seating posture. Children should always wear a seatbelt when sitting in the seat irrespective of whether the airbag is deactivated or activated. If the front passenger's SRS frontal airbag is activated (the ON indicator remains illuminated while the OFF indicator turns off), ensure that no article is placed on the seat other than the occupant.

If the ON indicator still remains illuminated while the OFF indicator turns off despite the fact that the actions noted above have been taken, seat the child/small adult in the rear seat and immediately contact your SUBARU dealer for an inspection. Even if the system has passed the dealer inspection, it is recommended that on subsequent trips the child/small adult always take the rear seat.

Children who have outgrown a child restraint system should always wear the seatbelt irrespective of whether the airbag is deactivated or activated.

▼ **Conditions in which front passenger's SRS frontal airbag is activated**

The front passenger's SRS frontal airbag will be activated for deployment upon impact when any of the following conditions are met regarding the front passenger's seat.

- When the seat is occupied by an adult.
- When certain items (e.g. jug of water) are placed on the seat.

▽ **If the passenger's frontal airbag OFF indicator illuminates and the ON indicator turns off even when the front passenger's seat is occupied by an adult**

This can be caused by the adult incorrectly sitting in the front passenger's seat.

1. Turn the ignition switch to the "LOCK"/"OFF" position.
2. Ask the front passenger to set the seatback to the upright position, sit up straight in the center of the seat cushion, correctly fasten the seatbelt, position his/her legs out forward, and adjust the seat to the rearmost position.
3. Turn the ignition switch to the "ON" position.

If the OFF indicator remains illuminated while the ON indicator remains off, take the following actions.

1. Turn the ignition switch to the "LOCK"/"OFF" position.
2. Make sure that the front passenger does not use a blanket, seat cushion, seat cover, seat heater or massager, etc.
3. If wearing excessive layers of clothing, the front passenger should remove any unnecessary items before sitting in the front passenger's seat, or should sit in a rear seat.
4. Turn the ignition switch to the "ON" position and wait 6 seconds to allow the system to complete self-checking. Following the system check, both indicators turn off for 2 seconds. Now, the ON indicator should illuminate while the OFF indicator remains off.

If the OFF indicator still remains illuminated while the ON indicator remains off, ask the occupant to move to the rear seat and immediately contact your SUBARU dealer for an inspection.

▼ **How to contact the vehicle manufacturer concerning modifications for persons with disabilities that may affect the advanced airbag system**

Changing or moving any parts of the front seats, rear seat, seatbelts, front bumper, front side frame, radiator panel, instrument panel, combination meter, steering wheel,

steering column, tire, suspension or floor panel can affect the operation of the SUBARU advanced airbag system. If you have any questions, you may contact the following SUBARU distributors.

<Continental U.S., Alaska and the District of Columbia>

Subaru of America, Inc.

Customer Dealer Services Department

P.O. Box 6000

Cherry Hill, NJ 08034-6000

1-800-SUBARU3 (1-800-782-2783)

<Hawaii>

Subaru Hawaii

2850 Pukoloa Street, Suite 202,

Honolulu, HI 96819-4467

808-839-2273

<Guam>

Shen's Corporation dba Prestige Automobile

491, East Marine Corps Drive, Route 1

Dededo, Guam 96921-6255

671-633-2698

<Puerto Rico>

Trebol Motors

P.O. Box 11204, San Juan, Puerto Rico

00910

787-793-2828

<Canada>

Subaru Canada, Inc.

Consumer Support Department

560 Suffork Court, Mississauga, Ontario

L5R 4J7

1-800-894-4212

There are currently no SUBARU distributors in any other U.S. territories. If you are in such an area, please contact the SUBARU distributor or dealer from which you bought your vehicle.

▼ Operation

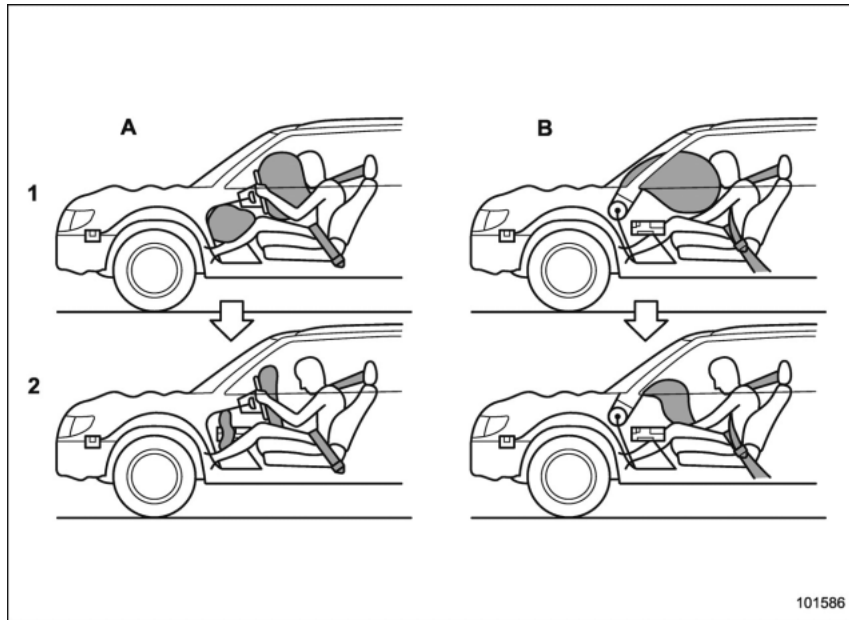

- A) Driver's side
 B) Passenger's side
 1) SRS AIRBAGs deploy as soon as a collision occurs.
 2) After deployment, SRS AIRBAGs start to deflate immediately so that the driver's vision is not obstructed.

The SRS airbags can function only when the ignition switch is in the "ON" position. The SUBARU advanced frontal airbag system is designed to determine the activation or deactivation condition of the front passenger's SRS frontal airbag depending on the characteristic of item (s) or person on the front passenger's seat monitored by the front passenger's occupant detection system sensor. For this reason, only the driver's SRS frontal airbag may deploy in the event of a collision, but this does not mean failure of the system.

If the front sub sensors and the impact sensors in the airbag control module detect a predetermined amount of force during a frontal collision, the control module sends signals to the airbag module(s) (only driver's module or both driver's and front passenger's modules) instructing the module(s) to inflate the SRS frontal airbag(s). On driver's side, the SRS knee airbag also inflates with the SRS frontal airbag.

The driver's and front passenger's SRS frontal airbags use dual stage inflators. The two inflators of each airbag are triggered either sequentially or simultaneously, depending on the severity of impact, in the case of the driver's SRS frontal airbag and depending on the severity of impact and the characteristic of item(s) or person on the seat in the case of the front passenger's SRS frontal airbag.

After deployment, the SRS airbag immediately starts to deflate so that the driver's vision is not obstructed. The time required from detecting impact to the deflation of the SRS airbag after deployment is shorter than the blink of an eye.

Both when only the driver's SRS frontal airbag deploys and the driver's and front passenger's SRS frontal airbags deploy, the driver's and front passenger's seatbelt pretensioners operate at the same time.

Although it is highly unlikely that the SRS airbag would activate in a non-accident situation, should it occur, the SRS airbag will deflate quickly, not obscuring vision and will not interfere with the driver's ability to maintain control of the vehicle.

When the SRS airbag deploys, a sudden, fairly loud inflation noise will be heard and

some smoke will be released. These occurrences are a normal result of the deployment. This smoke does not indicate a fire in the vehicle.

 **CAUTION**

Do not touch the SRS airbag system components around the steering wheel and dashboard with bare hands right after deployment. Doing so can cause burns because the components can be very hot as a result of deployment.

The driver's SRS frontal airbag and front passenger's SRS frontal airbag are designed to deploy in the event of an accident involving a moderate to severe frontal collision. They are not designed to deploy in most lesser frontal impacts because the necessary protection can be achieved by the seatbelt alone. Also, they are not designed to deploy in most side or rear impacts or in most roll-over accidents because deployment of only the driver's SRS frontal airbag or both driver's and front passenger's SRS frontal airbags would not help the occupant in those situations. The driver's and front passenger's SRS frontal airbags are designed to function on a one-time-only basis.

SRS airbag deployment depends on the level of force experienced in the passenger compartment during a collision. That level differs from one type of collision to another, and it may have no bearing on the visible damage done to the vehicle itself.

- ▽ **Example of accident in which the driver's/driver's and front passenger's SRS frontal airbag(s) will most likely deploy**

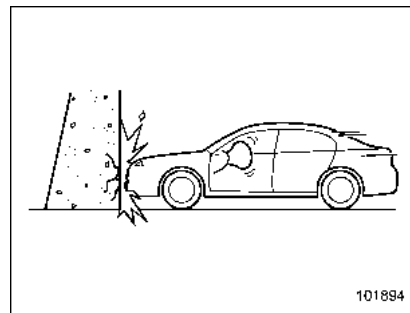

A head-on collision against a thick concrete wall at a vehicle speed of 12 to 19 mph (20 to 30 km/h) or higher activates only the driver's SRS frontal airbag or both driver's and front passenger's SRS frontal airbags. The airbag(s) will also be activated when the vehicle is exposed to a frontal impact similar in fashion and

magnitude to the collision described above.

▽ **Examples of the types of accidents in which it is possible that the driver's/driver's and front passenger's SRS frontal airbag(s) will deploy**

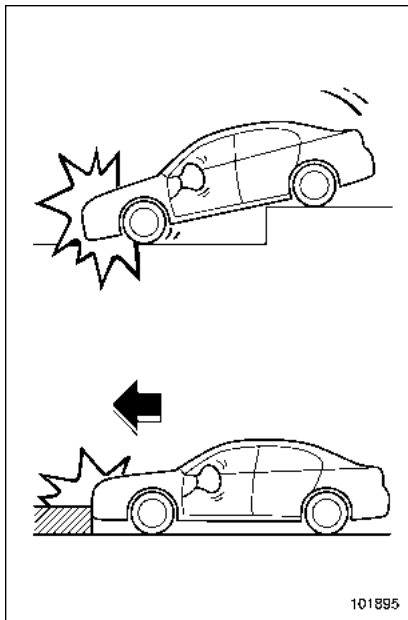

Only the driver's SRS frontal airbag or both driver's and front passenger's SRS frontal airbags may be activated when the vehicle sustains a hard impact in the undercarriage area from the road surface (such as when the vehicle plunges into a deep ditch, is severely impacted or knocked hard against an obstacle on the road such as a curb).

▽ Examples of the types of accidents in which deployment of the driver's/driver's and front passenger's SRS frontal airbag(s) is unlikely to occur

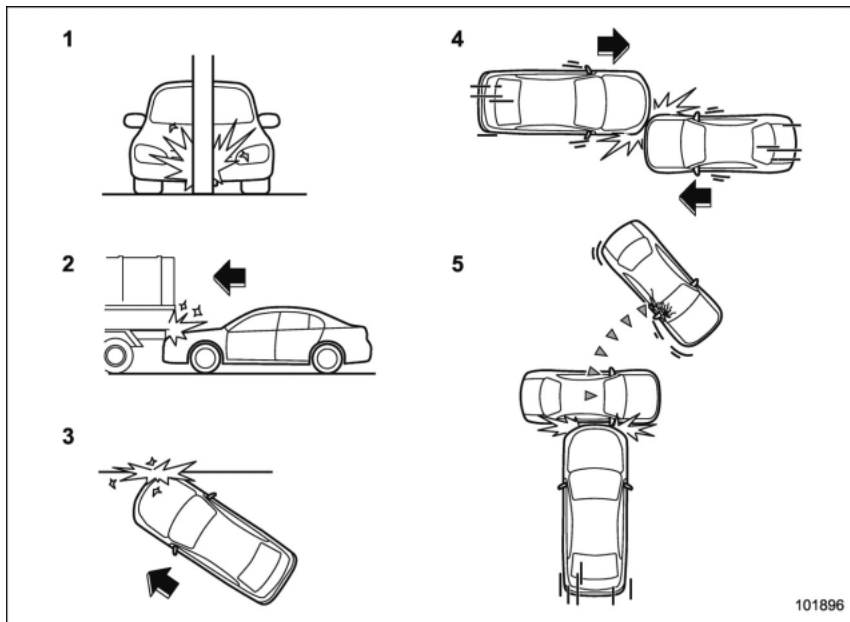

- 1) The vehicle strikes an object, such as a telephone pole or sign pole.
- 2) The vehicle slides under the load bed of a truck.
- 3) The vehicle sustains an oblique offset frontal impact.
- 4) The vehicle sustains an offset frontal collision.
- 5) The vehicle strikes an object that can move or deform, such as a parked vehicle.

There are many types of collisions which might not necessarily require deployment of driver's/driver's and front passenger's SRS frontal airbag(s). In the event of accidents like those illustrated, the driver's/driver's and front passenger's SRS frontal airbag(s) may not deploy depending on the level of accident forces involved.

▽ Examples of the types of accidents in which the driver's/driver's and front passenger's SRS frontal airbag(s) will basically not deploy

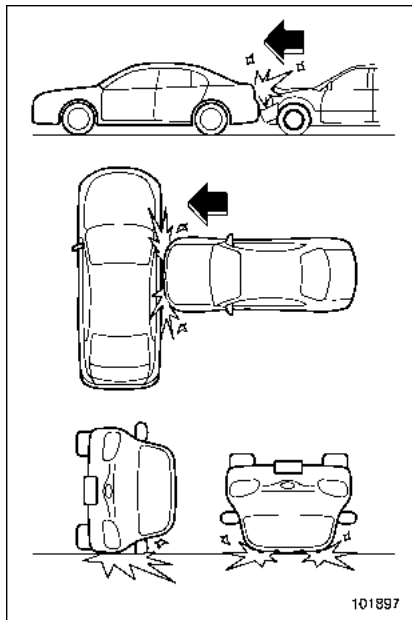

The driver's and front passenger's SRS

frontal airbags are designed not to deploy in most cases if the vehicle is struck from the side or from behind, or if it rolls onto its side or roof, or if it is involved in a low-speed frontal collision.

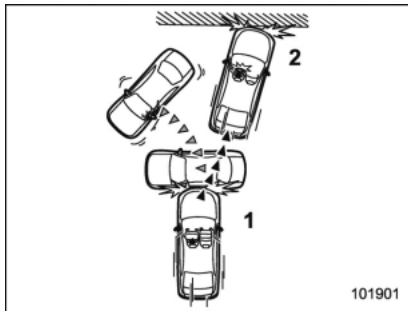

- 1) First impact
- 2) Second impact

In an accident where the vehicle is impacted more than once, the driver's and/or front passenger's SRS frontal airbag(s) will deploy only once on the first impact.

Example: In the case of a double collision, first with another vehicle, then against a concrete wall in immediate succession, once either or both of the driver's and front passenger's SRS frontal airbags is/are activated on the first impact, it/they will not

be activated on the second impact.

■ SRS side airbag and SRS curtain airbag



The SRS side airbag is stored in the door side of each front seat seatback.

In a moderate to severe side impact collision, the SRS side airbag on the impacted side of the vehicle deploys between the occupant and the door panel and supplements the seatbelt by reducing the impact on the occupant's chest and waist. The SRS side airbag operates only for front seat occupants.

The SRS curtain airbag on each side of the cabin is stored in the roof side (between the front pillar and a point over the rear seat).

In a moderate to severe side impact

collision, the SRS curtain airbag on the impacted side of the vehicle deploys between the occupant and the side window and supplements the seatbelt by reducing the impact on the occupant's head.

In a frontal collision, SRS curtain airbags on both sides of the vehicle deploy between the occupant and the side window and supplement the seatbelt by reducing the impact to the occupant's head.

⚠ WARNING

The SRS side airbag and SRS curtain airbag are designed only to be a supplement to the primary protection provided by the seatbelt. They do not do away with the need to fasten seatbelts. It is also important to wear your seatbelt to help avoid injuries that can result when an occupant is not seated in a proper upright position.



⚠ WARNING

- Do not sit or lean unnecessarily close to either front door. The SRS side airbag is stored in both front seat seatbacks next to the door, and it provides protection by deploying rapidly (faster than the blink of an eye) in the event of a side impact collision. However, the force of SRS side airbag deployment may cause injuries if your head or other parts of the body are too close to the SRS side airbag.
- Since your vehicle is equipped with SRS curtain airbags, do not sit or lean unnecessarily close to

the front or rear door on either side. Also, do not put your head, arms or hands out of the window. The SRS curtain airbag on each side of the cabin is stored in the roof side (between the front pillar and a point over the rear seat), and it provides protection by deploying rapidly (faster than the blink of an eye) in the event of a side impact. However, the force of its deployment may cause injuries if your head is too close to it.



⚠ WARNING

Do not rest your arm on either front door or its internal trim. It could be

injured in the event of SRS side airbag deployment.

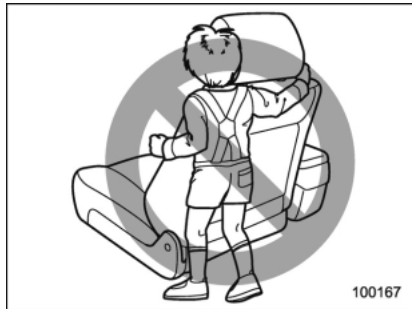
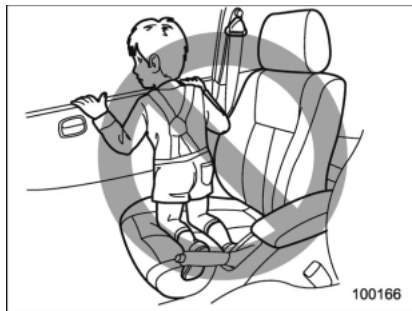

⚠ WARNING

- Never allow a child to kneel on the front passenger's seat facing the side window or to wrap his/her arms around the front seat seatback. In the event of an accident, the force of the SRS side airbag deployment could injure the child seriously because his/her head or arms or other parts of the body are too close to the SRS side airbag.

Since your vehicle is also equipped with a front passenger's SRS frontal airbag, children aged 12 and under should be placed in the rear seat anyway and should be properly restrained at all times.

- Never allow a child to kneel on any passenger's seat facing the side window or put their head, arms and hands out of the window. In the event of an accident, the force of the SRS curtain airbag deployment could injure the child seriously because his/her head is close to the SRS curtain airbag.

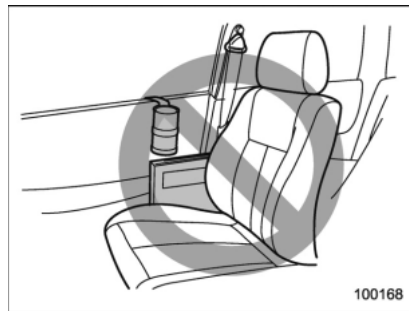

⚠ WARNING

- Do not attach accessories to the door trim or near either SRS side airbags and do not place objects near the SRS side airbags. In the event of the SRS side airbag deployment, they could be propelled dangerously toward the vehicle's occupants and cause injuries.
- Do not attach a hands-free microphone or any other accessory to a front pillar, a center pillar, a rear pillar, the windshield, a side window, an assist grip, or any other cabin surface that would be near a deploying SRS curtain airbag.

A hands-free microphone or other accessory in such a location could be propelled through the cabin with great force by the curtain airbag, or it could prevent correct deployment of the curtain airbag. In either case, the result could be serious injuries.

- Never hang or place coat hangers or other hard or pointed objects near the side windows. If such items are present when the SRS curtain airbags deploy, they could be thrown through the passenger compartment and cause serious injuries. They could also prevent proper operation of the SRS curtain airbags.

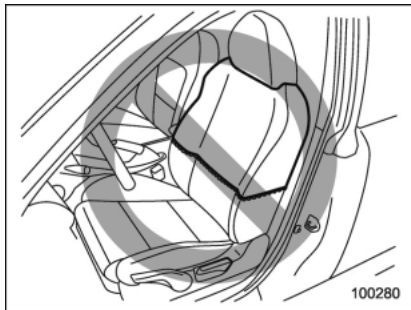

WARNING

Do not put any kind of cover or clothes or other objects over either front seatback and do not attach labels or stickers to the front seat surface on or near the SRS side airbag. They could prevent proper deployment of the SRS side airbag, reducing protection available to the front seat's occupant.

▼ Operation

The SRS side airbag and SRS curtain airbag can function only when the ignition switch is in the "ON" position.

The driver's and front passenger's SRS side airbags and SRS curtain airbags deploy independently of each other since each has its own impact sensor. Therefore, they may not both deploy in the same accident. Also, the SRS side airbag and SRS curtain airbag deploys independently of the driver's and front passenger's SRS frontal airbags in the steering wheel and instrument panel.

An impact sensor, which senses impact force, is located in each of the following locations.

- In the left and right front doors

- In the left and right center pillars
- In the left and right rear wheel houses
- Under the rear center seat

If the impact sensor that is located under the rear center seat and one of the center pillar impact sensors or front door impact sensors together sense an impact force above a predetermined level in a side collision, the control module causes both the SRS side airbag and curtain airbag on the impacted side to inflate regardless of whether the rear wheel house impact sensor on the same side senses an impact.

If the impact sensor that is located under the rear center seat and one of the rear wheel house impact sensors together sense an impact force above a predetermined level in a side collision, the control module causes only the SRS curtain airbag on the impacted side to inflate.

Even if a frontal collision occurs, the SRS curtain airbags will deploy when the front sensor and the control unit determine that the impact results from an offset frontal collision.

The SRS curtain airbags are designed to deploy when the driver's SRS frontal airbag deploys or the driver's and passenger's SRS frontal airbags deploy in a

frontal collision, and also when the system determines that the collision is an offset frontal collision. The SRS curtain airbags are basically designed not to deploy in a frontal collision when the SRS frontal airbags do not deploy or the system determines that the collision is other than an offset frontal collision.

After the deployment, the SRS side airbag immediately starts to deflate. The time required from detection of an impact to deflation of an SRS side airbag after deployment is shorter than the blink of an eye.

The SRS curtain airbag remains inflated for a while following deployment then slowly deflates.

The SRS side airbag and SRS curtain airbag deploy even when no one occupies the seat on the side on which an impact is applied.

When the SRS side airbag and SRS curtain airbag deploy, a sudden, fairly loud inflation noise will be heard and some smoke will be released. These occurrences are a normal result of the deployment. This smoke does not indicate a fire in the vehicle.

 **CAUTION**

Do not touch the SRS side airbag system components around the front seat seatback with bare hands right after deployment. Doing so can cause burns because the components can be very hot as a result of deployment.

After deployment, do not touch any part of the SRS curtain airbag system (from the front pillar to the part of the roof side over the rear seat). Doing so can cause burns because the components can be very hot as a result of deployment.

The SRS side airbag and SRS curtain airbag are designed to deploy in the event of an accident involving a moderate to severe side impact collision. They are not designed to deploy in most lesser side impact. Also, they are not designed to deploy in most frontal or most rear impacts because SRS side airbag and SRS curtain airbag deployment would not help the occupant in those situations.

Each SRS side airbag and SRS curtain airbag are designed to function on a one-time-only basis.

SRS side airbag and SRS curtain airbag

deployment depend on the level of force experienced in the passenger compartment during a side impact collision. That level differs from one type of collision to another, and it may have no bearing on the visible damage done to the vehicle itself.

- ▽ Example of the type of accident in which the SRS side airbag will most likely deploy.

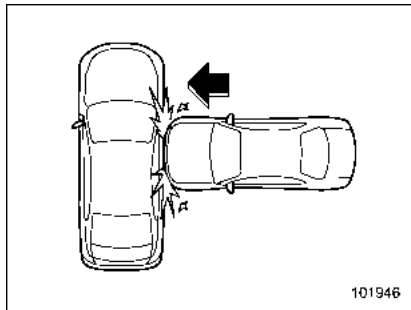

A severe side impact near the front seat.

- ▽ Examples of the types of accidents in which the SRS curtain airbag will most likely deploy.

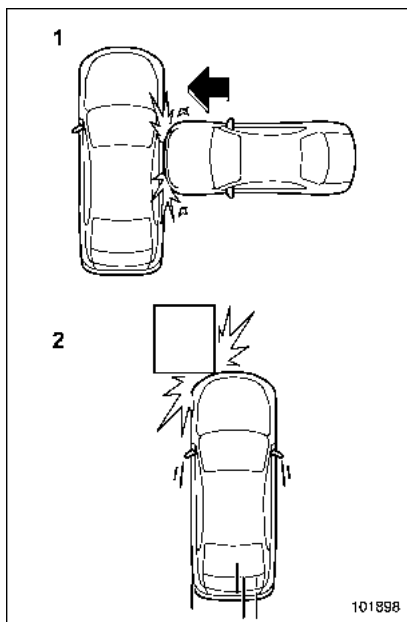

- 1) A severe side impact near the front seat or the rear seat.
- 2) An offset frontal collision that is severe enough to deploy the front airbag.

▽ **Examples of the types of accidents in which the SRS side airbag and the SRS curtain airbag are unlikely to deploy.**

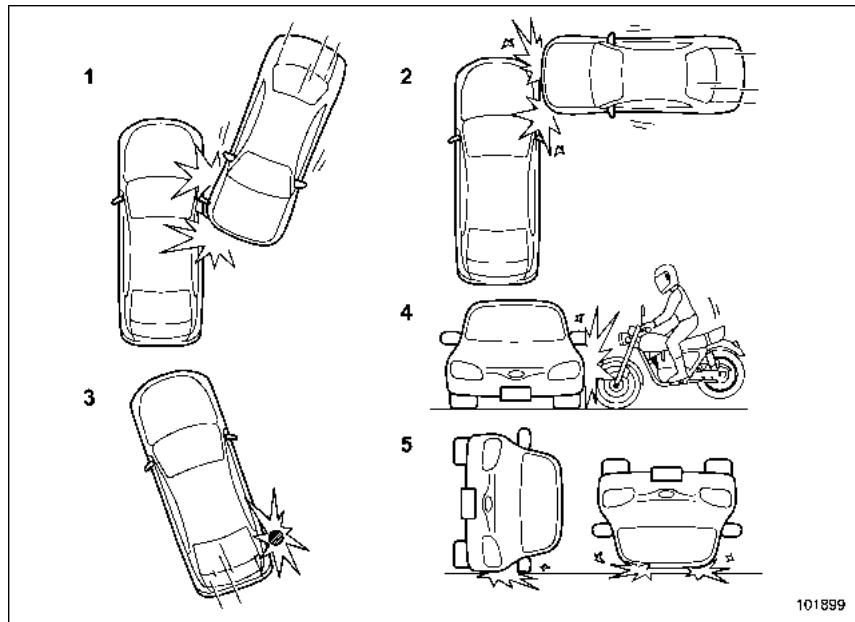

- 1) The vehicle is involved in an oblique side-on impact.
- 2) The vehicle is involved in a side-on impact in an area outside the vicinity of the passenger compartment.
- 3) The vehicle strikes a telephone pole or similar object.
- 4) The vehicle is involved in a side-on impact from a motorcycle.
- 5) The vehicle rolls onto its side or the roof.

There are many types of collisions which might not necessarily require the SRS side airbag and SRS curtain airbag deployment. In the event of accidents like those illustrated, the SRS side airbag and SRS curtain airbag may not deploy depending on the level of accident forces involved.

- ▽ **Examples of the types of accidents in which the SRS side airbag and SRS curtain airbag are not designed to deploy in most cases**

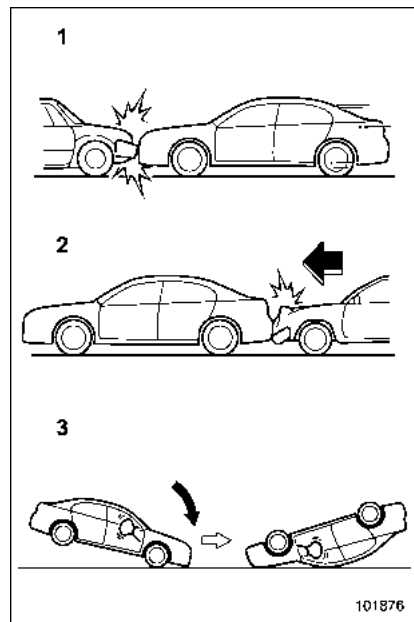

- 1) The vehicle is involved in frontal collision with another vehicle (moving or station-

- ary).
 2) The vehicle is struck from behind.
 3) The vehicle pitches end over end.

In the event of accidents like those illustrated, the SRS side airbag and SRS curtain airbag are not designed to deploy in most cases.

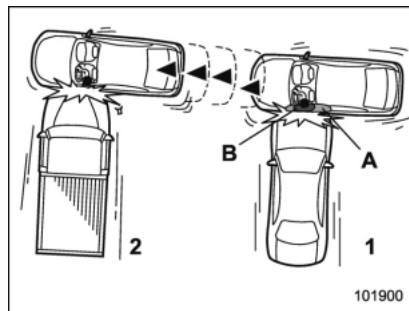

- 1) First impact
 2) Second impact
 A) SRS curtain airbag
 B) SRS side airbag

In an accident where the vehicle is struck from the side more than once, the SRS side airbag and SRS curtain airbag deploy only once on the first impact.

Example: In the case of a double impact collision, first with one vehicle and immediately followed by another from the

same direction, once the SRS side airbag and SRS curtain airbag are activated on the first impact, they will not be activated on the second.

■ SRS airbag system monitors

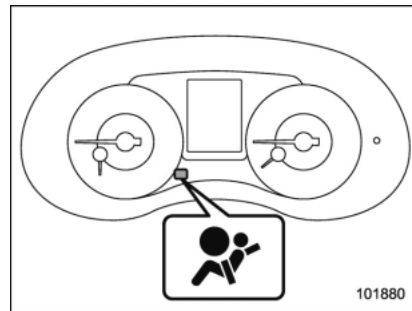

A diagnostic system continually monitors the readiness of the SRS airbag system (including front seatbelt pretensioners) while the vehicle is being driven. The SRS airbag system warning light will show normal system operation by illuminating for approximately 6 seconds when the ignition switch is turned to the "ON" position.

The following components are monitored by the indicator:

- Front sub sensor

- Right-hand side
- Left-hand side
- Airbag control module (including impact sensor)
- Frontal airbag module
 - Driver's side
 - Front passenger's side
- Knee airbag module (driver's side)
- Side airbag sensor
 - Center pillar right-hand side
 - Center pillar left-hand side
- Front door impact sensor
 - Right-hand side
 - Left-hand side
- Side airbag module
 - Driver's side
 - Front passenger's side
- Curtain airbag sensor
 - Rear wheel house right-hand side
 - Rear wheel house left-hand side
- Curtain airbag module
 - Right-hand side
 - Left-hand side
- Satellite safing sensor (under the rear center seat)
- Seatbelt pretensioner
 - Driver's side
 - Front passenger's side
- Lap belt pretensioner (front passenger's side)

- Seatbelt buckle switch (front passenger's side)
- Front passenger's occupant detection system sensor
- Front passenger's occupant detection control module
- Front passenger's frontal airbag ON and OFF indicator
- All related wiring

 **WARNING**

If the warning light exhibits any of the following conditions, there may be a malfunction in the seatbelt pretensioners and/or SRS airbag system. Immediately take your vehicle to your nearest SUBARU dealer to have the system checked. Unless checked and properly repaired, the seatbelt pretensioners and/or SRS airbag will not operate properly in the event of a collision, which may increase the risk of injury.

- Flashing or flickering of the warning light
- No illumination of the warning light when the ignition switch is first turned to the "ON" position
- Continuous illumination of the warning light

- Illumination of the warning light while driving

■ SRS airbag system servicing

 **WARNING**

- When discarding an airbag module or scrapping the entire vehicle damaged by a collision, consult your SUBARU dealer.
- The SRS airbag has no user-serviceable parts. Do not use electrical test equipment on any circuit related to the SRS airbag system. For required servicing of the SRS airbag, consult your nearest SUBARU dealer. Tampering with or disconnecting the system's wiring could result in accidental inflation of the SRS airbag or could make the system inoperative, which may result in serious injury.

 **CAUTION**

If you need service or repair in areas indicated in the following list, have the work performed by an author-

ized SUBARU dealer. The SRS airbag control module, impact sensors and airbag modules are stored in these areas.

- Under the center console
- On both the right and left sides at the front of the vehicle
- Steering wheel and column and nearby areas
- Bottom of the steering column and nearby areas
- Top of the dashboard on front passenger's side and nearby areas
- Each front seat and nearby area
- Inside each center pillar
- Inside each front door
- In each roof side (from the front pillar to a point over the rear seat)
- Between the rear seat cushion and rear wheel house on each side
- Under the rear center seat

In the event that the SRS airbag is deployed, replacement of the system should be performed only by an authorized SUBARU dealer. When the components of the SRS airbag system are

replaced, use only genuine SUBARU parts.

NOTE

In the following cases, contact your SUBARU dealer as soon as possible.

- The front part of the vehicle was involved in an accident in which only the driver's SRS frontal airbag or both driver's and front passenger's SRS frontal airbags did not deploy.
- The pad of the steering wheel, the cover over the front passenger's SRS frontal airbag, or either roof side (from the front pillar to a point over the rear seat) is scratched, cracked, or otherwise damaged.
- The center pillar, front door, rear wheel house or rear sub frame, or an area near these parts, was involved in an accident in which the SRS side airbag and SRS curtain airbag did not deploy.
- The fabric or leather of either front seatback is cut, frayed, or otherwise damaged.
- The rear part of the vehicle was involved in an accident in which no SRS airbag was deployed.

■ Precautions against vehicle modification



WARNING

To avoid accidental activation of the system or rendering the system inoperative, which may result in serious injury, no modifications should be made to any components or wiring of the SRS airbag system. This includes following modifications.

- Installation of custom steering wheels
- Attachment of additional trim materials to the dashboard
- Installation of custom seats
- Replacement of seat fabric or leather
- Installation of additional fabric or leather on the front seat
- Attachment of a hands-free microphone or any other accessory to a front pillar, a center pillar, a rear pillar, the windshield, a side window, an assist grip, or any other cabin surface that would be near a deploying SRS curtain airbag.

- Installation of additional electrical/electronic equipment such as a mobile two-way radio on or near the SRS airbag system components and/or wiring is not advisable. This could interfere with proper operation of the SRS airbag system.



CAUTION

Do not perform any of the following modifications. Such modifications can interfere with proper operation of the SRS airbag system.

- Attachment of any equipment (bush bar, winches, snow plow, skid plate, etc.) other than genuine SUBARU accessory parts to the front end.
- Modification of the suspension system or front end structure.
- Installation of a tire of different size and construction from the tires specified on the vehicle placard attached to the driver's door pillar or specified for individual vehicle models in this Owner's Manual.
- Attachment of any equipment (side steps or side sill protectors,

etc.) other than genuine SUBARU accessory parts to the side body.

Always consult your SUBARU dealer if you want to install any accessory parts on your vehicle.

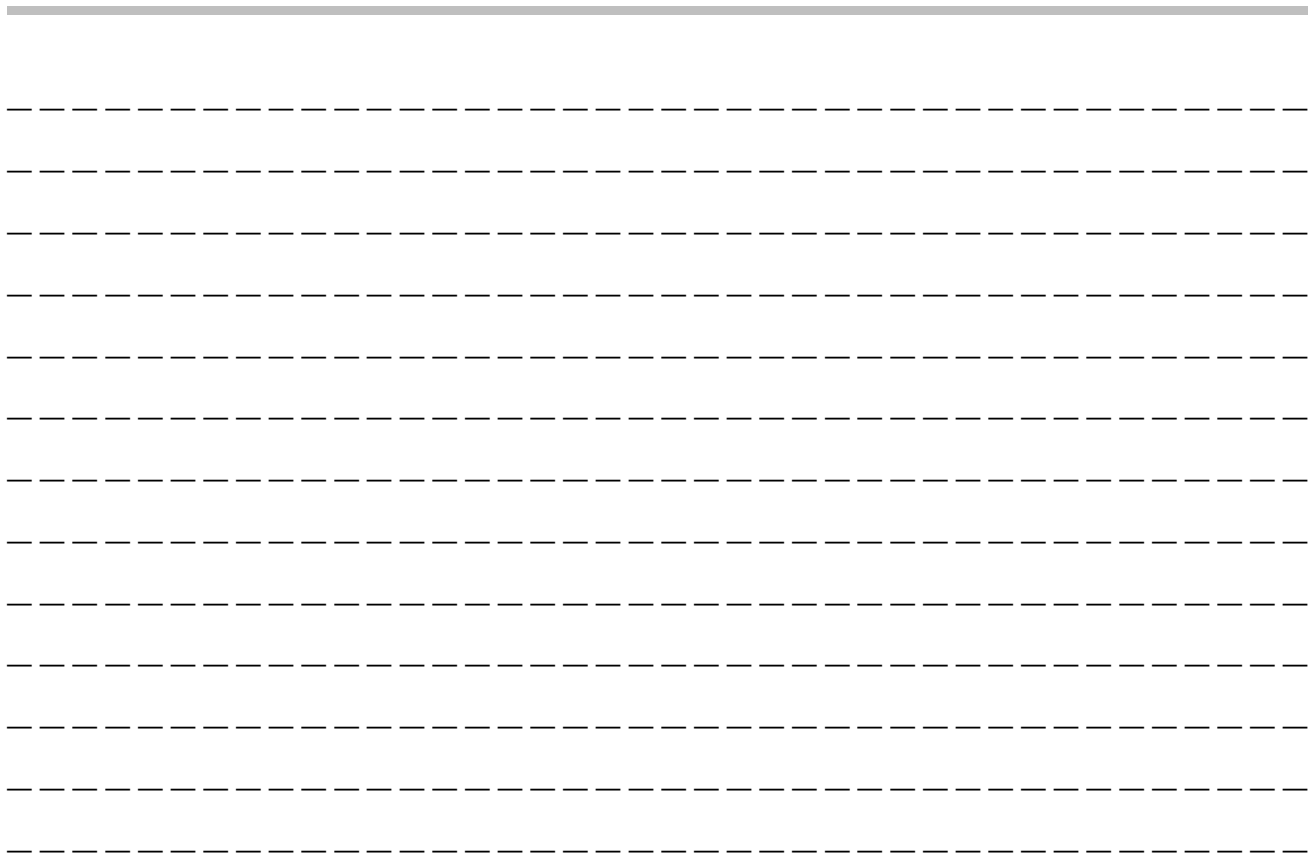

Keys	2-2	Selecting audible signal operation (models without “keyless access with push-button start system”)	2-20
Key number plate	2-2	Replacing the battery	2-20
Immobilizer	2-2	Replacing lost transmitters	2-20
Security indicator light	2-3	Welcome lighting (if equipped)	2-20
Key replacement	2-3	Alarm system	2-21
Certification for immobilizer system	2-3	System operation.....	2-22
Door locks	2-4	Activating and deactivating the alarm system	2-22
Locking and unlocking from the outside	2-4	If you have accidentally triggered the alarm system	2-22
Locking and unlocking from the inside	2-5	Arming the system	2-23
Battery drainage prevention function	2-6	Disarming the system	2-25
Power door locking switches	2-7	Valet mode	2-26
Key lock-in prevention function	2-7	Passive arming (models without “keyless access with push-button start system”)	2-26
Keyless access with push-button start system (if equipped)	2-8	Tripped sensor identification	2-27
Safety precautions	2-8	Shock sensors (dealer option).....	2-27
Locking and unlocking with “keyless access” entry function.....	2-11	Child safety locks	2-28
Selecting audible signal operation	2-14	Windows	2-28
Warning chimes and warning indicator	2-14	Power window operation by driver	2-29
Disabling keyless access function	2-15	Power window operation by passengers.....	2-31
When access key does not operate properly	2-15	Initialization of power window	2-32
Replacing battery of access key	2-15	Trunk lid	2-32
Replacing access key	2-16	To open and close the trunk lid from outside.....	2-32
Certification for keyless access with push-button start system	2-16	To open the trunk lid from inside.....	2-32
Remote keyless entry system	2-17	Internal trunk lid release handle	2-33
Locking the doors	2-19	Moonroof (if equipped)	2-34
Unlocking the doors	2-19	Moonroof switches	2-35
Opening the trunk lid.....	2-19	Sun shade	2-36
Vehicle finder function.....	2-19		
Sounding a panic alarm.....	2-20		

Keys

NOTE

For models with “keyless access with push-button start system”, refer to “Keyless access with push-button start system” 2-8.

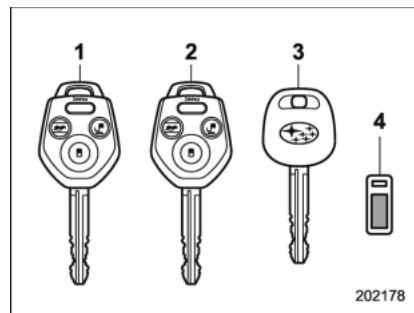

- 1) Master key
- 2) Submaster key
- 3) Sub key
- 4) Key number plate

Three types of keys are provided for your vehicle.



CAUTION

Do not attach a large key holder or key case to either key. If it bangs

against your knees while you are driving, it could turn the ignition switch from the “ON” position to the “ACC” or “LOCK” position, thereby stopping the engine.

■ Key number plate

The key number is stamped on the key number plate attached to the key set. Write down the key number and keep it in another safe place, not in the vehicle. This number is needed to make a replacement key if you lose your key or lock it inside the vehicle. Refer to “Key replacement” 2-3.

Immobilizer

The immobilizer system is designed to prevent an unauthorized person from starting the engine. Only keys registered with your vehicle’s immobilizer system can be used to operate your vehicle. This system, however, is not a 100% anti-theft guaranty.

For models with “keyless access with push-button start system”:

If you press the push-button ignition switch when carrying an unregistered access key, the switch will not turn to the “ON” position and the engine will not start.

For models without “keyless access with push-button start system”:

Even if an unregistered key fits into the ignition switch and can be turned to the “START” position, the engine will automatically stop after several seconds.

If the engine does not start, perform either of the following procedures.

- Perform the procedure described in “Starting engine” 9-17 (models with “keyless access with push-button start system”).
- Pull out the key once before trying again (models without “keyless access with push-button start system”). Refer to

“Ignition switch (models without push-button start system)” 3-4.



CAUTION

- Do not place the key under direct sunlight or anywhere it may become hot.
- Do not get the key wet. If the key gets wet, wipe it dry with a cloth immediately.
- Do not modify or remove the system. If modified or removed, the proper operation of the system cannot be guaranteed.

NOTE

- To protect your vehicle from theft, please pay close attention to the following security precautions:
 - Never leave your vehicle unattended with its keys inside.
 - Before leaving your vehicle, close all windows and the moonroof, and lock the doors.
 - Do not leave spare keys or any record of your key number in the vehicle.
- The vehicle has a maintenance-free type immobilizer system.

■ Security indicator light

Refer to “Security indicator light” 3-30.

■ Key replacement

Your key number plate will be required if you ever need a replacement key made. Any new key must be registered for use with your vehicle’s immobilizer system before it can be used. The maximum number of keys that can be registered for use with one vehicle is as follows.

- Four (models without “keyless access with push-button start system”)
- Seven (models with “keyless access with push-button start system”)

One key that has already been registered is required in order to register a new key.

If you lose a key, the lost key’s ID code still remains in the memory of the vehicle’s immobilizer system. For security reasons, the lost key’s ID code should be erased from the memory. To erase the lost key’s ID code, all keys that will be used are required.

For details about new key registration and erasing the lost key’s ID code, contact your SUBARU dealer.

■ Certification for immobilizer system

For models with “keyless access with push-button start system”:

Refer to “Certification for keyless access with push-button start system” 2-16.

For models without “keyless access with push-button start system”:

▼ U.S.-spec. models

FCC ID: MOZRI-38BFH



CAUTION

FCC WARNING

Changes or modifications not expressly approved by the party responsible for compliance could void the user’s authority to operate the equipment.

NOTE

This device complies with part 15 of the FCC Rules. Operation is subject to the following two conditions: (1) This device may not cause harmful interference, and (2) this device must accept any interference received, including interference that may cause undesired operation.

▼ Canada-spec. models

NOTE

This device complies with Industry Canada licence-exempt RSS standard (s). Operation is subject to the following two conditions: (1) this device may not cause interference, and (2) this device must accept any interference, including interference that may cause undesired operation of the device.

NOTE

Le présent appareil est conforme aux CNR d'Industrie Canada applicables aux appareils radio exempts de licence. L'exploitation est autorisée aux deux conditions suivantes: (1) l'appareil ne doit pas produire de brouillage, et (2) l'utilisateur de l'appareil doit accepter tout brouillage radioélectrique subi, même si le brouillage est susceptible d'en compromettre le fonctionnement.

Door locks

■ Locking and unlocking from the outside

NOTE

If you unlock the driver's door with a key (including a mechanical key) and open the door while the alarm system is armed, the alarm system is triggered and the vehicle's horn sounds. In this case, perform any of the following operations:

Models with "keyless access with push-button start system":

- Press any button on the access key (except when the access key battery is discharged).
- Turn the push-button ignition switch to the "ACC" position.

Models without "keyless access with push-button start system":

- Press any button on the remote transmitter (except when the transmitter battery is discharged).
- Insert the key into the ignition switch and turn the ignition switch to the "ON" position.

For details about the alarm system, refer to "Alarm system" 2-21.

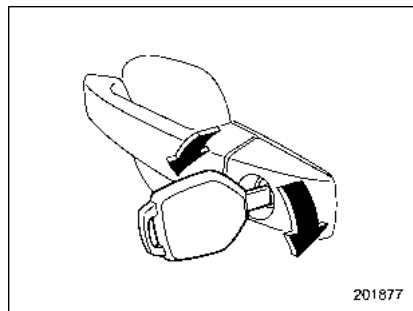

To lock the driver's door from the outside with the key, turn the key toward the front. To unlock the door, turn the key toward the rear. Pull the outside door handle to open an unlocked door.

To lock the door from outside without the key, the following methods are available.

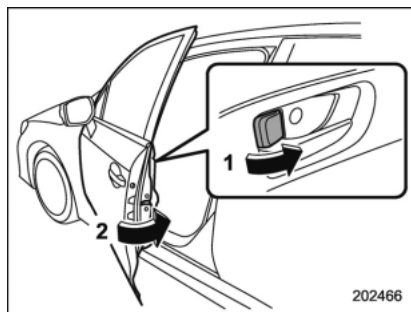

Locking using lock lever

- 1) Rotate the lock lever forward.
- 2) Close the door.

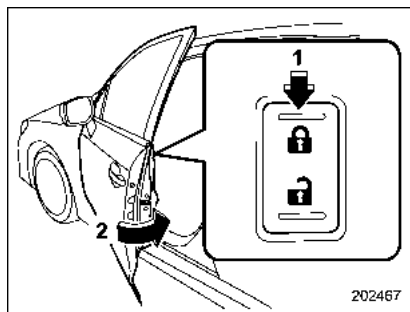

Locking using power door locking switch

- 1) Press the front side (lock side) of the power door locking switch.
- 2) Close the door.

In this case, all closed doors are locked at the same time.

Always make sure that all doors and the trunk lid are locked before leaving your vehicle.

NOTE

Make sure that you do not leave the key inside the vehicle when locking the doors from the outside without the key.

Locking and unlocking from the inside

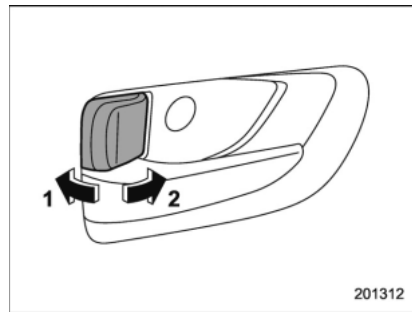

- 1) Unlock
- 2) Lock

To lock the door from the inside, rotate the lock lever forward. To unlock the door from the inside, rotate the lock lever rearward.

The red mark on the lock lever appears when the door is unlocked.

Pull the inside door handle to open an unlocked door.

Always make sure that all doors and the trunk lid are closed before starting to drive.

**WARNING**

Keep all doors locked when you drive, especially when small children are in your vehicle.

Along with the proper use of seatbelts and child restraints, locking the doors reduces the chance of being thrown out of the vehicle in an accident.

It also helps prevent passengers from falling out if a door is accidentally opened, and intruders from unexpectedly opening doors and entering your vehicle.

■ Battery drainage prevention function

If a door is not completely closed, the interior lights will remain illuminated as a result. However, several lights will be automatically turned off by the battery drainage prevention function to prevent the battery from discharging. The following interior lights will be affected by this function.

Item	Switch position	Automatically turning off
Map lights*	OFF*	Approximately 20 minutes later
Dome light	DOOR	Approximately 20 minutes later
Ignition switch light	—	Approximately 20 minutes later
Trunk light	—	Approximately 20 minutes later

*: The battery drainage prevention function affects only the map lights on models with the moonroof, and only when the map light switches are in the OFF position. The map lights on models without the moonroof do not turn off automatically, so push the light switches manually to turn them off.

The operational/non-operational setting of this function can be changed by a SUBARU dealer. Contact your SUBARU dealer to change the setting.

NOTE

- The factory setting (default setting) for this function is set as “operational”.
- When leaving the vehicle, make sure that all doors and the trunk lid are completely closed.
- The battery drainage prevention function does not operate while the

key is in the ignition switch.

Power door locking switches

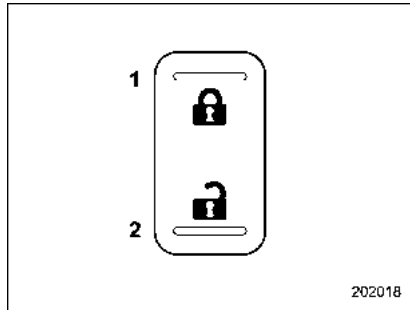

- 1) Lock
- 2) Unlock

All doors can be locked and unlocked by the power door locking switches located at the driver's side and the front passenger's side doors.

To lock the doors, push the front side of the switch.

To unlock the doors, push the rear side of the switch.

When you close the doors after you set the door locks, the doors remain locked.

NOTE

Make sure that you do not leave the key inside the vehicle before locking the doors from the outside using the power door locking switches.

■ Key lock-in prevention function

This function prevents the doors from being locked under the following conditions.

- The key is still in the ignition switch (models without "keyless access with push-button start system")
- The ignition switch is in the "ON" position (models with "keyless access with push-button start system")

This function's operational/non-operational setting can be changed by a SUBARU dealer. Contact a SUBARU dealer for details.

NOTE

- The factory setting (default setting) for this function is set as "operational".
- When leaving the vehicle, make sure you are holding the key before locking the doors.

▼ Behavior with key lock-in prevention function operational

With the driver's door open, the doors are automatically kept unlocked even if the front side of the power door locking switch is pressed.

▼ Behavior with key lock-in prevention function non-operational

- If the lock lever is turned to the front ("LOCK") position with the driver's door open and the driver's door is then closed with the lock lever in that position, the driver's door is locked.
- If the spare key is used to lock the driver's door from the outside of the vehicle, the door is locked.

Keyless access with push-button start system (if equipped)

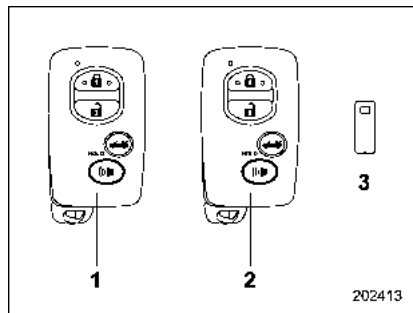

- 1) Access key (main)
- 2) Access key (sub)
- 3) Key number plate

The vehicle has two access keys and a key number plate. For details about the key number plate, refer to “Key number plate” 2-2.

The keyless access with push-button start system allows you to perform the following functions when you are carrying the access key.

- Locking and unlocking of the doors and unlocking of the trunk

- Starting and stopping the engine. For detailed information, refer to “Starting and stopping engine (models with push-button start system)” 7-12.

- Arming and disarming the alarm system. For detailed information, refer to “Alarm system” 2-21.

Locking and unlocking by the remote keyless entry system can also be controlled with the buttons on the access key. For detailed information, refer to “Remote keyless entry system” 2-17.

A mechanical key is attached to each access key. The mechanical key is used for the following operations.

- Locking and unlocking the driver’s door
- Locking and unlocking the glove box

You cannot unlock the glove box without using the mechanical key. You can keep the glove box locked when you leave your vehicle and the access key (with the mechanical key removed) at a parking facility.

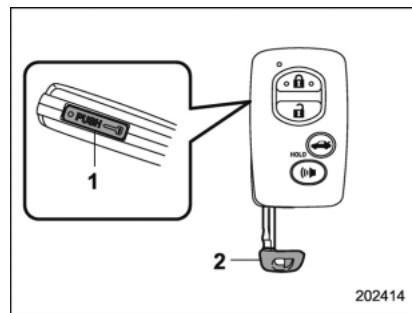

- 1) Release button
- 2) Mechanical key

While pressing the release button of the access key, take out the mechanical key.

■ Safety precautions

⚠ WARNING

If you wear an implanted pacemaker or an implanted defibrillator, stay at least 8.7 in (22 cm) away from the transmitting antennas installed on the vehicle.

The radio waves from the transmitting antennas on the vehicle could adversely affect the operation of implanted pacemakers and implanted defibrillators.

If you wear electric medical equipment other than an implanted pacemaker or an implanted defibrillator, before using the keyless access with push-button start system, refer to “Radio waves used for the keyless access with push-button start system” mentioned later, and contact the electric medical equipment manufacturer for more information. The radio waves from the transmitting antennas on the vehicle could adversely affect the operation of the electric medical equipment.

“Radio waves used for the keyless access with push-button start system”

- The keyless access with push-button start system uses radio waves of the following frequency* in addition to the radio waves used for the remote keyless entry system. The radio waves are periodically output from the antennas installed on the vehicle as shown in the following illustrations.

* Radio frequency: 134 kHz

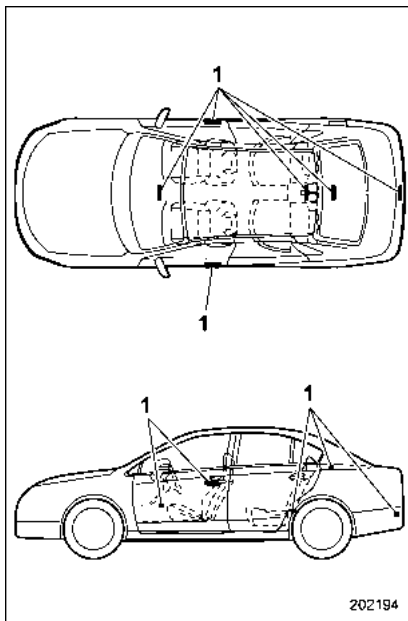

1) Antenna

CAUTION

- Never leave or store the access key inside the vehicle (e.g., on the instrumental panel, inside the

glove box, on the seat, in the door pocket or on the rear shelf) or within 6.6 ft (2 m) around the vehicle (e.g., in the garage). The access key may be locked inside the vehicle, or the battery may discharge rapidly. Note that the push-button ignition switch may not turn on in some cases depending on the location of the access key.

- The access key contains electronic components. Observe the following precautions to prevent malfunctions.
 - Although you can replace the battery of the access key yourself, it is recommended that the battery be replaced by a SUBARU dealer to avoid the risk of damage at the time of replacement.
 - Do not get the access key wet. If the access key gets wet, wipe it off immediately and let it dry completely.
 - Do not allow strong impacts to the access key.
 - Keep the access key away from magnetic sources.
 - Never leave the access key in

direct sunlight or anywhere that may become hot, such as on the dashboard. It may damage the battery or cause circuit malfunctions.

- Do not wash the access key in an ultrasonic washer.
- Do not leave the access key in humid or dusty locations. Doing so may cause malfunctions.
- Do not leave the access key near personal computers or home electric appliances. Doing so may cause the access key to malfunction, resulting in battery discharge.
- If the access key is dropped, the integrated mechanical key inside may become loose. Be careful not to lose the mechanical key.
- When you carry the access key on an airplane, do not press the button of the access key while in the airplane. When any button of the access key is pressed, radio waves are sent and may affect the operation of the airplane. When you carry the access key in a bag on an airplane, take measures to prevent the buttons

of the access key from being pressed.

NOTE

- The operational/non-operational setting for the keyless access function can be changed. For the setting procedure, refer to "Disabling keyless access function" ¶2-15. The setting can also be changed by a SUBARU dealer. For more details, contact a SUBARU dealer.
- For detailed information about the operation method for the push-button ignition switch while the keyless access function is switched to the non-operational mode, refer to "Access key – if access key does not operate properly" ¶9-16.
- The keyless access with push-button start system uses weak radio waves. The status of the access key and environmental conditions may interfere with the communication between the access key and the vehicle under the following conditions, and it may not be possible to lock or unlock the doors or start the engine.
 - When operating near a facility where strong radio waves are transmitted, such as a broadcast station

and power transmission lines

- When products that transmit radio waves are used, such as an access key or a remote transmitter key of another vehicle
- When the access key is placed near wireless communication equipment such as a cell phone
- When the access key is placed near a metallic object
- When metallic accessories are attached to the access key
- When carrying the access key with electronic appliances such as a laptop computer
- When the battery of the access key is discharged
- The access key is always communicating with the vehicle and is continuously using the battery. Although the life of the battery varies depending on the operating conditions, it is approximately 1 to 2 years. If the battery becomes fully discharged, replace it with a new one.
- If an access key is lost, it is recommended that the access key be reregistered. For reregistration of an access key, contact a SUBARU dealer.
- For a spare access key, contact a SUBARU dealer.
- Up to 7 access keys can be regis-

tered for one vehicle.

- Carefully store the key number plate supplied with the access key. It is necessary for vehicle repair.
- Do not leave the access key in the storage spaces inside the vehicle, such as the door pocket, dashboard and the rear shelf. Vibrations may damage the key or turn on the switch, possibly resulting in a lockout.
- After the vehicle battery is discharged or replaced, initialization of the steering lock system may be required to start the engine. In this case, perform the following procedure to initialize the steering lock.
 - (1) Turn the push-button ignition switch to the "OFF" position. For details, refer to "Switching power" 3-7.
 - (2) Open and close the driver's door.
 - (3) Wait for approximately 10 seconds.

When the steering is locked, the initialization is completed.

■ Locking and unlocking with "keyless access" entry function

▼ Operating ranges

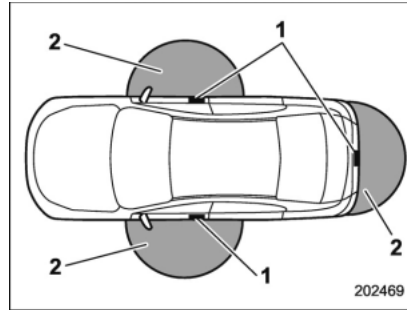

- 1) Antenna
- 2) Operating range

The operating ranges of the door locking/unlocking functions and the trunk lid unlocking function are approximately 16 to 32 in (40 to 80 cm) from the respective door handles and the trunk ornament.

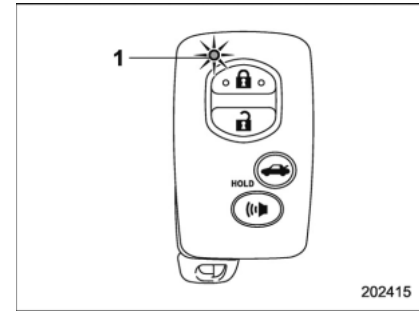

- 1) LED indicator

When the access key is within either of the operating ranges of the front doors, the LED indicator on the access key flashes. When the keyless access functions are disabled, the LED indicator does not flash unless a button on the access key is pressed.

▽ Operating range tips

- Locking by using the keyless access function can be operated only by the door lock sensor in the operating range in which the access key is detected.
- Unlocking by using the keyless access function can be operated only by the door handle in the operating range in which the access key is detected.
- If the access key is placed too close to

the vehicle body, the keyless access function may not operate properly. If they do not operate properly, repeat the operation from further away.

- If the access key is placed near the ground or in an elevated location from the ground, even if it is in the indicated operating range, the keyless access function may not operate properly.
- When the access key is within the operating range, it is possible for anyone, even someone who is not carrying the access key, to operate the keyless access function. Note that locking and unlocking can be operated only by the door handle, door lock sensor or trunk lid opener button in the operating range in which the access key is detected.
- It is not possible to lock the doors using the keyless access function when the access key is inside the vehicle. However, depending on the status of the access key and the environmental conditions, the access key may be locked inside the vehicle. Before locking, make sure that you have the access key.
- When the battery of the access key is discharged, or when operating it in a location with strong radio waves or noise (e.g., near a radio tower, power plant, broadcast station or an area where wireless equipment is used), or while talking

on a cell phone, the operating ranges may be reduced, or the keyless access function may not operate.

In such a case, perform the procedure described in "Locking and unlocking" 9-16.

- When an access key is in the operating range, if the door handle becomes wet due to exposure to a significant amount of water when the vehicle is washed or during heavy rain, the doors may be locked or unlocked.
- The keyless access function may not operate properly depending on the status of the access key and the radio wave conditions around the vehicle. In such a case, perform the procedure described in "Locking and unlocking" 9-16.

▼ How to use keyless access functions

▽ Keyless access function tips

- When you lock the doors using the keyless access function, turn the push-button ignition switch off. It is not possible to lock the doors using the keyless access function when the push-button ignition switch is on the "ACC" or "ON" position. Refer to "Switching power" 3-7.
- If the door handle is gripped or the door lock sensor is touched with a gloved hand, the door lock may not be operated.

- If the door lock sensor is touched three times or more repeatedly, the system will ignore the sensor operation.
- When performing the locking procedure too quickly, locking may not have been completed. After locking the doors, it is recommended to pull the REAR door handles to confirm that the doors have been locked.
- It is possible to lock the doors even when one of the doors is open. After performing the locking procedure, close the opened door to lock it.
- Within 3 seconds after locking the doors by using the keyless access function, it is not possible to unlock doors by using the keyless access function.
- When locking, be sure to carry the access key to prevent locking the access key in the vehicle.
- The setting of the hazard warning flasher operation can be changed by your SUBARU dealer. Contact your SUBARU dealer for details.
- The setting of the hazard warning flasher operation can also be changed by operating the multi function display. For details, refer to "Hazard warning flasher setting" 3-84.

▽ Unlocking

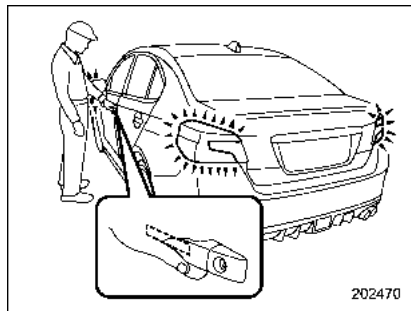

202470

Carry the access key, and grip the door handle.

- When the driver's door handle is gripped, only the driver's door will be unlocked.
- When the front passenger's door handle is gripped, all doors will be unlocked.

Also, an electronic chirp will sound twice and the hazard warning flashers will flash twice.

▽ Opening trunk

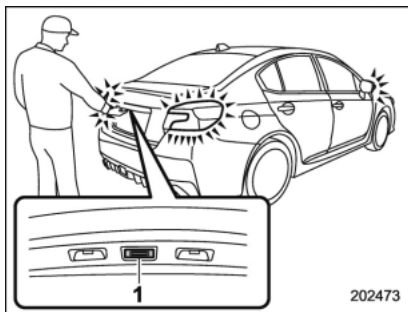

202473

- 1) Trunk lid opener button

Carry the access key, and press the trunk lid opener button. Only the trunk lid will be unlocked and opened. Also, an electronic chirp will sound twice and the hazard warning flashers will flash twice.

▽ Locking

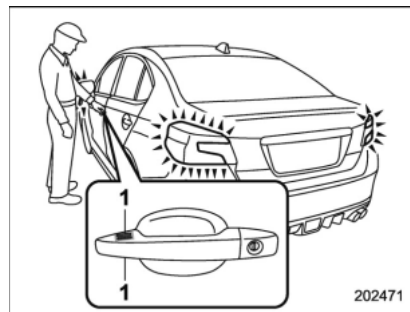

202471

- 1) Door lock sensor

Carry the access key, close all doors and the trunk lid and touch the door lock sensor. All doors will be locked. Also, an electronic chirp will sound once and the hazard warning flashers will flash once.

NOTE

After touching the door lock sensor to lock all of the doors, if you touch the door lock sensor once more to attempt the lock operation without first unlocking the doors, nothing will happen, even if the door lock sensor is touched. In this case, perform the unlocking operation once first. You can then touch the door lock sensor to lock the

doors.

▼ Power saving function

The keyless access function will be disabled in the following cases to protect the access key battery and the vehicle battery.

Case 1: When the keyless access function and the remote keyless entry system have not been used for 2 weeks or longer while all doors are locked

Case 2: When the access key has been left in the operating range for 10 minutes or longer while all doors are locked

▽ Recovery from power saving mode

When one of the following is operated, the keyless access function will be recovered.

Case 1:

- Unlock the doors by operating any procedure other than gripping the front passenger's door handle
- Lock or unlock the doors
- Open a door and then close it

Case 2:

- Unlock the doors by gripping the door handle
- Lock the doors by touching the door lock sensor

- Lock or unlock the doors by using the remote keyless entry system
- Lock or unlock the doors by using the power door locking switch
- Open either of the front doors

▼ Door unlock selection function

The door unlock selection function makes it possible to unlock the driver's door without unlocking any other doors. You can change the setting for the driver's door.

Operational: Only the driver's door will be unlocked.

Non-operational: All doors will be unlocked.

For the factory setting (default setting), refer to "Function settings" 3-22.

NOTE

The setting can be changed by your SUBARU dealer. Contact your SUBARU dealer for details. Also, the setting can be changed by operating the multi function display. For details, refer to "Keyless access setting (models with "keyless access with push-button start system")" 3-88.

■ Selecting audible signal operation

Using an electronic chirp, the system will give you an audible signal when the doors lock and unlock. If desired, you may change the volume of the audible signal or turn it off.

NOTE

- **The on/off setting of the audible signal can be changed by operating the multi function display. For details, refer to "Audible signal setting" 3-83.**
- **The volume of the audible signal can be changed at SUBARU dealers. For more details, contact a SUBARU dealer.**

■ Warning chimes and warning indicator

The keyless access with push-button start system sounds a warning chime and flashes the access key warning indicator on the combination meter in order to minimize improper operations and help protect your vehicle from theft.

For details, refer to "Warning chimes and warning indicator of the keyless access with push-button start system" 3-26.

■ Disabling keyless access function

When the vehicle is not going to be used for a long time, or when you choose not to use the keyless access function, the keyless access function can be disabled.

NOTE

- The locking and unlocking function by the remote keyless entry system is not disabled.
- The setting can also be changed at SUBARU dealers. For more details, contact a SUBARU dealer.
- To start the engine while the functions are disabled, perform the procedure described in “Starting engine” 9-17.
- We recommend that you disable the keyless access functions under the following conditions.
 - When the vehicle is not going to be used for an extended period of time
 - When the keyless access functions are not going to be used
 - When the access key needs to be stored inside or near the vehicle

▼ Disabling functions

1. Sit in the driver's seat, and close the door.

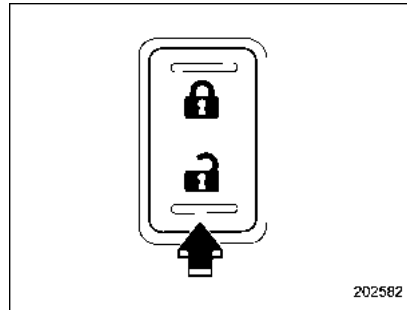

2. Push the rear side (unlock side) of the power door locking switch.
3. Within 5 seconds after step 2 is performed, open the driver's door.
4. Within 5 seconds after step 3 is performed, push the rear side (unlock side) of the power door locking switch twice while the door is open.
5. Within 30 seconds after step 4 is performed, close and open the driver's door twice.
6. Within 30 seconds after step 5 is performed, push the rear side (unlock side) of the power door locking switch twice while the door is open.

7. Within 30 seconds after step 6 is performed, close and open the driver's door once.
8. Within 5 seconds after step 7 is performed, close the door. A chirp sound will be heard, and the functions will be disabled.

NOTE

In steps 4 and 6, press the power door locking switch slowly. If the switch is pressed quickly, the functions may not be disabled.

▼ Enabling functions

When the procedure to disable the functions is performed again, the functions are enabled.

A chirp sound will be heard once.

■ When access key does not operate properly

Refer to “Access key – if access key does not operate properly” 9-16.

■ Replacing battery of access key

Refer to “Replacing access key battery” 11-49.

■ Replacing access key

Access keys can be replaced at SUBARU dealers. For more details, contact a SUBARU dealer.

■ Certification for keyless access with push-button start system

▼ U.S.-spec. models

FCC ID: HYQ13CZZ

FCC ID: HYQ14ACX

FCC ID: Y8PSSPIMB02

FCC ID: Y8PSSPLF02



CAUTION

FCC WARNING

Changes or modifications not expressly approved by the party responsible for compliance could void the user's authority to operate the equipment.

NOTE

This device complies with part 15 of the FCC Rules. Operation is subject to the following two conditions: (1) This device may not cause harmful interference, and (2) this device must accept any interference received, including

interference that may cause undesired operation.

▼ Canada-spec. models

NOTE

This device complies with Industry Canada licence-exempt RSS standard (s). Operation is subject to the following two conditions: (1) this device may not cause interference, and (2) this device must accept any interference, including interference that may cause undesired operation of the device.

NOTE

Le présent appareil est conforme aux CNR d'Industrie Canada applicables aux appareils radio exempts de licence. L'exploitation est autorisée aux deux conditions suivantes: (1) l'appareil ne doit pas produire de brouillage, et (2) l'utilisateur de l'appareil doit accepter tout brouillage radioélectrique subi, même si le brouillage est susceptible d'en compromettre le fonctionnement.

▼ Mexico-spec. models

COFETEL

RLVDE1408-0265

14ACX

DENSO

NOTE

Este equipo opera a título secundario, consecuentemente, debe aceptar interferencias perjudiciales incluyendo equipos de la misma clase y puede no causar interferencias a sistemas operando a título primario.

Remote keyless entry system



CAUTION

- Do not expose the remote transmitter to severe shocks, such as those experienced as a result of dropping or throwing.
- Do not take the remote transmitter apart except when replacing the battery.
- Do not get the remote transmitter wet. If it gets wet, wipe it dry with a cloth immediately.
- When you carry the remote transmitter on an airplane, do not press the button of the remote transmitter while in the airplane. When any button of the remote transmitter is pressed, radio waves are sent and may affect the operation of the airplane. When you carry the remote transmitter in a bag on an airplane, take measures to prevent the buttons of the remote transmitter from being pressed.
- **FCC WARNING**
Changes or modifications not expressly approved by the party

responsible for compliance could void the user's authority to operate the equipment.

FCC ID: CWTWB1U811

FCC ID: CWTWBU766

NOTE

This device complies with Part 15 of FCC Rules and Industry Canada licence-exempt RSS standard(s). Operation is subject to the following two conditions: (1) this device may not cause interference, and (2) this device must accept any interference, including interference that may cause undesired operation of this device.

NOTE

Le présent appareil est conforme aux la partie 15 des règles de la FCC et CNR d'Industrie Canada applicables aux appareils radio exempts de licence. L'exploitation est autorisée aux deux conditions suivantes: (1) l'appareil ne doit pas produire de brouillage, et (2) l'utilisateur de l'appareil doit accepter tout brouillage radioélectrique subi, même si le brouillage est susceptible d'en compromettre le fonctionnement.

For models with "keyless access with push-button start system", the access

key is used as the transmitter for the remote keyless entry system. For models without "keyless access with push-button start system", the transmitter for the remote keyless entry system is located inside the key head.

The remote keyless entry system has the following functions.

- Locking and unlocking the doors without a key
- Opening the trunk without a key
- Sounding a panic alarm
- Arming and disarming the alarm system. For detailed information, refer to "Alarm system" 2-21.

The operable distance of the remote keyless entry system is approximately 30 feet (10 meters). However, this distance will vary depending on environmental conditions. The system's operable distance will be shorter in areas near a facility or electronic equipment emitting strong radio waves such as a power plant, broadcast station, TV tower, or remote controller of home electronic appliances.

NOTE

- For models with "keyless access with push-button start system", the remote keyless entry system will not be activated when the push-button

ignition switch is in any position other than the “OFF” position.

● For models without “keyless access with push-button start system”, the remote keyless entry system will not be activated when the key is inserted in the ignition switch.

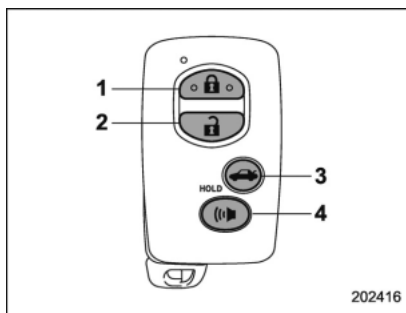

Access key

- 1) Lock/arm button
- 2) Unlock/disarm button
- 3) Trunk lid unlock button
- 4) PANIC button

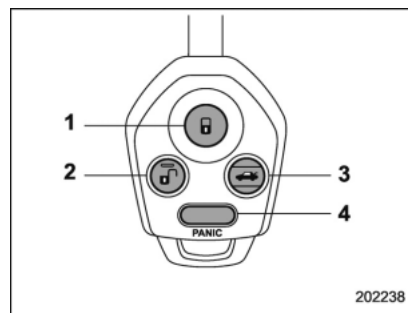

Transmitter

- 1) Lock/arm button
- 2) Unlock/disarm button
- 3) Trunk lid unlock button
- 4) PANIC button

NOTE

The hazard warning flashers will flash once or twice when the transmitter button is pressed in the following cases.

- When locking the doors
- When unlocking the doors
- When unlocking the trunk lid

Operation of the hazard warning flashers in the above cases can be set to “On” or “Off” by a SUBARU dealer. Consult your SUBARU dealer for de-

tails. Also, the setting can be changed using the display. For details, refer to “Hazard warning flasher setting” 3-84.

■ Locking the doors

Press the lock/arm button to lock all doors. An electronic chirp will sound once and the hazard warning flashers will flash once.

If any of the doors or the trunk lid is not fully closed, an electronic chirp will sound five times and the hazard warning flashers will flash five times to alert you that the doors (or the trunk lid) are not properly closed. When you close the door, it will automatically lock and then an electronic chirp will sound once and the hazard warning flashers will flash once.

■ Unlocking the doors

Press the unlock/disarm button to unlock the driver's door. An electronic chirp will sound twice and the hazard warning flashers will flash twice. To unlock all doors, briefly press the unlock/disarm button a second time within 5 seconds.

NOTE

If the interval between the first and second presses of the unlock/disarm button (for unlocking of all of the doors) is extremely short, the system may not respond.

■ Opening the trunk lid

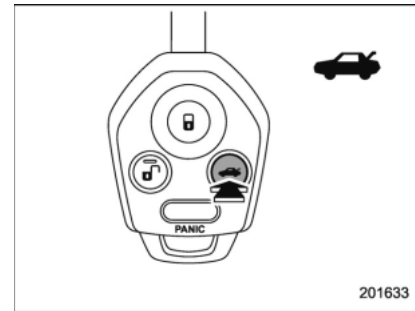
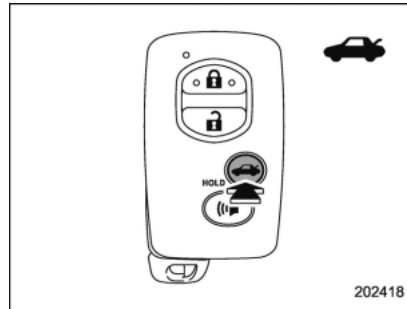

The trunk lid opens when the “” button is pressed continuously for at least 2 seconds. An electronic chirp will sound twice and the turn signal lights will flash twice.

■ Vehicle finder function

Use this function to find your vehicle parked among many vehicles in a large parking lot. Provided you are within 30 feet (10 meters) of the vehicle, pressing the lock/arm button three times in a 5-second period will cause your vehicle's horn to sound once and its hazard warning flashers to flash three times.

NOTE

If the interval between presses is too short when you press the lock/arm

button three times, the system may not respond to the signals from the access key/remote transmitter.

■ Sounding a panic alarm

To activate the alarm, press the “PANIC” button once.

The horn will sound and the hazard warning flashers will flash.

To deactivate the panic alarm, press any button on the access key/remote transmitter. Unless a button on the access key/remote transmitter is pressed, the alarm will be deactivated after approximately 30 seconds.

■ Selecting audible signal operation (models without “keyless access with push-button start system”)

Using an electronic chirp, the system will give you an audible signal when the doors lock and unlock. If desired, you may turn the audible signal off.

Perform the following steps to deactivate the audible signal. You can also use the same steps to restore the function.

1. Sit in the driver’s seat and shut all doors and the trunk.

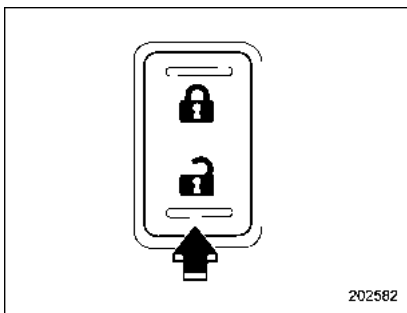

2. Hold down the REAR (UNLOCK) side of the power door locking switch.

3. While holding down the REAR (UNLOCK) side of the power door locking switch, pull the key out and re-insert it into the ignition switch at least 6 times within 10 seconds after Step 2.

4. Open and close the driver’s door once within 10 seconds after Step 3.

5. The hazard warning flashers flash 3 times to indicate completion of the setting.

You may have the above settings done by your SUBARU dealer. Also, the setting can be changed using the multi function display. For details, refer to “Audible signal setting” 3-83.

You may also change the volume of the audible signal. For more details, contact a

SUBARU dealer.

■ Replacing the battery

Refer to “Battery replacement” 11-49.

■ Replacing lost transmitters

If you lose a transmitter or want to purchase additional transmitters (up to four can be programmed), your transmitters should be reprogrammed for security reasons. For details, contact your SUBARU dealer and have the transmitters programmed into the remote keyless entry system.

■ Welcome lighting (if equipped)

The welcome lighting turns on the headlights, interior lights, etc. for smooth approaching to or exiting from the vehicle at night or in a dark place.

NOTE

- For the operation of the interior lights, refer to “Interior lights” 6-2.
- The factory setting (default setting) of the operation duration of the headlights and the exterior lights is 30 seconds for both approaching and exiting. This setting can be changed to OFF (no operation), 30 seconds, 60 seconds, or 90 seconds, respectively

for approaching and exiting at SUBARU dealers. For more details, contact a SUBARU dealer.

▼ Approaching

When it is dark and the light control switch is in the "AUTO" position, if the doors are unlocked using the unlock button on the transmitter, the headlight low beams and some exterior lights will illuminate. The interior lights will also illuminate if the dome light switch is in the "DOOR" position.

The headlight low beams and the exterior lights will illuminate for 30 seconds.

NOTE

If the doors are locked using the lock button on the transmitter or the lock sensor on the door handle, the headlights and exterior lights will turn off.

▼ Exiting

When the light control switch is in the "AUTO" position and the headlight indicator light is on, if the ignition switch is turned off or the key is removed from the ignition switch, the headlight low beams and some exterior lights will continue illuminating.

The headlights and exterior lights will turn off under either of the following conditions.

- 30 seconds have elapsed since the driver's door was opened and closed.
- The lock button on the transmitter or the lock sensor on the door handle is operated two times successively.

NOTE

- **If the light control switch is set to a position other than "AUTO" position, the headlights and the exterior lights will turn off.**
- **When exiting from the vehicle, the headlights and exterior lights will turn off if the driver's door is not opened and closed within 3 minutes from turning on of the welcome lighting.**

Alarm system

The alarm system helps to protect your vehicle and valuables from theft. The horn sounds and the hazard warning flashers flash if someone attempts to break into your vehicle.

For models with "keyless access with push-button start system":

The system can be armed and disarmed with the keyless access function or access key.

The system will not be activated when the push-button ignition switch is in the "ACC" or "ON" position.

For models without "keyless access with push-button start system":

The system can be armed and disarmed with the remote transmitter.

The system will not be activated when the key is inserted into the ignition switch.

Your vehicle's alarm system has been set for activation at the time of shipment from the factory. You can set the system for deactivation yourself or have it done by your SUBARU dealer.

■ System operation

The alarm system will give the following alarms when triggered.

- The vehicle's horn will sound for 30 seconds.
- The hazard warning flashers will flash for 30 seconds.

If any of the doors or the trunk lid remains open after the 30-second period, the horn will continue to sound for a maximum of 3 minutes. If the door or the trunk lid is closed while the horn is sounding, the horn will stop sounding with a delay of up to 30 seconds.

The alarm is triggered by:

- Opening any of the doors or the trunk lid
- Physical impact to the vehicle, such as forced entry (only models with shock sensors (dealer option))

NOTE

The alarm system can be set to trigger the illumination of the following interior lights.

- **Map lights (for models with moonroof)**
- **Dome light (illuminates only when the dome light switch is in the "DOOR" position)**

The notifications regarding the map lights (for models with moonroof) and dome light are deactivated as the factory setting. A SUBARU dealer can activate the system. Contact your SUBARU dealer for details.

■ Activating and deactivating the alarm system

To change the setting of your vehicle's alarm system for activation or deactivation, do the following.

1. Disarm the alarm system. Refer to "Disarming the system"  2-25.
2. Sit in the driver's seat and shut all doors and the trunk lid.
3. Turn the ignition switch to the "ON" position.
4. Hold down the REAR (UNLOCK) side of the driver's power door locking switch, open the driver's door within the following 1 second, and wait 10 seconds without releasing the switch. The setting will then be changed as follows.

If the system was previously activated:

The odometer/trip meter screen displays "AL OF" and the horn sounds twice, indicating that the system is now deactivated.

If the system was previously deactivated:

The odometer/trip meter screen displays "AL ON" and the horn sounds once, indicating that the system is now activated.

NOTE

You may have the above setting change done by your SUBARU dealer.

■ If you have accidentally triggered the alarm system

▼ To stop the alarm

Perform any of the following operations.

- Press any button on the access key/remote transmitter.
- Turn the ignition switch to the "ON" position (models without "keyless access with push-button start system").
- Turn the push-button ignition to the "ACC" position (models with "keyless access with push-button start system").

NOTE

Only registered keys will stop the alarm. If the key is not registered, the alarm will not stop.

■ Arming the system

NOTE

- The system can be armed even if the engine hood, the windows and/or moonroof are open. Always make sure that they are fully closed before arming the system.
- When arming the system, if any of the doors or the trunk lid is not fully closed, an electronic chirp sounds five times, the hazard warning flashers flash five times to alert you that the doors (or the trunk lid) are not properly closed. When you close the door, doors will automatically lock and the system will automatically arm in 30 seconds.
- The 30-second standby time can be eliminated if you prefer. Have it performed by your SUBARU dealer.
- If you open the trunk using the remote transmitter's "🚗" button in the surveillance state (or the standby state), the system will be temporarily placed in a standby state. The system will go back to the surveillance state in 30 seconds upon locking the trunk.
- The system is in the standby state for a 30-second period before arming the system. The security indicator light will flash at short intervals during this period.
- If any of the following actions is

done during the standby period, the system will not switch to the surveillance state.

- Doors (including the trunk lid) are unlocked using the access key/remote transmitter.
- Doors (including the trunk lid) are unlocked using the keyless access function (models with "keyless access with push-button start system").
- Any door (including the trunk lid) is opened.
- The ignition switch is turned to the "ON" position (models without "keyless access with push-button start system").
- Push-button ignition switch is turned to the "ACC" position (models with "keyless access with push-button start system").

▼ To arm the system using the access key/remote transmitter

1. Close all windows and the moonroof (if equipped).
2. Remove the key from the ignition switch (models without "keyless access with push-button start system")/turn the push-button ignition switch to the "OFF" position (models with "keyless access with push-button start system").

3. Open the doors and get out of the vehicle.
4. Make sure that the engine hood is locked.
5. Close all doors and the trunk lid.

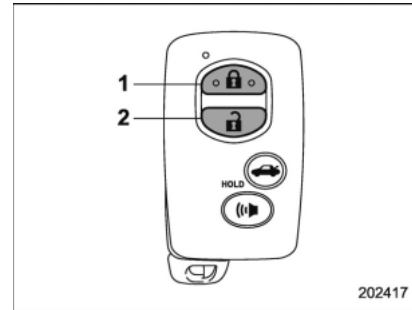

Access key

- 1) Arm button: Press to arm the system
- 2) Disarm button: Press to disarm the system

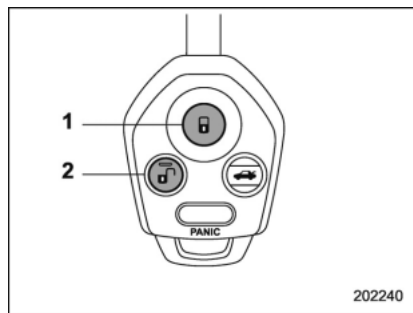

Transmitter

- 1) Arm button: Press to arm the system
- 2) Disarm button: Press to disarm the system

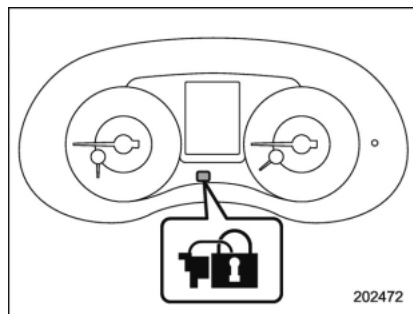

6. Briefly press the arm button (for less than 2 seconds). All doors will lock, an

electronic chirp will sound once, the hazard warning flashers will flash once, and the security indicator light will start flashing rapidly. After rapid flashing for 30 seconds (standby time), the indicator light will then flash slowly (twice approximately every 2 seconds), indicating that the system has been armed for surveillance.

▼ To arm the system using power door locking switches

1. Close all windows.
2. Remove the key from the ignition switch (models without "keyless access with push-button start system")/turn the push-button ignition switch to the "OFF" position (models with "keyless access with push-button start system").
3. Open the doors and get out of the vehicle.
4. Make sure that the engine hood is locked.
5. Close the doors and the trunk lid but leave only the driver's door or the front passenger's door open.

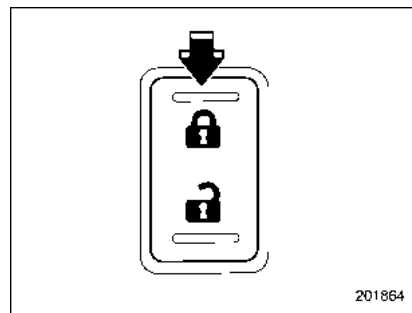

6. Press the front side ("LOCK" side) of the power door locking switch to set the door locks.
7. Close the door. An electronic chirp will sound once, the hazard warning flashers will flash once and the security indicator light will start flashing rapidly. After rapid flashing for 30 seconds (standby time), the indicator light will then flash slowly (twice approximately every 2 seconds), indicating that the system has been armed for surveillance.

▼ **To arm the system using the keyless access function (if equipped)**

1. Close all windows and the moonroof (if equipped)
2. Turn the push-button ignition switch to the "OFF" position.
3. Open the doors and get out of the vehicle.
4. Make sure that the engine hood is locked.
5. Close all doors and the trunk lid.

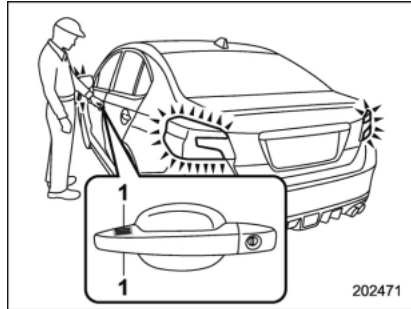

1) Door lock sensor

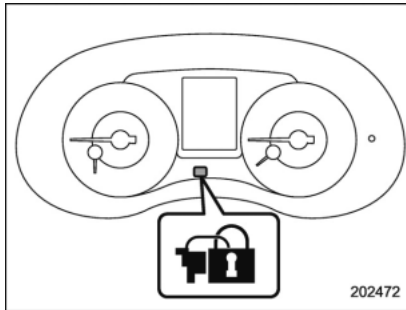

Security indicator light

6. Carry the access key and touch the door lock sensor. All doors will lock, an electronic chirp will sound once, the hazard warning flashers will flash once, and the security indicator light will start flashing rapidly. After rapid flashing for 30 seconds (standby time), the security indicator light will then flash slowly (twice approximately every 2 seconds), indicating that the system has been armed for surveillance.

■ **Disarming the system**

Perform either of the following procedures.

- Briefly press the disarm button (for less than 2 seconds) on the access key/remote transmitter.

- Carry the access key and grip the front door handle (models with "keyless access with push-button start system").

The flashing of the security indicator light will then change slowly (once approximately every 3 seconds from twice approximately every 2 seconds), indicating that the alarm system has been disarmed.

▼ **Emergency disarming**

If you cannot disarm the system using the access key/transmitter (i.e. the transmitter is lost, broken or the transmitter battery is too weak), you can disarm the system without using the access key/remote transmitter.

The system can be disarmed if you turn the ignition switch from the "LOCK"/"OFF" to the "ON" position with a registered key/access key.

NOTE

For models with "keyless access with push-button start system", if the access key battery is discharged, perform the procedure described in "Switching power" 9-16. In such a case, replace the battery immediately. Refer to "Replacing access key battery" 11-49.

■ Valet mode

When you choose the valet mode, the alarm system does not operate. In valet mode, the access key/remote transmitter is used only for locking and unlocking the doors and for panic activation.

To enter the valet mode, change the setting of your vehicle's alarm system for deactivation mode. Refer to "Activating and deactivating the alarm system" 2-22. The security indicator light will continue to flash once every 3 seconds indicating that the system is in the valet mode.

To exit valet mode, change the setting of your vehicle's alarm system for activation mode. Refer to "Activating and deactivating the alarm system" 2-22.

■ Passive arming (models without "keyless access with push-button start system")

When passive arming mode has been programmed by the dealer, arming of the system is automatically accomplished without using the remote transmitter. Note that in this mode, DOORS MUST BE MANUALLY LOCKED.

▼ To enter the passive mode

If you wish to program the passive arming mode, have it done by your SUBARU dealer.

▼ Arming the system

CAUTION

In passive mode, the system will automatically activate the alarm but WILL NOT automatically lock the doors. In order to lock the doors you must either lock them as indicated in step 4 below or with the key once they have been closed. Failure to lock the doors manually will result in a higher security risk.

1. Turn the ignition switch to the "ON" position.

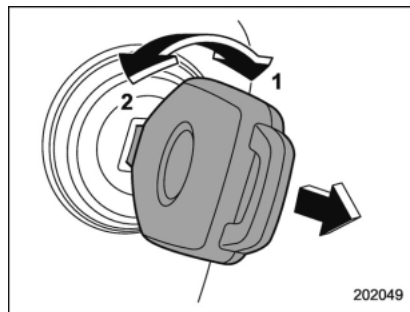

- 1) ON
- 2) LOCK

2. Turn the ignition switch from "ON" to "LOCK" position and remove the key from the ignition switch.

3. Open the doors and get out of the vehicle.

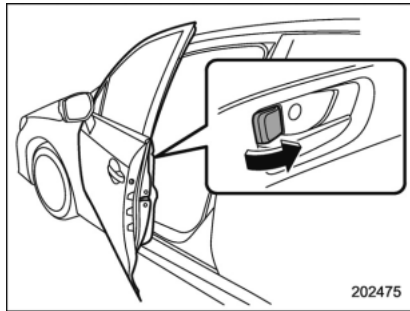

4. Before closing the doors, lock all doors with the inside door lock levers.
5. Close the doors. The system will automatically arm after 1 minute.

In the passive mode, the system can also be armed with the remote transmitter or with the power door locking switches. If the remote transmitter or power door locking switch is used to lock the vehicle, arming will take place immediately regardless of whether or not the passive mode has been selected.

▼ Disarming the system

To disarm the system, briefly press the disarm button on the remote transmitter.

■ Tripped sensor identification

The security indicator light flashes when the alarm system has been triggered. Also, the number of flashes indicates the location of unauthorized intrusion or the severity of impact on the vehicle.

When the ignition switch is turned to the "ON" position, the indicator light will light for 1 second and then flash as follows.

- When a door was opened: 5 times
- When the trunk was opened: 4 times
- When a strong impact or multiple impacts were sensed: twice (only models with shock sensors (dealer option))
- When a light impact was sensed: once (only models with shock sensors (dealer option))

NOTE

Any of the above indicator light flashings will recur each time the ignition switch is turned to the "ON" position. Rearming the alarm system cancels the flashing.

■ Shock sensors (dealer option)

The shock sensors trigger the alarm system when they sense impacts applied to the vehicle and when any of their electric wires are cut. The alarm system causes the horn to sound and the hazard warning flashers to flash for a short time when the sensed impact is weak, but it warns of a strong impact or multiple impacts by sounding the horn and flashing the hazard warning flashers, both lasting approximately 30 seconds.

If you desire, your SUBARU dealer can connect them and set them for activation or deactivation.

NOTE

- The shock sensors are not always able to sense impacts caused by breaking in, and cannot sense an impact that does not cause vibration (such as breaking the glass using a rescue hammer).
- The shock sensors may sense vibration as indicated in the following examples and trigger the alarm system. Select the settings of the alarm system and shock sensors appropriately depending on where you usually park your vehicle.

Examples:

- Vibration from a construction site
- Vibration in a multistory car park
- Vibration from trains
- You can have the sensitivity of the shock sensors adjusted to your preference by your SUBARU dealer.

Child safety locks

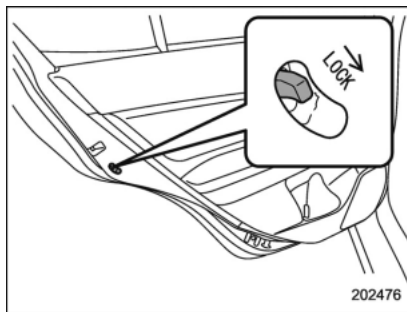

Each rear door has a child safety lock. When the child safety lock lever is in the lock position, the door cannot be opened from inside. The door can only be opened from the outside.



WARNING

Always turn the child safety locks to the "LOCK" position when children sit in the rear seat. Serious injury could result if a child accidentally opens the door and falls out.

Windows



WARNING

To avoid serious personal injury caused by accidental, child's mischief, or improper operation, the driver is responsible for obeying the following instructions without exception.

- When operating the power windows, be extremely careful to prevent anyone's fingers, arms, neck, head or other objects from being caught in the window.
- Always lock the passengers' windows using the lock switch when children are riding in the vehicle.
- Before leaving the vehicle, always remove the key from the ignition switch for safety (models without "keyless access with push-button start system") and never allow an unattended child to remain in the vehicle. Failure to follow this procedure could result in injury to a child operating the power window.

The power windows operate only when the ignition switch is in the "ON" position.

■ Power window operation by driver

▼ Driver's side power window switches

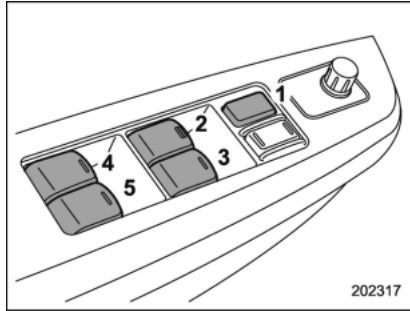

- 1) Lock switch
- 2) For driver's window (with one-touch auto up and down feature)
- 3) For front passenger's window
- 4) For rear left window
- 5) For rear right window

All door windows can be controlled by the power window switch cluster at the driver side door.

▼ Operating the driver's window

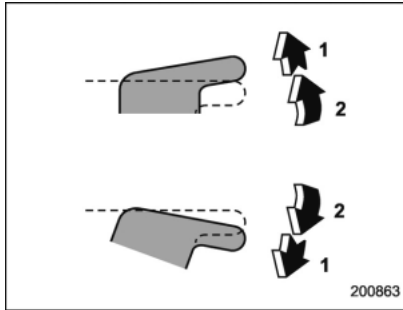

- 1) Automatically open/close
- 2) Open/close

To open:

Push the switch down lightly and hold it. The window will open as long as the switch is held.

This switch also has a one-touch auto down feature that allows the window to be opened fully without holding the switch.

Push the switch down until it clicks and release it, and the window will fully open. To stop the window halfway, pull the switch up lightly.

To close:

Pull the switch up lightly and hold it. The window will close as long as the switch is held.

This switch also has a one-touch auto up feature that allows the window to be closed fully without holding the switch.

Pull the switch up until it clicks and release it, and the window will fully close. To stop the window halfway, push the switch down lightly.

NOTE

- If the vehicle's battery is disconnected due to situations such as battery or fuse replacement, the one-touch auto up/down function is deactivated. Initialize the power window to reactivate the one-touch auto up/down function. Refer to "Initialization of power window" 2-32.

- When the following operations are performed, the power window breaker will operate and it may not be possible to open or close the window.

- After the driver's side window is fully closed or fully opened, the switch continues to be operated in the same direction for a few seconds.

- After the windows for three or more seats are fully closed or fully opened, each switch continues to be operated in the same direction simultaneously for a few seconds.

In this case, after the breaker recovers,

– CONTINUED –

be sure to initialize the power windows. If they are not initialized, the one-touch auto up/down function will not operate. Refer to “Initialization of power window” 2-32.

▼ Anti-entrapment function

 CAUTION

- Never attempt to test this function using fingers, hands or other parts of your body.
- The anti-entrapment function may not operate properly if some object gets trapped just before the window fully closes.

NOTE

- If a window detects an impact similar to that caused by trapping an object (for example, when the vehicle encounters a deep pothole), the anti-entrapment function may operate.
- The window cannot be operated for a few seconds after the anti-entrapment function operates.
- If the vehicle’s battery is disconnected due to situations such as battery or fuse replacement, the anti-entrapment function is deactivated. Initialize the power window to reacti-

vate the anti-entrapment function. Refer to “Initialization of power window” 2-32.

While closing the driver’s window automatically, if the window senses a substantial enough object trapped between the window and the window frame, it automatically moves down slightly and stops.

▼ Operating the passengers’ windows

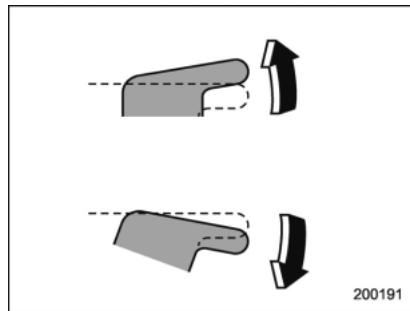

To open:

Push the appropriate switch down and hold it until the window reaches the desired position.

To close:

Pull the switch up and hold it until the window reaches the desired position.

▼ Locking the passengers' windows

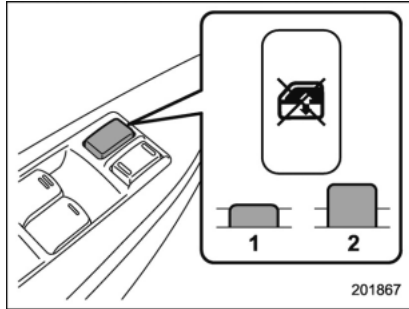

- 1) Lock
- 2) Unlock

To lock:

Press the lock switch. When the lock switch is in the lock position, the passengers' windows cannot be opened or closed.

To unlock:

Press the lock switch again.

■ Power window operation by passengers

▼ Passenger's side power window switches

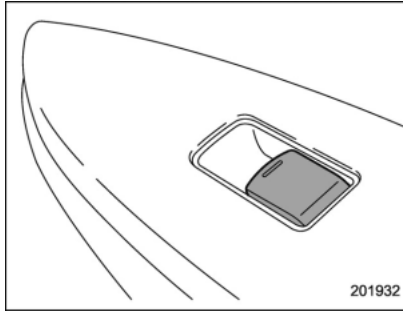

Each passenger window can be controlled by the power window switch located on the door.

▼ Operating the windows

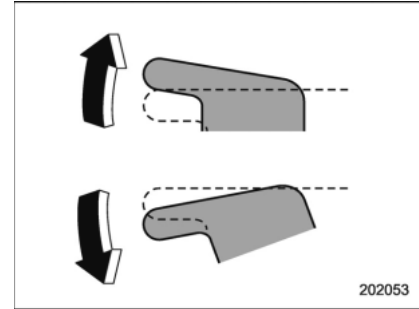

To open:

Press the switch down and hold it until the window reaches the desired position.

To close:

Pull the switch up and hold it until the window reaches the desired position.

When the lock switch on the power window switch cluster, located on the driver's side door, is in the lock position, the passengers' windows cannot be operated with the passengers' switches.

■ Initialization of power window

If the vehicle's battery is disconnected due to situations such as battery or fuse replacement, the following functions will be deactivated.

- One-touch auto up/down function
- Anti-entrapment function

Initialize the power window using the following procedure to reactivate these functions.

1. Close the driver's door.
2. Turn the ignition switch to the "ON" position.
3. Open the driver's side window halfway by pushing down the power window switch.
4. Pull up the power window switch and close the window completely. Continue pulling up the switch for approximately 1 second after the window is closed completely.
5. Open the driver's side window completely by fully pushing down the power windows switch.

Trunk lid



WARNING

- **To prevent dangerous exhaust gas from entering the vehicle, always keep the trunk lid closed while driving.**
- **Help prevent children, adults or animals from locking themselves in the trunk. On hot or sunny days, the temperature in the trunk could quickly become high enough to cause death or serious heat-related injuries including brain damage to anyone locked inside, particularly for small children.**
- **When leaving the vehicle, close all windows and lock all doors. Also make certain that the trunk is closed.**

■ To open and close the trunk lid from outside

The trunk lid can be opened using the keyless access function or remote keyless entry system. For details, refer to the following section.

- For models with "keyless access with

push-button start system", refer to "Opening trunk" 2-13.

- For models without "keyless access with push-button start system", refer to "Opening the trunk lid" 2-19.

To close the trunk lid, lightly press the trunk lid down until the latch engages.

NOTE

Do not leave your valuables in the trunk when you leave your vehicle.

■ To open the trunk lid from inside

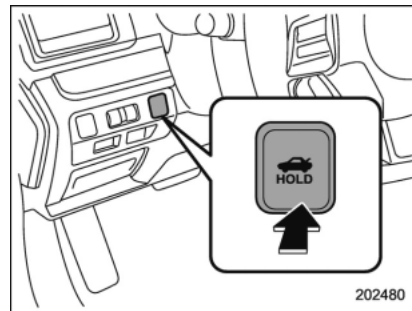

Press the trunk lid opener switch for more than 1 second.

NOTE

The trunk lid will not open when the select lever is in a position other than the "P" position (CVT models) or the vehicle is moving.

■ Internal trunk lid release handle

The internal trunk lid release handle is a device designed to open the trunk lid from inside the trunk. In the event children or adults become locked inside the trunk, the handle allows them to open the lid. The handle is located on the inside of the trunk lid.

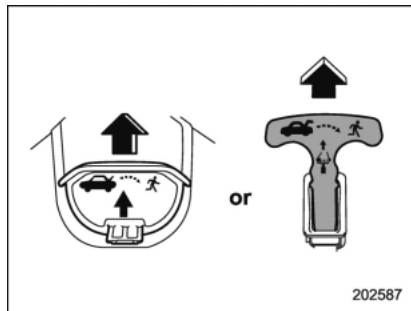

To open the trunk lid from inside the trunk, pull the yellow handle as indicated by the arrow on the handle. This operation

unlocks the trunk lid. Then, push up the lid.

The handle is made of material that remains luminescent for approximately an hour in the dark trunk space after it is exposed to ambient light even for a short time.

⚠ WARNING

Never allow any child to get in the trunk and play with the release handle. If the driver starts the vehicle without knowing that a child is inside the trunk and the child opens the lid using the release handle, the child could fall out and be killed or seriously injured.

⚠ CAUTION

- Do not close the lid while gripping the release handle. The handle may be damaged.
- Do not use the handle as a hook to fasten straps or ropes to secure your cargo in the trunk. Such use may result in damage of the handle.
- Load the trunk so that cargo cannot strike the release handle.

If the cargo hits the handle while the vehicle is being driven, the handle may be pulled and the trunk lid may open. That may cause cargo to fall out of the trunk, which could create a traffic safety hazard.

▼ Inspection

Perform the following steps at least twice a year to check the release handle for correct operation.

1. Open the trunk lid.

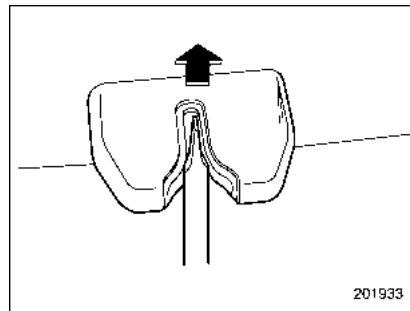

2. Use a flat-head screwdriver with a thin blade. Slide the flat-head screwdriver blade from the slit aperture of the lock assembly fully to the end until you hear a click.

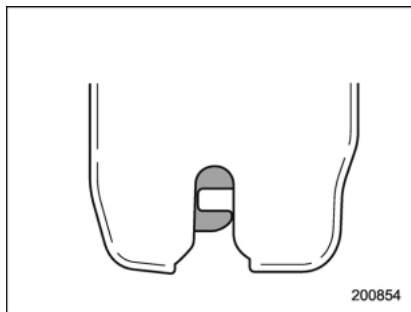

This places the latch in the locked position.

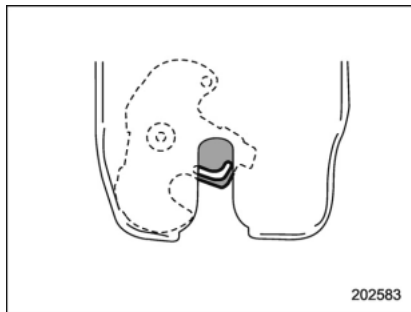

3. Move the release handle, from outside the vehicle, in the direction of the arrow to check if the latch is released.

If the latch is not released, contact your SUBARU dealer.

In that case, use the key to release the latch, then close the trunk lid.

Also, if the movement of the release handle feels restricted or not entirely smooth during operation, or the handle and/or handle base is cracked, contact your SUBARU dealer.

Moonroof (if equipped)

WARNING

Never let anyone's hands, arms, head or any objects protrude from the moonroof. A person could be seriously injured if the vehicle stops suddenly or turns sharply or if the vehicle is involved in an accident.

To avoid serious personal injury caused by accidental, child's mischief, or improper operation, the driver is responsible for obeying the following instructions without exception.

- Before closing the moonroof, make sure that no one's hands, arms, head or other objects will be accidentally caught in the moonroof.
- Before leaving the vehicle, always remove the key from the ignition switch for safety (models without "keyless access with push-button start system") and never allow an unattended child to remain in the vehicle. Failure to follow this procedure could result in injury to a child operating the moonroof.

- Never try to check the anti-entrapment function by deliberately placing part of your body in the moonroof.

CAUTION

- Do not sit on the edge of the open moonroof.
- Do not operate the moonroof if falling snow or extremely cold conditions have caused it to freeze shut.
- The anti-entrapment function does not operate when the moonroof is being tilted down. Be sure to confirm that it is safe to do so before tilting the moonroof down.

The moonroof has both tilting and sliding functions.

The moonroof operates only when the ignition switch is in the "ON" position.

■ Moonroof switches

▼ Tilting moonroof

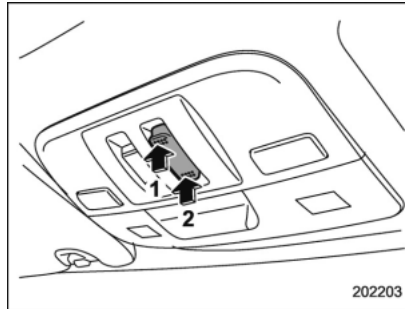

- 1) Raise
- 2) Lower

The tilting function is activated only when the moonroof is fully closed.

To raise:

Press and hold the rear side of the "UP/DOWN" switch for a short time. The moonroof raises completely.

To lower:

Press and hold the front side of the "UP/DOWN" switch until the preferred position has reached.

Release the switch after the moonroof has been raised or has been lowered com-

pletely. Pressing the switch continuously may cause damage to the moonroof.

▼ Sliding moonroof

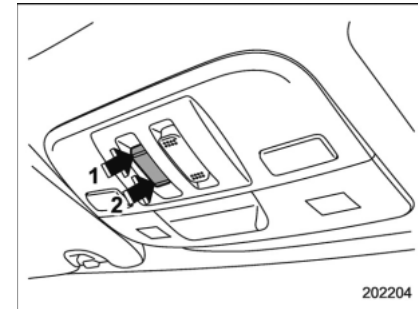

- 1) Open
- 2) Close

Tilt down the moonroof completely before performing the sliding operation.

To open:

Press the rear side of the "OPEN/CLOSE" switch. The sun shade will also be opened together with the moonroof. The moonroof will stop once at a midway position. Press the rear side of the switch again to open the moonroof completely.

To close:

Press the front side of the "OPEN/CLOSE" switch.

To stop the moonroof at a selected midway position while opening or closing it, momentarily push the switch to the "OPEN" side or "CLOSE" side.

After washing the vehicle or after it rains, wipe away water on the roof prior to opening the moonroof to prevent drops of water from falling into the passenger compartment.

NOTE

Driving with the moonroof fully open can cause an annoying sound to be generated at high speeds. If this occurs, use the moonroof at the midway stop position when the moonroof is opened.

▼ Anti-entrapment function

When the moonroof senses a substantial enough object trapped between its glass and the vehicle's roof during closure, it automatically moves back to the fully open position and stops there. The anti-entrapment function may also be activated by a strong shock on the moonroof even when there is nothing trapped.

**CAUTION**

Never attempt to test this function using fingers, hands or other parts

of your body.

NOTE

For the sake of safety, it is recommended that you avoid driving with the moonroof fully opened.

■ Sun shade

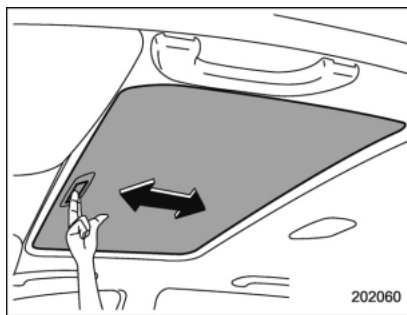

The sun shade can be slid forward or backward by hand while the moonroof is closed.

If the moonroof is opened, the sun shade also moves back.

Ignition switch (models without push-button start system).....	3-4	Front passenger's frontal airbag ON and OFF indicators	3-15
LOCK.....	3-4	CHECK ENGINE warning light/Malfunction indicator light	3-16
ACC.....	3-5	Charge warning light.....	3-17
ON.....	3-5	Oil pressure warning light.....	3-17
START	3-5	Engine low oil level warning indicator (except STI)	3-17
Key reminder chime	3-5	Windshield washer fluid warning indicator.....	3-17
Ignition switch light.....	3-6	AT OIL TEMP warning light (CVT models)	3-18
Push-button ignition switch (models with push-button start system)	3-6	Rear differential oil temperature warning light (STI)	3-18
Safety precautions	3-6	Low tire pressure warning light (U.S.-spec. models).....	3-18
Operating range for push-button start system	3-6	ABS warning light.....	3-20
Switching power	3-7	Brake system warning light.....	3-20
When access key does not operate properly	3-8	Low fuel warning light	3-21
Hazard warning flasher.....	3-8	Hill start assist warning light/Hill start assist OFF indicator light	3-22
Meters and gauges.....	3-8	Door open warning light	3-22
Combination meter illumination	3-8	All-Wheel Drive warning light (if equipped)	3-22
Canceling the function for meter/gauge needle movement upon turning on the ignition switch.....	3-9	Power steering warning light (except STI).....	3-22
Speedometer.....	3-9	LED headlight warning light (if equipped)	3-23
Odometer.....	3-9	Vehicle Dynamics Control warning light/Vehicle Dynamics Control operation indicator light.....	3-23
Double trip meter	3-9	Vehicle Dynamics Control OFF indicator light/ Traction mode indicator light.....	3-25
Tachometer	3-10	Warning chimes and warning indicator of the keyless access with push-button start system (if equipped)	3-26
Fuel gauge.....	3-10	Security indicator light.....	3-30
Temperature gauge	3-11	SI-DRIVE indicator (if equipped).....	3-31
ECO gauge	3-11		
REV indicator light and buzzer (STI).....	3-12		
Warning and indicator lights	3-13		
Seatbelt warning light and chime.....	3-13		
SRS airbag system warning light.....	3-15		

Shift-up indicator (STI).....	3-31	Selection screen.....	3-56
Select lever/gear position indicator (CVT models).....	3-31	Date and time settings.....	3-60
Turn signal indicator lights.....	3-32	Image quality and volume settings.....	3-67
High beam indicator light.....	3-32	Screen settings.....	3-69
Cruise control indicator.....	3-32	Maintenance settings.....	3-78
Cruise control set indicator.....	3-32	Driving history registration.....	3-81
Automatic headlight beam leveler warning light (models with LED headlights).....	3-32	Car settings.....	3-82
Front fog light indicator light (if equipped).....	3-32	Initialize.....	3-90
Headlight indicator light.....	3-32	Audio setting (if equipped).....	3-92
Driver's control center differential auto indicator (STI).....	3-32	Sound setting (if equipped).....	3-94
Driver's control center differential indicator and warning (STI).....	3-33	Hands-free system setting.....	3-95
REV indicator light (STI).....	3-34	Light control switch.....	3-98
Multi information display.....	3-34	Headlights.....	3-99
Basic operation.....	3-35	High/low beam change (dimmer).....	3-100
Welcome screen.....	3-35	Headlight flasher.....	3-100
Good-bye screen.....	3-35	Daytime running light system.....	3-100
Warning screen.....	3-36	Turn signal lever.....	3-101
Basic screens.....	3-41	Illumination brightness control.....	3-101
Menu screens.....	3-42	Headlight beam leveler (if equipped).....	3-102
Multi function display.....	3-45	Automatic headlight beam leveler (models with LED headlights).....	3-102
Basic operation.....	3-46	Fog light switch (if equipped).....	3-102
Welcome screen.....	3-46	Wiper and washer.....	3-103
Date screen.....	3-46	Windshield wiper and washer switches.....	3-104
Ending screen.....	3-47	Mirrors.....	3-106
Self-check screen.....	3-47	Inside mirror.....	3-106
Interruption screen.....	3-48	Auto-dimming mirror/compass (if equipped).....	3-106
Basic screens.....	3-49	Auto-dimming mirror/compass with HomeLink® (if equipped).....	3-107
		Outside mirrors.....	3-113
		Defogger and deicer.....	3-114

Tilt/telescopic steering wheel..... 3-115

Horn..... 3-116

Ignition switch (models without push-button start system)

WARNING

- Never turn the ignition switch to “LOCK” while the vehicle is being driven or towed because that will lock the steering wheel, preventing steering control. And when the engine is turned off, it takes a much greater effort than usual to steer.
- Before leaving the vehicle, always remove the key from the ignition switch for safety and never allow an unattended child to remain in the vehicle. Failure to follow this procedure could result in injury to a child or others. Children could operate the power windows, the moonroof or other controls or even make the vehicle move.

CAUTION

Do not attach a large key holder or key case to either key. If it banged

against your knees or hands while you are driving, it could turn the ignition switch from the “ON” position to the “ACC” or “LOCK” position, thereby stopping the engine. Also, if the key is attached to a keyholder or to a large bunch of other keys, centrifugal force may act on it as the vehicle moves, resulting in unwanted turning of the ignition switch.

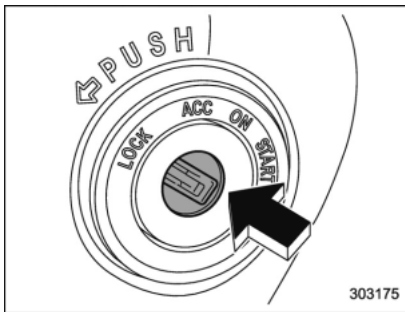

The ignition switch has four positions: LOCK, ACC, ON and START.

NOTE

- Keep the ignition switch in the “LOCK” position when the engine is not running.

- Using electrical accessories for a long time with the ignition switch in the “ON” or “ACC” position can cause the battery to go dead.
- If the ignition switch will not move from the “LOCK” position to the “ACC” position, turn the steering wheel slightly to the left and right as you turn the ignition switch.

LOCK

The key can only be inserted or removed in this position. The ignition switch will lock the steering wheel when you remove the key.

If turning the key is difficult, turn the steering wheel slightly to the right and left as you turn the key.

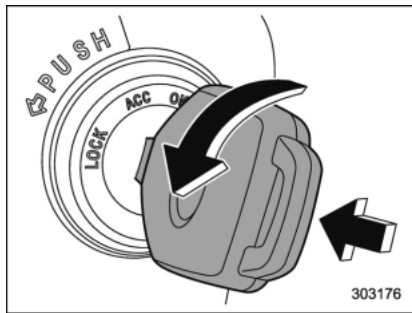

The key can be turned from the “ACC” to “LOCK” position only when the select lever is in the “P” position (CVT models) and the key is pushed in while turning it (all models).

■ ACC

In this position the electrical accessories (audio, accessory power outlet, etc.) can be used.

■ ON

This is the normal operating position after the engine is started.

■ START

The engine is started in this position. The starter cranks the engine to start it. When

the key is released (after the engine has started), the key automatically returns to the “ON” position.

⚠ CAUTION

Do not turn the ignition switch to the “START” position while the engine is running.

If your registered key fails to start the engine, pull out the key once (the security indicator light will blink), and then insert the key in the ignition switch and turn it to the “START” position and again try to start the engine.

NOTE

The engine may not start in the following cases:

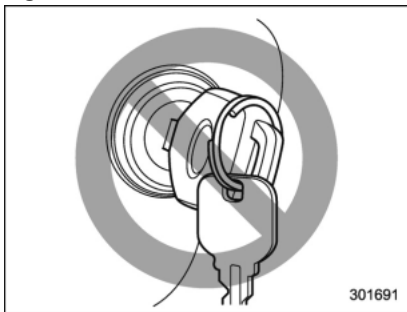

- The key grip is touching another key or a metallic key holder.

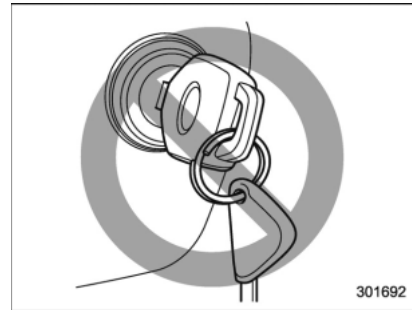

- The key is near another key that contains an immobilizer transponder.
- The key is near or touching another transmitter.

■ Key reminder chime

The reminder chime sounds when the driver’s door is opened and the ignition switch is in the “LOCK” or “ACC” position.

The chime stops under the following conditions.

- when the ignition switch is turned to the “ON” position
- when the key is removed from the ignition switch
- when the driver’s door is closed

■ Ignition switch light

For easy access to the ignition switch in the dark, the ignition switch light illuminates when the driver's door is opened or when the driver's door is unlocked using the remote keyless entry transmitter.

The light remains illuminated for several tens of seconds and then gradually turns off under the following conditions.

- when the driver's door is closed
- when the doors are unlocked using the remote keyless entry transmitter

The light turns off immediately under the following conditions.

- when the ignition switch is turned to the "ON" position
- when all doors are locked using the remote keyless entry transmitter

Push-button ignition switch (models with push-button start system)

■ Safety precautions

Refer to "Safety precautions" 2-8.

■ Operating range for push-button start system

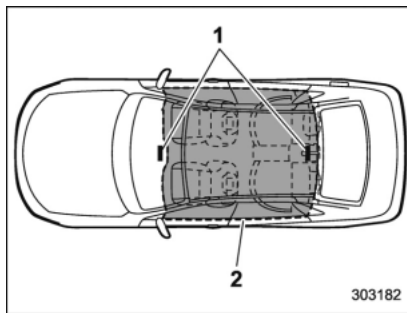

- 1) Antenna
- 2) Operating range

NOTE

- If the access key is not detected within the operating range of the antennas inside the vehicle, the push-button ignition switch and the engine start cannot be operated.

- Even when the access key is outside the vehicle, if it is placed too close to the glass, it may be possible to switch the power or to start the engine.
- Do not leave the access key in the following places. It may become impossible to operate the push-button ignition switch and the engine start.

- On the instrument panel
- On the floor
- Inside the glove box
- Inside the door trim pocket
- On the rear seat
- On the rear shelf
- Inside the trunk

- When operating the push-button ignition switch or starting the engine, if the access key battery is discharged, perform the procedure described in "Access key - if access key does not operate properly" 9-16. In such a case, replace the battery immediately. Refer to "Replacing access key battery" 11-49.

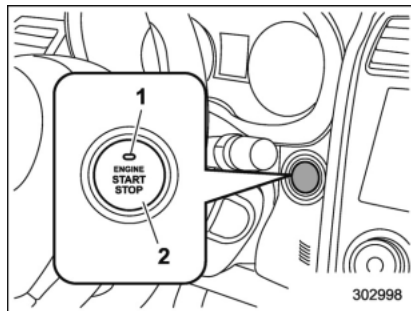
Switching power

- 1) Operation indicator
- 2) Push-button ignition switch

The power is switched every time the push-button ignition switch is pressed.

1. Carry the access key, and sit in the driver's seat.
2. Shift the shift lever in neutral (MT models) or the select lever in the "P" position (CVT models).
3. Press the push-button ignition switch without depressing the clutch pedal (MT models) or the brake pedal (CVT models). Every time the button is pressed, the power is switched in the sequence of "OFF", "ACC", "ON" and "OFF". When the engine is stopped and the push-button ignition switch is in "ACC" or "ON", the

operation indicator on the push-button ignition switch illuminates in orange.

Power status	Indicator color	Operation
OFF	Turned off	Power is turned off.
ACC	Orange	The following systems can be used: audio and accessory power outlet.
ON	Orange (while engine is stopped)	All electrical systems can be used.
	Turned off (while engine is running)	

CAUTION

- When the push-button ignition switch is left in "ON" or "ACC" for a long time, it may result in vehicle battery discharge.
- Do not spill drinks or other liquids on the push-button ignition switch. It may cause a malfunction.
- Do not touch the push-button ignition switch with a hand soiled

with oil or other contaminants. It may cause a malfunction.

- If the push-button ignition switch does not operate smoothly, stop the operation. Contact a SUBARU dealer immediately.
- If the push-button ignition switch does not illuminate even when the instrument panel illumination is turned on, have the vehicle inspected at a SUBARU dealer.
- If the vehicle was left in the hot sun for a long time, the surface of the push-button ignition switch may get hot. Be careful not to burn yourself.

NOTE

- In CVT models, the push-button ignition switch cannot be switched to "OFF" when the select lever is in a position other than "P".
- When operating the push-button ignition switch, firmly press it all the way.
- If the push-button ignition switch is pressed quickly, the power may not turn on or off.
- If the indicator light on the push-button ignition switch flashes in green when the push-button ignition switch is

- CONTINUED -

pressed, steering is locked. When this occurs, press the push-button ignition switch while turning the steering wheel left and right.

▼ **Battery drainage prevention function**

When the push-button ignition switch is left in the “ACC” or “ON” position for approximately 1 hour, the push-button ignition switch will be automatically switched to “OFF” to prevent the battery from going dead. (In CVT models, this function is activated when the select lever is in the “P” position.)

■ **When access key does not operate properly**

Refer to “Access key – if access key does not operate properly” 9-16.

Hazard warning flasher

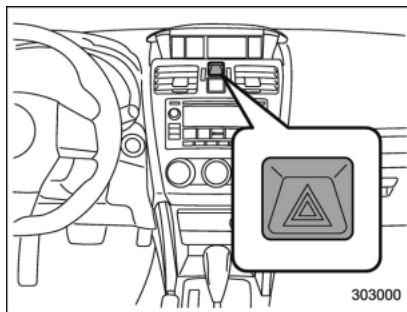

The hazard warning flasher is used to warn other drivers when you have to park your vehicle under emergency conditions. The hazard warning flasher works regardless of the position of the ignition switch.

To turn on the hazard warning flasher, push the hazard warning button on the instrument panel. To turn off the flasher, push the button again.

NOTE

When the hazard warning flasher is on, the turn signals do not work.

Meters and gauges

NOTE

Liquid-crystal displays are used in some of the meters and gauges on the combination meter. You will find their indications hard to see if you wear polarized glasses.

■ **Combination meter illumination**

When the ignition switch is turned to the “ON” position, the various parts of the combination meter are illuminated in the following sequence.

1. Warning lights, indicator lights, meter needles, gauge needles illuminate.
2. Meter and gauge indications each show MAX position.
3. Meter and gauge indications each show MIN position.
4. Regular illumination (for driving) begins.

■ Canceling the function for meter/gauge needle movement upon turning on the ignition switch

It is possible to activate or deactivate the movement of the meter needles and gauge needles that takes place when the ignition switch is turned to the "ON" position. To change the setting, perform the procedures described in "Gauge Initial Movement" 3-44.

■ Speedometer

The speedometer shows the vehicle speed. The digital speedometer can be also displayed on the multi information display.

■ Odometer

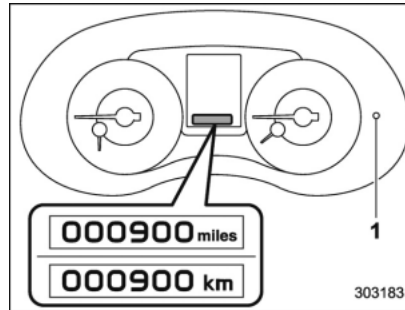

The unit displayed varies depending on the models.

- 1) Trip knob

This meter displays the odometer when the ignition switch is in the "ON" position. The odometer shows the total distance that the vehicle has been driven.

If you press the trip knob when the ignition switch is in the "LOCK"/"OFF" or "ACC" position, the odometer/trip meter will light up. If you do not press the trip knob within 10 seconds of illumination of the odometer/trip meter, the odometer/trip meter will turn off.

Also, if you open and close the driver's door within 10 seconds of illumination of the odometer/trip meter, the odometer/trip

meter will turn off.

■ Double trip meter

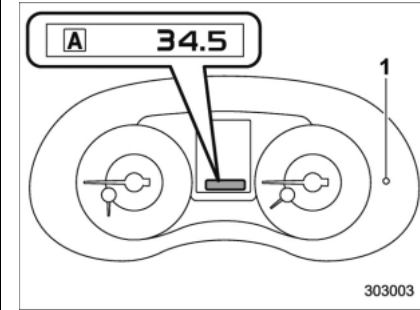

- 1) Trip knob

This meter displays the two trip meters when the ignition switch is in the "ON" position.

The trip meter shows the distance that the vehicle has been driven since you last set it to zero.

If you press the trip knob when the ignition switch is in the "LOCK"/"OFF" or "ACC" position, the odometer/trip meter will light up. It is possible to switch between the A trip meter and B trip meter indications while the odometer/trip meter is lit up. If you do not press the trip knob within 10 seconds of illumination of the odometer/trip

trip meter, the odometer/trip meter will turn off.

Also, if you open and close the driver's door within 10 seconds of illumination of the odometer/trip meter, the odometer/trip meter will turn off.

The display can be switched as shown in the following sequence by pressing the trip knob.

TRIP **A** \longleftrightarrow TRIP **B**

To set the trip meter to zero, select the A trip or B trip meter by pressing the knob and keep the knob pressed for more than 2 seconds.

CAUTION

To ensure safety, do not attempt to change the function of the indicator during driving, as an accident could result.

NOTE

If the connection between the combination meter and battery is broken for any reason such as vehicle maintenance or fuse replacement, the data recorded on the trip meter will be lost.

■ Tachometer

The tachometer shows the engine speed in thousands of revolutions per minute.

CAUTION

Do not operate the engine with the pointer of the tachometer in the red zone. This may cause severe damage to the engine.

■ Fuel gauge

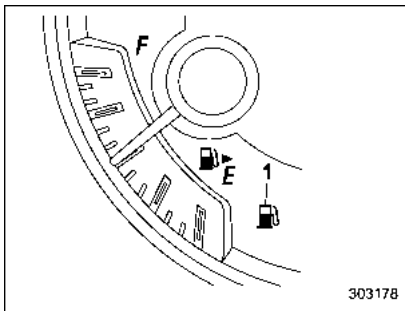

1) Low fuel warning light

The fuel gauge shows the approximate amount of fuel remaining in the tank.

When the ignition switch is in the "LOCK"/"OFF" or "ACC" position, the fuel gauge

shows "E" even if the fuel tank contains fuel.

The gauge may move slightly during braking, turning or acceleration due to fuel level movement in the tank.

If you press the trip knob while the ignition switch is in the "LOCK"/"OFF" or "ACC" position, the fuel gauge's dial will light up and the needle will indicate the amount of fuel remaining in the tank.

If, while the fuel gauge needle is indicating the amount of fuel remaining in the tank, you (a) do not press the trip knob for 10 seconds or (b) open and close the driver's door, the fuel gauge needle will drop to the "E" position and the dial and needle will turn off.

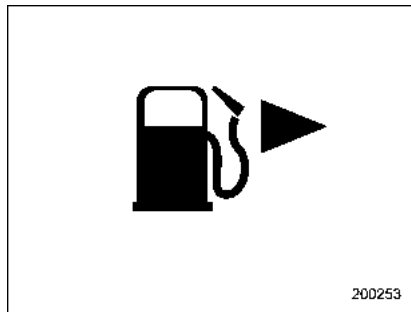
NOTE

200253

- You will see the “” sign in the fuel gauge.

This indicates that the fuel filler door (lid) is located on the right side of the vehicle.

- When you have refueled, the fuel gauge indicates the amount in the fuel tank after starting the engine. Also, it may take some time until the fuel gauge indication stabilizes.

• The gauge indicates only an approximate amount of fuel remaining in the tank. Use this indication only as a guide.

- If you refuel while the ignition switch is in the “ON” position, the fuel gauge may not indicate the correct amount of

the fuel in the fuel tank.

- If the refuel amount is less than approximately 4.0 US gal (15 liters, 3.3 Imp gal), it may take some time until the fuel gauge indication stabilizes.

■ Temperature gauge

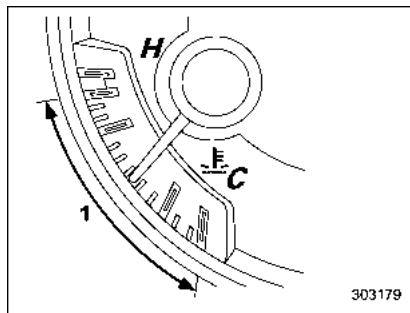

303179

- 1) Normal operating range

The temperature gauge shows engine coolant temperature when the ignition switch is in the “ON” position.

The coolant temperature will vary in accordance with the outside temperature and driving conditions.

We recommend that you drive moderately until the pointer of the temperature gauge reaches near the middle of the range.

Engine operation is optimum with the engine coolant at this temperature range and high revving operation when the engine is not warmed up enough should be avoided.

**CAUTION**

If the pointer exceeds the normal operating range, safely stop the vehicle as soon as possible.

Refer to “Engine overheating” 9-11.

■ ECO gauge

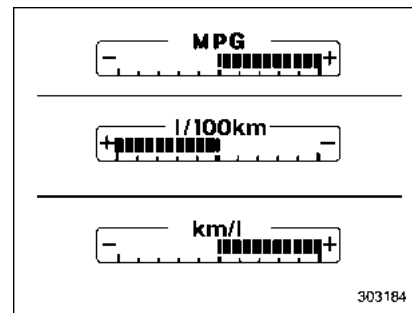

303184

The unit displayed varies depending on the models.

The ECO gauge shows the difference

3-12 Instruments and controls/REV indicator light and buzzer (STI)

between the average rate of fuel consumption since the trip meter was last reset and the current rate of fuel consumption.

The ECO gauge indicates the current fuel efficiency as shown in the following chart.

Displayed unit	Needle position	
	"+" side	"-" side
MPG	Better	Poorer
l/100km	Poorer	Better
km/l	Better	Poorer

NOTE

- The ECO gauge shows only an approximate indication.
- After resetting the trip meter, the average rate of fuel consumption is not shown until driving 0.6 mile (1 km). Until that time, the ECO gauge does not operate.

REV indicator light and buzzer (STI)

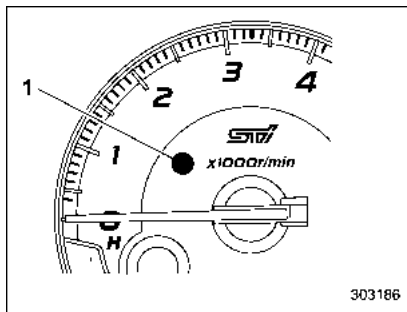

- 1) REV indicator light

The REV alarm system has the following functions.

- When the engine speed reaches the level that was previously set, the REV indicator light illuminates to inform you. At this time, a buzzer also sounds if the buzzer setting is activated.
- Whenever the engine speed enters the red zone of the tachometer, the REV indicator light flashes.

NOTE

Even if the REV alarm system is not set, the REV indicator light will flash when-

ever the engine speed enters the red zone of the tachometer.

To change the REV indicator settings, perform the procedures described in "REV settings (STI)" 3-44.

Warning and indicator lights

Several of the warning and indicator lights illuminate when the ignition switch is initially turned to the "ON" position. This permits checking the operation of the bulbs.

Apply the parking brake and turn the ignition switch to the "ON" position. For the system check, the following lights illuminate and then turn off after several seconds or after the engine has started.

: Seatbelt warning light

(The seatbelt warning light turns off only when the driver fastens the seatbelt.)

: Front passenger's seatbelt warning light

(The seatbelt warning light turns off only when the front seat passenger fastens the seatbelt.)

: SRS airbag system warning light

ON / : Front passenger's frontal airbag ON indicator light

OFF / : Front passenger's frontal airbag OFF indicator light

: CHECK ENGINE warning light/Malfunction indicator light

: Charge warning light

: Oil pressure warning light

: REV indicator light (STI)

: AT OIL TEMP warning light (CVT models)

: Rear differential oil temperature warning light (STI)

: Low tire pressure warning light (U.S.- spec. models)

ABS / : ABS warning light

BRAKE / : Brake system warning light

: Low fuel warning light

: Hill start assist warning light/Hill start assist OFF indicator light

: Door open warning light

AWD: AWD warning light (if equipped)

: Power steering warning light (except STI)

: Vehicle Dynamics Control warning light/Vehicle Dynamics Control operation indicator light

: Vehicle Dynamics Control OFF indicator light

: LED headlight warning light

: Headlight indicator light

: Automatic headlight beam leveler warning light (if equipped)

: Traction mode indicator light

If any lights fail to illuminate, it indicates a burned-out bulb or a malfunction of the corresponding system.

Consult your authorized SUBARU dealer for repair.

Seatbelt warning light and chime



Your vehicle is equipped with a seatbelt warning device at the driver's and front passenger's seat, as required by current safety standards.

With the ignition switch turned to the "ON" position, this device reminds the driver and front passenger to fasten their seatbelts by illuminating the warning lights in the locations indicated in the following illustration and sounding a chime.

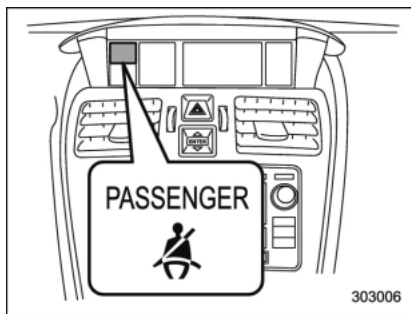
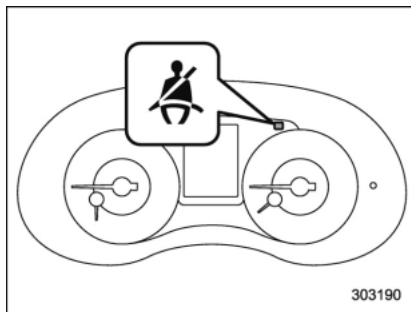

Front passenger's warning light

▼ Operation

If the driver and/or front passenger have/has not yet fastened the seatbelt(s) when the ignition switch is turned to the "ON" position, the seatbelt warning light(s) will

flash for 6 seconds, to warn that the seatbelt(s) is/are unfastened. If the driver's seatbelt is not fastened, a chime will also sound simultaneously.

NOTE

- If the driver's and/or front passenger's seatbelt(s) are/is still not fastened 6 seconds later, the seatbelt warning device operates as follows according to the vehicle speed.

- At speeds lower than approximately 9 mph (15 km/h)

The warning light(s) for unfastened seatbelt(s) will alternate between steady illumination and flashing at 15-second intervals. The chime will not sound.

- At speeds higher than approximately 9 mph (15 km/h)

The warning light(s) for unfastened seatbelt(s) will alternate between flashing and steady illumination at 15-second intervals and the chime will sound while the warning light(s) is/are flashing.

- It is possible to cancel the warning operation that follows the 6-second warning after turning ON the ignition switch. When the ignition switch is turned ON next time, however, the complete sequence of the warning

operation resumes. For further details about canceling the warning operation, please contact your SUBARU dealer.

If there is no passenger on the front passenger's seat, the seatbelt warning device for the front passenger's seat will be deactivated. The front passenger's occupant detection system monitors whether or not there is a passenger on the front passenger's seat.

Observe the following precautions. Failure to do so may prevent the device from functioning correctly or cause the device to fail.

- Do not install any accessory such as a table or TV onto the seatback.
- Do not store a heavy load in the seatback pocket.
- Do not allow the rear seat occupant to place his/her hands or legs on the front passenger's seatback, or allow him/her to pull the seatback.
- Do not use front seats with their backward-forward position and seatback not being locked into place securely. If any of them are not locked securely, adjust them again. For adjusting procedure, refer to "Front seats" 1-2.

If the seatbelt warning device for the front passenger's seat does not function correctly (e.g., it is activated even when the

front passenger's seat is empty or it is deactivated even when the front passenger has not fastened his/her seatbelt), take the following actions.

- Ensure that no article is placed on the seat other than a child restraint system and its child occupant, although we strongly recommend that all children sit in the rear seat properly restrained.
- Ensure that there is no article left in the seatback pocket.
- Ensure that the backward-forward position and seatback of front passenger's seat are locked into place securely by moving the seat back and forth.

If still the seatbelt warning device for front passenger's seat does not function correctly after taking relevant corrective actions described above, immediately contact your SUBARU dealer for an inspection.

■ SRS airbag system warning light



For details about the SRS airbag system warning light, refer to "SRS airbag system monitors" 1-56.

▲ WARNING

If the warning light exhibits any of the following conditions, there may be a malfunction in the seatbelt pretensioners and/or SRS airbag system. Immediately take your vehicle to your nearest SUBARU dealer to have the system checked. Unless checked and properly repaired, the seatbelt pretensioners and/or SRS airbag will not operate properly in the event of a collision, which may increase the risk of injury.

- **Flashing or flickering of the warning light**
- **No illumination of the warning light when the ignition switch is first turned to the "ON" position**
- **Continuous illumination of the warning light**
- **Illumination of the warning light while driving**

■ Front passenger's frontal airbag ON and OFF indicators

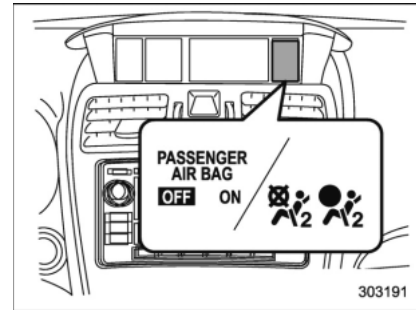

ON / : Front passenger's frontal airbag ON indicator

OFF / : Front passenger's frontal airbag OFF indicator

The front passenger's frontal airbag ON and OFF indicators show you the status of the front passenger's SRS frontal airbag. The indicators are located next to the clock in the center portion of the dashboard.

When the ignition switch is turned to the "ON" position, both the ON and OFF indicators illuminate for 6 seconds during which time the system is checked. Following the system check, both indicators turn off for 2 seconds. After that, one of the

indicators illuminates depending on the status of the front passenger's SRS frontal airbag determined by the SUBARU advanced frontal airbag system monitoring. If the front passenger's SRS frontal airbag is activated, the passenger's frontal airbag ON indicator will illuminate while the OFF indicator will remain off.

If the front passenger's SRS frontal airbag is deactivated, the passenger's frontal airbag ON indicator will remain off while the OFF indicator will illuminate.

With the ignition switch turned to the "ON" position, if both the ON and OFF indicators remain illuminated or off simultaneously even after the system check period, the system is malfunctioning. Contact your SUBARU dealer immediately for an inspection.

■ CHECK ENGINE warn- ing light/Malfunction in- dicator light

CHECK
ENGINE



CAUTION

If the CHECK ENGINE light illuminates while you are driving, have your vehicle checked/repaired by your SUBARU dealer as soon as possible. Continued vehicle operation without having the emission control system checked and repaired as necessary could cause serious damage, which may not be covered by your vehicle's warranty.

If this light illuminates steadily or blinks while the engine is running, it may indicate that there is a problem or potential problem somewhere in the emission control system.

▼ If the light illuminates steadily

If the light illuminates steadily while driving or does not turn off after the engine starts, an emission control system malfunction has been detected.

You should have your vehicle checked by an authorized SUBARU dealer immediately.

NOTE

This light also illuminates when the fuel filler cap is not tightened until it clicks.

If you have recently refueled your vehicle, the cause of the CHECK ENGINE warning light/malfunction indicator light illuminating could be a loose or missing fuel filler cap. Remove the cap and retighten it until it clicks. Make sure nothing is interfering with the sealing of the cap. Tightening the cap will not make the CHECK ENGINE warning light turn off immediately. It may take several driving trips. If the light does not turn off, take your vehicle to your authorized SUBARU dealer immediately.

▼ If the light is blinking

If the light is blinking while driving, an engine misfire condition has been detected which may damage the emission control system.

To prevent serious damage to the emission control system, you should do the following.

- Reduce vehicle speed.
- Avoid hard acceleration.
- Avoid steep uphill grades.
- Reduce the amount of cargo, if possible.

The CHECK ENGINE warning light may stop blinking and illuminate steadily after

several driving trips. You should have your vehicle checked by an authorized SUBARU dealer immediately.

■ Charge warning light



If this light illuminates when the engine is running, it may indicate that the charging system is not working properly.

If the light illuminates while driving or does not turn off after the engine starts, stop the engine at the first safe opportunity and check the alternator belt. If the belt is loose, broken or if the belt is in good condition but the light remains illuminated, contact your nearest SUBARU dealer immediately.

■ Oil pressure warning light



If this light illuminates when the engine is running, it may indicate that the engine oil pressure is low and the lubricating system is not working properly.

If the light illuminates while driving or does not turn off after the engine starts, stop the engine at the first safe opportunity and check the engine oil level. If the oil level is low, add oil immediately. If the engine oil is at the proper level but the light remains illuminated, contact your nearest SUBARU dealer immediately.

For details about checking the engine oil level or adding the engine oil, refer to "Engine oil" 11-12.

▲ CAUTION

Do not operate the engine with the oil pressure warning light illuminated. This may cause serious engine damage.

■ Engine low oil level warning indicator (except STI)



This indicator appears when the engine oil level decreases to the lower limit.

If the engine low oil level warning indicator appears while driving, park the vehicle in a safe and level location, and then check the engine oil level. When the engine oil level is not within the normal range, refill with engine oil. Refer to "Engine oil" 11-12.

If the warning indicator does not disappear after refilling the engine oil, or the warning indicator appears even though the engine oil level is within the normal range, have the vehicle checked by a SUBARU dealer.

NOTE

- After replacing or adding the engine oil, if the engine oil level is within the normal range when restarting the engine on a level surface, the warning indicator will disappear.
- The warning indicator may appear temporarily in the following conditions because a low oil level may be detected as a result of significant oil movement in the engine.

- when the vehicle is considerably inclined on an uphill or steep slope
- when the vehicle has continuously accelerated and decelerated
- when the vehicle is continuously turned
- when the vehicle is driven on a road that alternates continuously between uphill and downhill

■ Windshield washer fluid warning indicator



This indicator appears when the fluid level in the windshield washer fluid tank decreases to the lower limit (approximately 1.1 US qt, 1.0 liter, 0.9 Imp qt).

■ **AT OIL TEMP warning light (CVT models)**

AT OIL
TEMP

If this light illuminates when the engine is running, it may indicate that the transmission fluid temperature is too hot.

If the light illuminates while driving, immediately stop the vehicle in a safe place and let the engine idle until the warning light turns off.

▼ **Transmission control system warning**

If the "AT OIL TEMP" warning light flashes after the engine has started, it may indicate that the transmission control system is not working properly. Contact your nearest SUBARU dealer for service immediately.

■ **Rear differential oil temperature warning light (STI)**

R.DIFF
TEMP



CAUTION

If the R.DIFF TEMP warning light illuminates, reduce vehicle speed and stop the vehicle in a safe location as soon as possible. Continuing to drive with this light illuminated may damage the rear differ-

ential and other parts of the powertrain.

If this light illuminates when the engine is running, it may indicate that the rear differential oil temperature is too hot.

At this time, the driver's control center differential will automatically cancel the current torque-distribution ratio setting and adopt its minimum ratio.

If the light illuminates while driving, reduce vehicle speed and stop the vehicle in the nearest safe location. Park the vehicle for several minutes. After the light turns off, you can start driving.

If the light does not turn off, contact the nearest SUBARU dealer for service.

NOTE

- If the tire pressures are not correct and/or the tires are not all the same size and brand, the rear differential will be heavily loaded when the vehicle is driven, resulting in an abnormally high oil temperature.
- The rear differential oil will deteriorate if its temperature increases enough for the rear differential oil temperature warning light to illuminate. It is advisable to have the rear differential oil replaced as soon as possible.

■ **Low tire pressure warning light (U.S.-spec. models)**



When the ignition switch is turned to the "ON" position, the low tire pressure warning light will illuminate for approximately 2 seconds to check that the tire pressure monitoring system (TPMS) is functioning properly. If there is no problem and all tires are properly inflated, the light will turn off.

Each tire, including the spare (if provided), should be checked monthly when cold and inflated to the inflation pressure recommended by the vehicle manufacturer on the vehicle placard or tire inflation pressure label. (If your vehicle has tires of a different size than the size indicated on the vehicle placard or tire inflation pressure label, you should determine the proper tire inflation pressure for those tires.)

As an added safety feature, your vehicle has been equipped with a tire pressure monitoring system (TPMS) that illuminates a low tire pressure telltale when one or more of your tires is significantly under-inflated. Accordingly, when the low tire pressure telltale illuminates, you should stop and check your tires as soon as possible, and inflate them to the proper pressure. Driving on a significantly under-

inflated tire causes the tire to overheat and can lead to tire failure. Under-inflation also reduces fuel efficiency and tire tread life, and may affect the vehicle's handling and stopping ability.

Please note that the TPMS is not a substitute for proper tire maintenance, and it is the driver's responsibility to maintain correct tire pressure, even if under-inflation has not reached the level to trigger illumination of the TPMS low tire pressure telltale.

Your vehicle has also been equipped with a TPMS malfunction indicator to indicate when the system is not operating properly. The TPMS malfunction indicator is combined with the low tire pressure telltale. When the system detects a malfunction, the telltale will flash for approximately one minute and then remain continuously illuminated. This sequence will continue upon subsequent vehicle start-ups as long as the malfunction exists. When the malfunction indicator is illuminated, the system may not be able to detect or signal low tire pressure as intended. TPMS malfunctions may occur for a variety of reasons, including the installation of replacement or alternate tires or wheels on the vehicle that prevent the TPMS from functioning properly. Always check the TPMS malfunction telltale after replacing

one or more tires or wheels on your vehicle to ensure that the replacement or alternate tires and wheels allow the TPMS to continue to function properly.

Should the warning light illuminate steadily after blinking for approximately one minute, have the system inspected by your nearest SUBARU dealer as soon as possible.



WARNING

If this light does not illuminate briefly after the ignition switch is turned ON or the light illuminates steadily after blinking for approximately one minute, you should have your Tire Pressure Monitoring System checked at a SUBARU dealer as soon as possible.

If this light illuminates while driving, never brake suddenly and keep driving straight ahead while gradually reducing speed. Then slowly pull off the road to a safe place. Otherwise an accident involving serious vehicle damage and serious personal injury could occur.

If this light still illuminates while driving after adjusting the tire pressure, a tire may have significant damage and a fast leak that causes

the tire to lose air rapidly. If you have a flat tire, replace it with a spare tire as soon as possible.

When a spare tire is mounted or a wheel rim is replaced without the original pressure sensor/transmitter being transferred, the Low tire pressure warning light will illuminate steadily after blinking for approximately one minute. This indicates the TPMS is unable to monitor all four road wheels. Contact your SUBARU dealer as soon as possible for tire and sensor replacement and/or system resetting.

If the light illuminates steadily after blinking for approximately one minute, promptly contact a SUBARU dealer to have the system inspected.



CAUTION

The tire pressure monitoring system is NOT a substitute for manually checking tire pressure. The tire pressure should be checked periodically (at least monthly) using a tire gauge. After any change to tire pressure(s), the tire pressure monitoring system will not re-check tire inflation pressures until the vehicle

is first driven more than 20 mph (32 km/h). After adjusting the tire pressures, increase the vehicle speed to at least 20 mph (32 km/h) to start the TPMS re-checking of the tire inflation pressures. If the tire pressures are now above the severe low pressure threshold, the low tire pressure warning light should turn off a few minutes later. Therefore, be sure to install the specified size for the front and rear tires.

■ **ABS warning light** ABS / 

 **CAUTION**

- If any of the following conditions occur, we recommend that you have the ABS system repaired at the first available opportunity by your SUBARU dealer.
 - The warning light does not illuminate when the ignition switch is turned to the “ON” position.
 - The warning light illuminates during driving.
- When the warning light is on (and the brake system warning light is off), the ABS function shuts

down. However, the conventional brake system continues to operate normally.

The ABS warning light illuminates together with the brake system warning light if the EBD system malfunctions. For further details of the EBD system malfunction warning, refer to “Electronic Brake Force Distribution (EBD) system warning” 3-21.

NOTE

If the warning light behavior is as described in the following conditions, the ABS system may be considered normal.

- The warning light illuminates when the ignition switch is turned to the “ON” position and turns off approximately 2 seconds after the engine has started.
- The warning light illuminates right after the engine is started but turns off immediately, remaining off.
- The warning light remains illuminated after the engine has been started, but it turns off while driving.
- The warning light illuminates during driving, but it turns off immediately and remains off.

When driving with an insufficient battery

voltage such as when the engine is jump started, the ABS warning light may illuminate. This is due to the low battery voltage and does not indicate a malfunction. When the battery becomes fully charged, the light will turn off.

■ **Brake system warning light**

BRAKE / 

 **WARNING**

- Driving with the brake system warning light on is dangerous. This indicates your brake system may not be working properly. If the light remains illuminated, have the brakes inspected by a SUBARU dealer immediately.
- If at all in doubt about whether the brakes are operating properly, do not drive the vehicle. Have your vehicle towed to the nearest SUBARU dealer for repair.

This light has the following functions.

▼ **Parking brake warning**

The light illuminates with the parking brake applied while the ignition switch is in the “ON” position. It turns off when the parking brake is fully released.

▼ Brake fluid level warning

This light illuminates when the brake fluid level has dropped to near the "MIN" level of the brake fluid reservoir with the ignition switch in the "ON" position and with the parking brake fully released.

If the brake system warning light should illuminate while driving (with the parking brake fully released and with the ignition switch positioned in "ON"), it could be an indication of leaking of brake fluid or worn brake pads. If this occurs, immediately stop the vehicle at the nearest safe place and check the brake fluid level. If the fluid level is below the "MIN" mark in the reservoir, do not drive the vehicle. Have the vehicle towed to the nearest SUBARU dealer for repair.

▼ Electronic Brake Force Distribution (EBD) system warning

The brake system warning light also illuminates if a malfunction occurs in the EBD system. In that event, it illuminates together with the ABS warning light.

The EBD system may be malfunctioning if the brake system warning light and ABS warning light illuminate simultaneously during driving.

Even if the EBD system fails, the conventional braking system will still function. However, the rear wheels will be more

prone to locking when the brakes are applied harder than usual and the vehicle's motion may therefore become somewhat harder to control.

If the brake system warning light and ABS warning light illuminate simultaneously, take the following steps.

1. Stop the vehicle in the nearest safe, flat place.
2. Shut down the engine, apply the parking brake and then restart it.
3. Release the parking brake. If both warning lights turn off, the EBD system may be malfunctioning. Drive carefully to the nearest SUBARU dealer and have the system inspected.
4. If both warning lights illuminate again and remain illuminated after the engine has been restarted, shut down the engine again, apply the parking brake, and check the brake fluid level.
5. If the brake fluid level is not below the "MIN" mark, the EBD system may be malfunctioning. Drive carefully to the nearest SUBARU dealer and have the system inspected.
6. If the brake fluid level is below the "MIN" mark, DO NOT drive the vehicle. Instead, have the vehicle towed to the nearest SUBARU dealer for repair.

▼ Vacuum pump system warning (except STI)

This light illuminates when a malfunction is detected in the vacuum pump system.

NOTE

The vacuum pump system assists the boost pressure when driving at high altitudes while the engine is cold.

■ Low fuel warning light



The low fuel warning light illuminates when the tank is nearly empty, at approximately 2.6 US gal (10.0 liters, 2.2 Imp gal). It only operates when the ignition switch is in the "ON" position.



CAUTION

Promptly put fuel in the tank whenever the low fuel warning light illuminates. Engine misfires as a result of an empty tank could cause damage to the engine.

NOTE

This light does not turn off unless the tank is replenished up to an internal fuel quantity of approximately 4.5 US gal (17 liters, 3.7 Imp gal).

■ **Hill start assist warning light/Hill start assist OFF indicator light** 

▼ **Hill start assist warning light**

While the engine is running, if there are any malfunctions in the Hill start assist system, the warning light will illuminate.

 **WARNING**

When the Hill start assist warning light illuminates, have the vehicle inspected at an authorized SUBARU dealer.

▼ **Hill start assist OFF indicator light**

While the Hill start assist system is deactivated, the Hill start assist OFF indicator light illuminates continuously to inform the driver that the Hill start assist system is not operational.

■ **Door open warning light** 

The warning light illuminates if any door or the trunk lid is not fully closed. This function is effective even if the ignition switch is in the "LOCK"/"OFF" or "ACC" position, or the key is removed from the

ignition switch.

Always make sure this light is not illuminated before you start to drive.

■ **All-Wheel Drive warning light (if equipped)** AWD 

This light flashes if the vehicle is driven with tires of differing diameters fitted on the wheels or with an excessively low air pressure in any of the tires.

 **CAUTION**

Continuing to drive with the AWD warning light flashing can damage the powertrain. If the AWD warning light starts to flash, promptly park in a safe place and check whether the tires have differing diameters and whether any of the tires has an excessively low inflation pressure.

■ **Power steering warning light (except STI)** 

This warning light illuminates when the ignition switch is turned to the "ON" position and turns off after the engine has started. This indicates that the warning system is working properly.

While the engine is running, this warning light illuminates when a malfunction has been detected in the electric power steering system.

 **CAUTION**

When the power steering warning light is illuminated, there may be more resistance when the steering wheel is operated. Drive carefully to the nearest SUBARU dealer and have the vehicle inspected immediately.

NOTE

If the steering wheel is operated in the following ways, the power steering control system may temporarily limit the power assist in order to prevent the system components, such as the control computer and drive motor, from overheating.

- The steering wheel is operated frequently and turned sharply while the vehicle is maneuvered at extremely low speeds, such as while frequently turning the steering wheel during parallel parking.
- The steering wheel remains in the fully turned position for a long period of time.

At this time, there will be more resistance when steering. However this is not a malfunction. Normal steering force will be restored after the steering wheel is not operated for a while and the power steering control system has an opportunity to cool down. However, if the power steering is operated in a non-standard way which causes power assist limitation to occur too frequently, that may result in a malfunction of the power steering control system.

■ LED headlight warning light (if equipped)

This light illuminates if the LED headlights malfunction. Have your vehicle inspected at a SUBARU dealer as soon as possible.

■ Vehicle Dynamics Control warning light/ Vehicle Dynamics Control operation indicator light



▼ Vehicle Dynamics Control warning light

CAUTION

The Vehicle Dynamics Control system provides its ABS control through the electrical circuit of the ABS system. Accordingly, if the ABS is inoperative, the Vehicle Dynamics Control system becomes unable to provide ABS control. As a result, the Vehicle Dynamics Control system also becomes inoperative, causing the warning light to illuminate. Though both the Vehicle Dynamics Control and ABS systems are inoperative in this case, the ordinary functions of the brake system are still available. You will be safe while driving with this condition, but drive carefully and have your vehicle checked at a SUBARU dealer as soon as possible.

NOTE

- If the electrical circuit of the Vehicle Dynamics Control system itself malfunctions, the warning light only illuminates. At this time, the ABS (Anti-lock Brake System) remains fully operational.
- The warning light illuminates when the electronic control system of the ABS/Vehicle Dynamics Control system malfunctions.

The Vehicle Dynamics Control system is probably inoperative under any of the following conditions. Have your vehicle checked at a SUBARU dealer immediately.

- The warning light does not illuminate when the ignition switch is turned to the "ON" position.
- The warning light illuminates while the vehicle is running.

NOTE

If the warning light behavior is as described in the following examples, the Vehicle Dynamics Control system may be considered normal.

- The warning light illuminates when the ignition switch is turned to the "ON" position and turns off approximately 2 seconds after the engine has started.

- The warning light illuminates right after the engine is started but turns off immediately, remaining off.
- The warning light illuminates after the engine has started and turns off while the vehicle is subsequently being driven.
- The warning light illuminates during driving, but it turns off immediately and remains off.
- The warning light illuminates when the engine has stalled and continues to illuminate after the engine has been restarted. However, it will turn off once the vehicle starts moving.

▼ **Vehicle Dynamics Control operation indicator light**

The indicator light flashes during activation of the skid suppression function and during activation of the traction control function.

NOTE

- The light may remain illuminated for a short period of time after the engine has been started, especially in cold weather. This does not indicate the existence of a problem. The light should turn off as soon as the engine has warmed up.
- The indicator light illuminates when the engine has developed a problem



and the CHECK ENGINE warning light/malfunction indicator light is on.

The Vehicle Dynamics Control system is probably malfunctioning under the following condition. Have your vehicle checked at a SUBARU dealer as soon as possible.

- The light does not turn off even after the lapse of several minutes (the engine has warmed up) after the engine has started.

■ Vehicle Dynamics Control OFF indicator light/Traction mode indicator light

The indicator light shows the activated/deactivated conditions as follows.

		Activated/deactivated status for each function		
		Traction Control	Vehicle Dynamics Control system	ABS
Indicator light	Turn off	Activated	Activated	Activated
		Deactivated	Activated	Activated
		Deactivated	Deactivated	Activated

For details about the Traction Control and Vehicle Dynamics Control system, refer to “Vehicle Dynamics Control system” 7-38.

▼ Vehicle Dynamics Control OFF indicator light

This light illuminates when the Vehicle Dynamics Control OFF switch is operated to select the traction mode or the Vehicle Dynamic Control OFF mode. For details, refer to “Vehicle Dynamics Control system” 7-38.

NOTE

- The light may remain illuminated for a while after the engine has been started, especially in cold weather. This does not indicate the existence of a problem. The light should turn off as soon as the engine has warmed up.
- The indicator light illuminates when the engine has developed a problem and the CHECK ENGINE warning light/malfunction indicator light is on.

The Vehicle Dynamics Control system is probably malfunctioning under the following conditions. Have your vehicle checked at a SUBARU dealer as soon as possible.

- The light does not illuminate when the ignition switch is turned to the “ON” position.
- The light does not turn off even after the lapse of several minutes (the engine has warmed up) after the engine has started.

▼ **Traction mode indicator light**

The light illuminates when the Vehicle Dynamics Control OFF switch is pressed briefly to select the traction mode. For details, refer to "Traction mode" 7-40.

■ **Warning chimes and warning indicator of the keyless access with push-button start system (if equipped)**

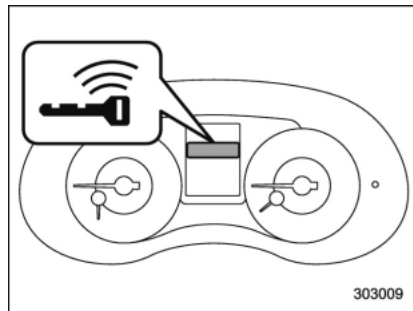

Access key warning light

The keyless access with push-button start system sounds a warning chime and the access key warning indicator appears on the combination meter in order to minimize improper operations and help protect your vehicle from theft.

When the warning chime sounds and/or the warning indicator appears, take the

appropriate action.

▲ WARNING

Never drive the vehicle if the indicator on the push-button ignition switch is flashing in green when starting the engine. This indicates the status that the steering wheel is not released and could result in an accident involving serious injury or death.

▲ CAUTION

- When starting the engine again after the operation indicator on the push-button ignition switch flashes in green, if the operation indicator is still flashing in green, there could be a steering lock malfunction. Contact your SUBARU dealer as soon as possible.
- When the operation indicator on the push-button ignition switch flashes in orange, contact a SUBARU dealer immediately.

NOTE

- Even when the access key is within the operating ranges inside the vehicle, the access key warning for engine start may be provided depending on the status of the access key and the environmental conditions.
- When the access key is taken out of the vehicle through an open window, the access key takeout warning or passenger access key takeout warning will not be provided.

▼ **List of warnings**

▲ CAUTION

When any of the following warnings occurs even if the access key warning indicator does not appear, take the appropriate action.

Inside warning chime	Outside warning chime	Operation indicator on push-button ignition switch	Status	Action
Ding, ding ... (intermittent)	—	—	The driver's door was opened while the push-button ignition switch is "ACC" (in CVT models, when the select lever is in the "P" position.)	Switch the push-button ignition switch to "OFF", or close the driver's door. *When exiting the vehicle, be sure to switch the push-button ignition switch to "OFF".
			The push-button ignition switch was switched to "OFF" while the driver's door is open.	Close the driver's door.
Ding	Short beep (2 seconds)	—	Lockout warning: All doors were closed after the locking of all doors was set by using the door lock lever or power door locking switch while the access key is inside the vehicle.	Take out the access key from the vehicle, and lock the doors. *The doors cannot be locked while the access key is inside the vehicle. *A chirp sound will be heard, and all doors will be unlocked.
—	Short beep (2 seconds)	—	Trunk lockout warning: The trunk was closed with the access key in it while all doors are locked (or during the automatic lock time period).	Take out the access key from the trunk, and close the trunk. *By pressing the trunk opener button after this warning chime sounds, the trunk can be unlocked.
			Access key lock-in warning: The door lock sensor was touched while the push-button ignition switch is "OFF" and the access key is inside the vehicle.	Take out the access key from the vehicle, and lock the doors. *If the access key is inside the vehicle, the doors cannot be locked.
—	Beep, beep ... (5 beeps)	—	Door ajar warning: The door lock sensor is touched while the push-button ignition switch is in the "OFF" position and another door or the trunk is opened.	Close the doors securely and lock them. *If one of the doors is opened, the doors cannot be locked.

3-28 Instruments and controls/Warning and indicator lights

Inside warning chime	Outside warning chime	Operation indicator on push-button ignition switch	Status	Action
Ding	Long beep (60 seconds max.)	—	Power warning: The door lock sensor was touched while carrying the access key and the push-button ignition switch is in a position other than "OFF" and the select lever is in the "P" position.	Open the door and return the access key inside the vehicle, or switch the push-button ignition switch to "OFF". *If the push-button ignition switch is not switched to "OFF", the doors cannot be locked.
Ding, ding ... (7 seconds)	—	—	Access key warning: The vehicle was driven while the access key is not inside the vehicle.	Carry the access key, and drive the vehicle.
Ding	—	—	Access key warning for engine start: The push-button ignition switch was pressed while the access key is not inside the vehicle.	Carry the access key, and press the push-button ignition switch.
Ding	Beep, beep, beep (3 beeps)	—	Access key takeout warning: The driver exited the vehicle with the access key and closed the driver's door while the push-button ignition switch is in a position other than "OFF" and the select lever is in the "P" position.	Switch the push-button ignition switch to "OFF", and get out of the vehicle.
Ding	Beep, beep, beep (3 beeps)	—	Passenger access key takeout warning: A fellow passenger exited the vehicle with the access key and closed a door other than the driver's door while the push-button ignition switch is in a position other than "OFF".	Return the access key to inside the vehicle, or switch the push-button ignition switch to "OFF".
Long beep (continuous)	Long beep (continuous)	—	The driver exited the vehicle with the access key and closed the driver's door while the push-button ignition switch is in a position other than "OFF" and the select lever is in a position other than the "P" position.	Shift the select lever to the "P" position, switch the push-button ignition switch to "OFF" and exit the vehicle.

Inside warning chime	Outside warning chime	Operation indicator on push-button ignition switch	Status	Action
Long beep (continuous)	—	—	Select lever position warning: The driver's door was opened while the push-button ignition switch is in a position other than "OFF" and the select lever is in a position other than the "P" position.	Shift the select lever to the "P" position, switch the push-button ignition switch to "OFF" and exit the vehicle.
Ding	—	—	The battery of the access key is low.	Replace the battery of the access key.
Ding	—	Flashes in green (15 seconds max.)	Steering lock warning: The engine start procedure was performed, but the steering is still locked.	While turning the steering wheel right and left lightly, depress the brake pedal and press the push-button ignition switch.
Ding	—	Flashes in orange	System malfunction warning: A malfunction was detected in the power system or steering lock.	Contact a SUBARU dealer immediately and have the vehicle inspected.

NOTE

An electronic chirp will sound while the select lever is in the "R" position. In this case, the select lever position warning chime will not sound.

■ Security indicator light

This indicator light shows the status of the alarm system. It also indicates operation of the immobilizer system.

▼ Alarm system

It blinks to show the driver the operational status of the alarm system. For detailed information, refer to "Alarm system"  2-21.

▼ Immobilizer system

The security indicator light starts blinking in the following conditions.

For models with "keyless access with push-button start system":

- Immediately after the push-button ignition switch is turned to the "OFF" position.
- Immediately after the driver's door is opened or closed when all of the following conditions are met.
 - The push-button ignition switch is in the "ON" or "ACC" position.
 - The access key is outside the vehicle.
 - The engine is not running.
 - In the event that an unauthorized key is used (for example, the key is unregistered or the ID code does not match), the power is not switched to "ON" and the security indicator light

continues blinking.

For models without "keyless access with push-button start system":

- Approximately 60 seconds after the ignition switch is turned from the "ON" position to the "ACC" or "LOCK" position.
- Immediately after the key is pulled out.

If the indicator light does not blink in the above conditions, it may indicate that immobilizer system may be malfunctioning. Contact your nearest SUBARU dealer immediately.

In the event that an unauthorized key (for example, an unauthorized duplicate) is used, the security indicator light illuminates. For details about the immobilizer system, refer to "Immobilizer"  2-2.

NOTE

- **The security indicator light remains off in the following conditions. It means that the matching of the ID code is completed and the immobilizer system is deactivated, and it does not indicate a malfunction.**

Models with "keyless access with push-button start system":

- while the engine is running
- the push-button ignition switch

has been turned to the "ON" or "ACC" position and the driver's door has not been opened or closed

Models without "keyless access with push-button start system":

- while the engine is running
- for approximately 60 seconds after the ignition switch is turned from the "ON" position to the "ACC" or "LOCK" position
- when the ignition switch is in the "ON" position.

- **Even if a malfunction occurs, such as the security indicator light flashes irregularly, it will not affect the functionality of the immobilizer system.**

■ SI-DRIVE indicator (if equipped)

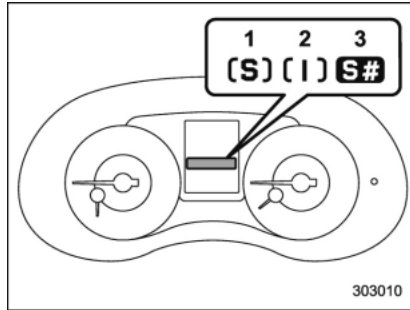

- 1) Sport (S) mode
- 2) Intelligent (I) mode
- 3) Sport Sharp (S#) mode

This indicator shows the current SI-DRIVE mode.

For details of SI-DRIVE mode, refer to “SI-DRIVE (STI)” [7-28](#) or “SI-DRIVE (except STI: CVT models)” [7-30](#).

■ Shift-up indicator (STI) ▲

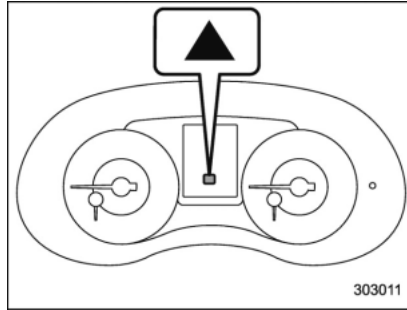

While driving, this indicator appears and informs the driver about the upshift timing for fuel-efficient driving.

The shift-up indicator can be activated or deactivated.

Refer to “Gear Position Indicator Setting (MT models)” [3-44](#).

■ Select lever/gear position indicator (CVT models)

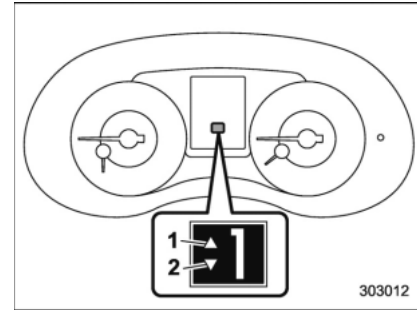

- 1) Upshift indicator
- 2) Downshift indicator

This indicator shows the position of the select lever.

For models with manual mode, when the manual mode is selected, the gear position indicator (which shows the current gear selection) and the upshift/downshift indicator light up. Refer to “Continuously variable transmission” [7-23](#).

For models with SI-DRIVE, the upshift/downshift indicators are switched off while the Sport Sharp (S#) mode is selected.

■ Turn signal indicator

These lights show the operation of the turn signal or lane change signal.

If the indicator lights do not blink or blink rapidly, the turn signal bulb may be burned out. Replace the bulb as soon as possible. Refer to "Replacing bulbs"  11-43.

■ High beam indicator light

This light shows that the headlights are in the high beam mode.

This indicator light also illuminates when the headlight flasher is operated.

■ Cruise control indicator

This indicator appears when the cruise control main button is pressed to activate the cruise control function. For details, refer to "To set cruise control"  7-48.

CAUTION

If the CHECK ENGINE warning light/malfunction indicator light illuminates, the cruise control indicator flashes at the same time. At this time, avoid driving at high speed

and have your vehicle inspected at a SUBARU dealer as soon as possible.

■ Cruise control set indicator

This indicator appears when vehicle speed has been set to use the cruise control function. Refer to "To set cruise control"  7-48.

■ Automatic headlight beam leveler warning light (models with LED headlights)

This light illuminates when the automatic headlight beam leveler does not operate normally.

If this light illuminates while driving or does not turn off approximately 3 seconds after turning the ignition switch to the "ON" position, have your vehicle inspected at your SUBARU dealer.

■ Front fog light indicator light (if equipped)

This indicator light illuminates while the front fog lights are illuminated.

■ Headlight indicator light

This indicator light illuminates under the following conditions.

- when the light switch is turned to the "D" or "D" position
- when the light control switch is in the "AUTO" position and the headlights illuminate automatically

■ Driver's control center differential auto indicator (STI)

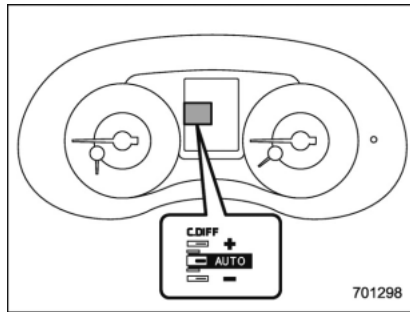

This indicator functions while the ignition switch is "ON". When it appears, it indicates that the driver's control center differential is set to the auto mode. It disappears when the driver's control center differential is set to the manual

mode. For details, refer to “Driver’s Control Center Differential (C.DIFF/DCCD) (STI)” 7-19.

▼ **Driver’s control center differential auto [+] indicator (STI)**



When the AUTO [+] mode is set, the AUTO [+] indicator appears.

For details, refer to “Driver’s Control Center Differential (C.DIFF/DCCD) (STI)” 7-19.

▼ **Driver’s control center differential auto [-] indicator (STI)**



When the AUTO [-] mode is set, the AUTO [-] indicator appears.

For details, refer to “Driver’s Control Center Differential (C.DIFF/DCCD) (STI)” 7-19.

■ **Driver’s control center differential indicator and warning (STI)**

▼ **Indicator**

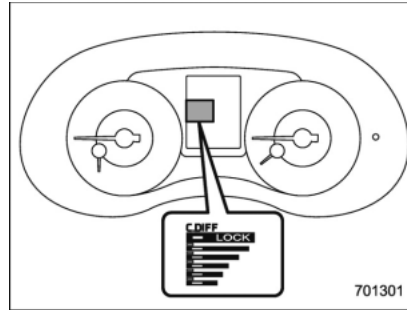

When you select the manual mode of the driver’s control center differential, the initial limited slip differential (LSD) torque that is currently selected for the center differential is indicated by the illumination of these indicator.

▼ **Warning indicator**

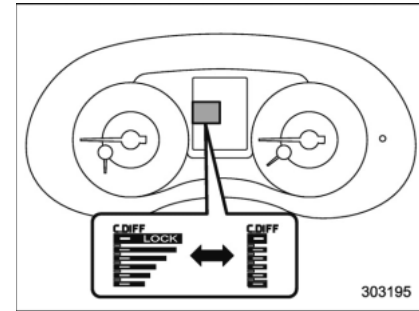

All the indicators will flash in the event that the driver’s control center differential has a malfunction. Have the vehicle inspected by your SUBARU dealer. For details, refer to “Driver’s Control Center Differential (C.DIFF/DCCD) (STI)” 7-19.

If a malfunction occurs in the vehicle (for example, when the rear differential oil temperature warning light illuminates or the AWD warning light blinks), all of the indicators may disappear and the setting value for the initial limited slip differential (LSD) torque of the driver’s control center differential (C.DIFF/DCCD) may be cancelled. However, it does not indicate a malfunction of the C.DIFF/DCCD itself.

■ **REV indicator light (STI)**



This indicator light illuminates when the engine speed reaches the level that was previously set. This indicator light also flashes when the tachometer needle enters the red zone. For details, refer to “REV indicator light and buzzer (STI)” 3-12.

Multi information display

 **WARNING**

Always pay adequate attention to safe driving when operating the multi information display while the vehicle is in motion. When operation of the multi information display interferes with your ability to concentrate on driving, stop the vehicle before performing operations on the screen. Also, do not concentrate on the display while driving. Doing so may cause you to look away from the road and could result in an accident.

Various information will be shown on the multi information display. Also, a warning message will appear on the display if a malfunction, etc. is detected. In addition, several settings for the displayed content can be performed.

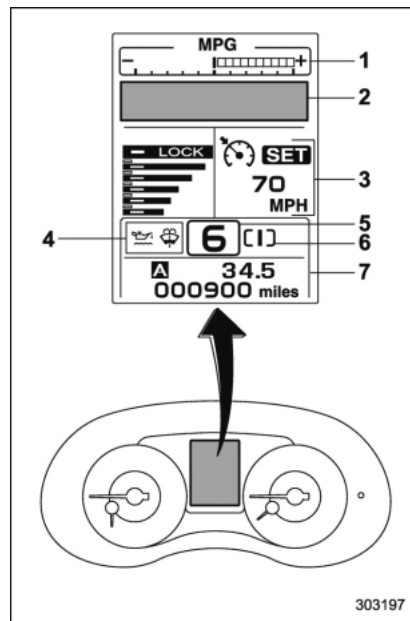

Multi information display

- 1) ECO gauge (refer to “ECO gauge” 3-11.)
- 2) Warning screen (refer to “Warning screen” 3-36.)/Basic screen (refer to “Basic screens” 3-41.)
- 3) Cruise control information display/
C.DIFF/DCCD indicator

303197

- 4) Warning indicator
- 5) Select lever/gear position indicator (refer to "Select lever/gear position indicator (CVT models)" 3-31.)
- 6) SI-DRIVE indicator light (refer to "SI-DRIVE indicator" 3-31.)
- 7) Odometer (refer to "Odometer" 3-9./ double trip meter (refer to "Double trip meter" 3-9.)

■ Basic operation

By operating "▲" or "▼" of the control switch, the screens and selection items can be switched. When the "I/SET" switch is pulled toward you, the item can be selected and set.

If there are some useful messages, such as vehicle information, warning information, etc., they will interrupt the current screen, and appear on the display accompanied by a beep. If such a screen is displayed, take proper action according to the message shown on the screen.

■ Welcome screen

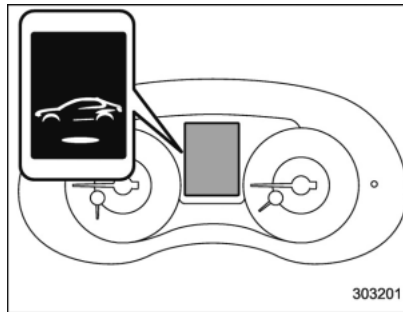

When the door is unlocked, and the driver's door is opened and then closed, the welcome screen will appear for approximately 20 seconds.

NOTE

- Once the welcome screen appears, it takes a certain period of time to display it again.
- The welcome screen will disappear when the ignition switch is turned to the "ON" position while the welcome screen is displayed.
- If any of the doors is opened while the welcome screen is displayed, the door ajar warning will appear.
- The welcome screen can be set to on or off. For details, refer to "Welcome

Good-bye Screen" 3-44.

■ Good-bye screen

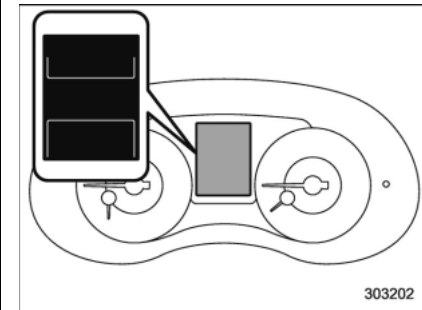

If the ignition switch is turned to the "LOCK"/"OFF" position, the "Good-bye" screen will appear for approximately 3 seconds.

■ Warning screen

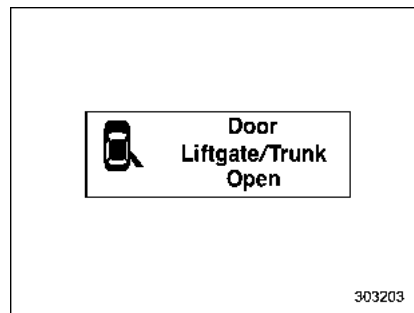

Example of warning

If a warning or a malfunction is detected, a message will appear. Take the appropriate actions based on the messages indicated.

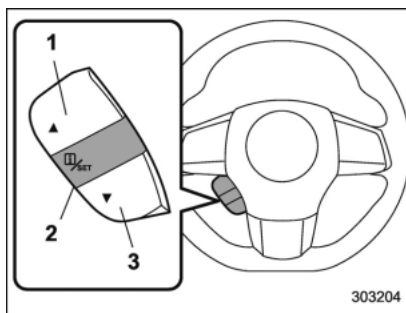









Control switch

- 1) Up (select)
- 2) **I**/SET (enter)
- 3) Down (select)











The warning screen will return to the original screen after a few seconds. While the "**I**" information reminder is on the display, it may be possible to display the warning screen again. To recall the message marked with "**I**" on the display, pull the "**I**/SET" switch on the steering wheel toward you.







▼ Items of display message (for warning message)

Item	Icon	"I" information reminder	Refer to page
Seatbelt warning for driver's seat and front passenger's seat		Red	3-13
SRS airbag system malfunction warning		Red	1-56, 3-15
Engine warning		Yellow	3-16
Coolant temperature high warning		Red	3-11, 9-11
Engine oil level warning (except STI)		Yellow	3-17
Transmission fluid temperature high warning (CVT models)	AT OIL TEMP	Yellow or red*	3-18
Transmission control system malfunction warning (CVT models)		Yellow	3-18
Low tire pressure warning (U.S.-spec. models)		Yellow	3-18
TPMS system malfunction warning (U.S.-spec. models)		Yellow	3-18

*: The displayed color varies depending on individual countries.







3-38 *Instruments and controls/Multi information display*

Item	Icon	"I" information reminder	Refer to page
ABS system malfunction warning	ABS / 	Yellow	3-20
Vehicle Dynamics Control system malfunction warning		Yellow	3-23
Parking brake applied warning	BRAKE / 	Red	3-20
EBS system malfunction warning	BRAKE / 	Red	3-21
Brake fluid level warning	BRAKE / 	Red	3-21
Low fuel warning		Yellow	3-21
Windshield washer fluid level warning		Yellow	3-17
Hill start assist system malfunction warning		Yellow	3-22
Door/trunk lid open warning		—	3-22
AWD system malfunction warning (if equipped)	AWD	Yellow	3-22
Electric power steering system malfunction warning (except STI)		Red	3-22

Item	Icon	"I" information reminder	Refer to page
Automatic headlight beam leveler system malfunction warning (models with LED headlights)		Yellow	3-32
LED low beam headlight system malfunction warning (if equipped)		Yellow	3-23
The keyless access with push-button start system malfunction warning*		—	—
Low battery warning of the access key*		—	3-26
Driver's control center differential system malfunction warning		Yellow	3-32
Deactivation of switching SI-DRIVE mode		—	7-28, 7-30

*: Models with keyless access with push-button start system

▼ Items of display message (for operation and vehicle condition)

Item	Icon	"i" information reminder	Refer to page
Deactivation of the selection of the SI-DRIVE Sport Sharp (S#) mode when the engine is cold	—	—	7-28, 7-30
Pedal operation for starting engine		—	7-12
Select lever into "P" operation		—	—
Access key warning* (The vehicle was driven while the access key is not inside the vehicle.)		—	3-26
Push-button ignition switch without "OFF" warning*	—	—	3-26
Access key lock-in warning*		—	3-26
Emergency operation of push-button ignition switch*		—	9-16
Release operation for steering lock*		—	3-26
Power save function operation*	—	—	2-14
Key in the ignition switch reminder (if equipped)	—	—	3-5
Headlights ON warning	—	—	3-98

*: Models with keyless access with push-button start system

Basic screens

By operating the “▲” or “▼” switch on the steering wheel, you can change the screen that is always displayed.

Default screen:

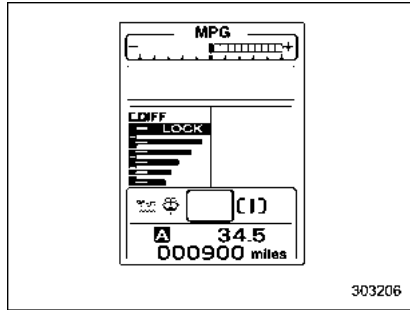

Journey time screen:

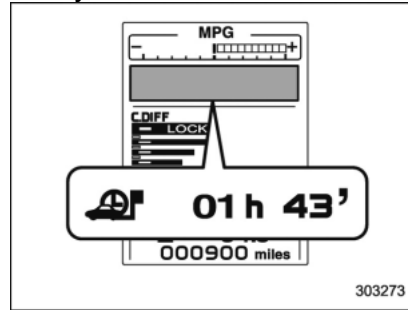

This screen displays the journey time (the time that has elapsed since the ignition switch was turned to the “ON” position).

Digital speedometer:

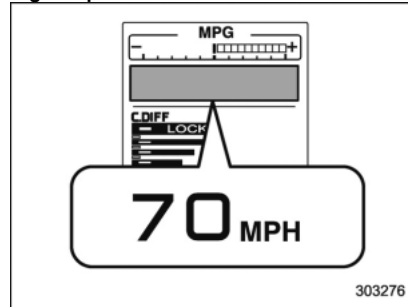

SI-DRIVE mode screen:

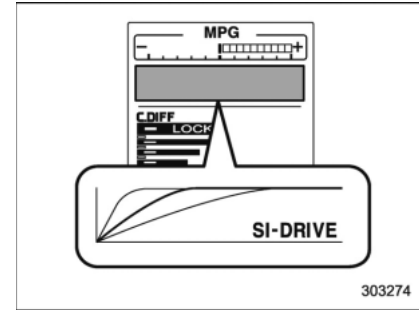

This screen indicates the current SI-DRIVE mode with its throttle angle.

Menu screen entering screen:

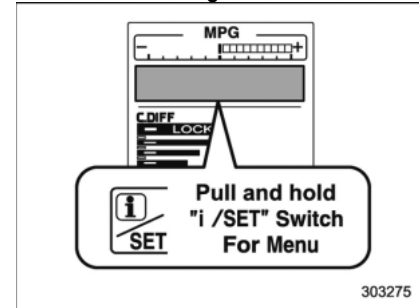

While this screen is selected, pull and hold the “i/SET” switch to enter the menu screen.

■ **Menu screens**

Pull and hold the “**I**/SET” switch to enter the menu screens when all of the following conditions are satisfied.

- The vehicle has been completely stopped.
- The select lever is in the “P” position (CVT models).
- The shift lever is in the neutral position (MT models).
- The menu screen entering screen is selected.

The menu list is as follows.

Top menu	Menu option	Possible settings	Initial settings
Screen Settings	Welcome Good-bye Screen	On or Off	On
	Gauge Initial Movement	On or Off	On
	Gear Position Indicator Setting (MT models)	On or Off	On
	Languages	Select the display language.	The default language settings vary depending on individual countries. (For U.S. models: English)
REV settings (STI)	REV Indicator Light	On or Off	Off
	REV Alarm Level Engine Speed	2000 rpm - RED ZONE	2000 rpm
	REV Buzzer	On or Off	Off
Default Settings	—	Yes or No	—

By operating the “▲” or “▼” switch on the steering wheel, you can select the menu. Pull the “**I/SET**” switch to enter the selected menu.

NOTE

If you enter the “Return” menu, the system will return to the previous screen.

▼ Screen Settings

After entering the “Screen Settings” menu, select one of the following menus.

▽ Welcome Good-bye Screen

The welcome screen/good-bye screens can be activated or deactivated. Select “On” to activate the screens. Select “Off” to deactivate the screens.

▽ Gauge Initial Movement

The movement of the meter needles and gauge needles that occurs when the ignition switch is turned to the “ON” position can be activated or deactivated. Select “On” to activate. Select “Off” to deactivate.

▽ Gear Position Indicator Setting (MT models)

Display of the shift position indicator can be activated or deactivated. Select “On” to activate display of the shift position in-

dicator or “Off” to deactivate it.

▽ Languages

Operate the “▲” or “▼” switch on the steering wheel to display the preferred language. Then pull the “**I/SET**” switch to select the displayed language.

▼ REV settings (STI)

NOTE

If the setting of the REV Indicator Light is “Off”, the setting menus of the REV Alarm Level Engine Speed and the REV Buzzer are not displayed.

After entering the “REV settings” menu, select any of the following menus.

▽ REV Indicator Light

Display of the REV indicator light can be activated or deactivated. Select “On” to activate display of the REV indicator light or “Off” to deactivate it.

▽ REV Alarm Level Engine Speed

The alarm-level engine speed can be set (in 100 rpm steps) within the range from 2,000 rpm to the red zone.

▽ REV Buzzer

The REV buzzer can be activated or deactivated. Select “On” to activate the REV buzzer or “Off” to deactivate it.

▼ Default Settings

Select “Yes” to use the menu screen to restore customized settings to the factory default settings. Select “No” to return to the previous screen without restoring to the factory default settings.

Multi function display

WARNING

Always pay adequate attention to safe driving when operating the multi function display while the vehicle is in motion. When operation of the multi-function display is disturbing your awareness and ability to concentrate on driving, stop the vehicle in a safe place before performing operations on the screen. Also, do not concentrate on the display while driving. Doing so may cause you to look away from the road and could result in an accident.

The multi function display has the following functions.

Description	Page
Displays useful messages, such as warning information, etc.	3-48
Displays basic screens (e.g. fuel consumption screen, etc.)	3-49
Sets and adjusts maintenance notification	3-78
Registers driving history	3-81
Sets and customizes car operation	3-82

Also, the multi function display can also be used to set and initialize the multi function display itself.

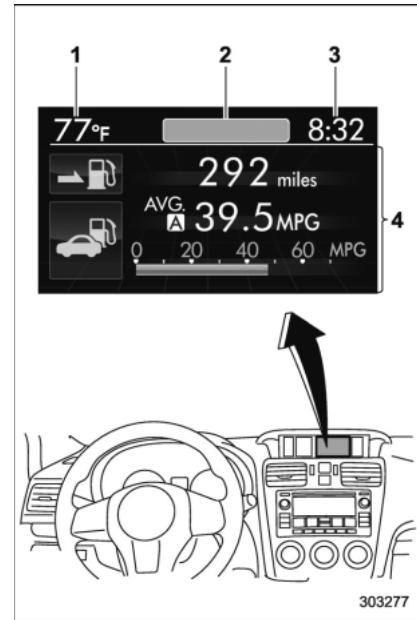

Multi function display

- 1) Outside temperature indicator
- 2) Top display (For the display setting, refer to "Top display setting" 3-69.)
- 3) Clock
- 4) Driving information display (For the displayed contents, refer to "Basic screens" 3-49.)

■ Basic operation

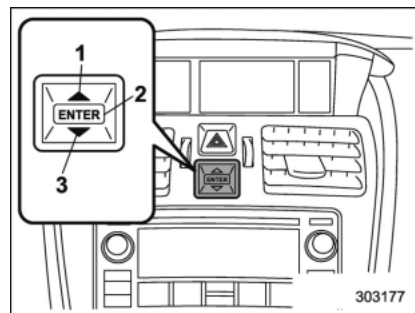

Control switch

- 1) Up (select)
- 2) ENTER (push)
- 3) Down (select)

By operating “▲” or “▼” of the control switch, the screens and selection items can be switched. When the ENTER button is pushed, the item can be selected and set.

■ Welcome screen

When the door is unlocked and the driver's door is closed, the welcome screen will appear for a short time.

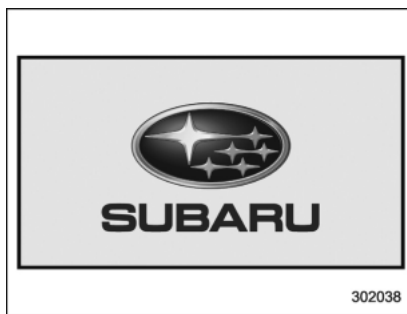

NOTE

- The welcome screen will disappear when the ignition switch is turned to the “ON” position while the welcome screen is displayed.
- The welcome screen can be set to on or off. For details, refer to “Bypass screen setting” 3-75.
- For a certain period of time after the welcome screen has once appeared, it may not appear again even when the driver's door is closed again. This does not indicate a malfunction.

■ Date screen

If you have set the date and time in the selection screen, after the welcome screen is displayed, the current date will be displayed for a certain period of time. If “On/Off setting” is set to “On” in the “Maintenance settings”, the date will be displayed after the self-check screen.

▼ Birthday/anniversary screen



Example of notification on an anniversary

If you have set a birthday or anniversary, after the date screen is displayed, the notification (reminder) will be displayed for a certain period of time from 7 days prior to the set date.

NOTE

- Displaying the birthday/anniversary screen can be set to on or off. Refer to “Bypass screen setting” 3-75.
- Up to five items can be set for birthdays and anniversaries respectively. Refer to “Selection screen” 3-56.

Ending screen

If “Eco Summary” is set to “On” in the “Bypass screen setting”, the “Fuel consumption results screen” will be displayed before the screen turns off when the ignition switch is turned to the “LOCK”/“OFF” position.

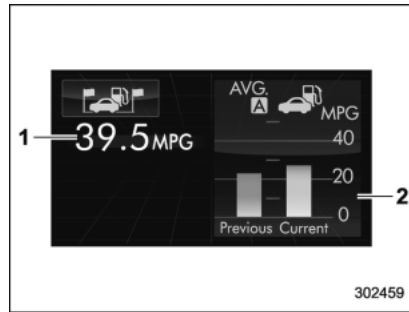
**Fuel consumption results screen**

- 1) The average fuel consumption for the entire driving distance, from when the ignition switch was turned to the “ON” position to when it was turned to the “LOCK”/“OFF” position.
- 2) This display shows the average rate of fuel consumption since the trip meter was last reset. It displays the average fuel consumption corresponding to the A trip meter mileage or the one corresponding to the B trip meter mileage.

Self-check screen

When the ignition switch is turned to the “ON” position, the vehicle self-check will be performed. The screens corresponding to the following items will appear one after another for several seconds each.

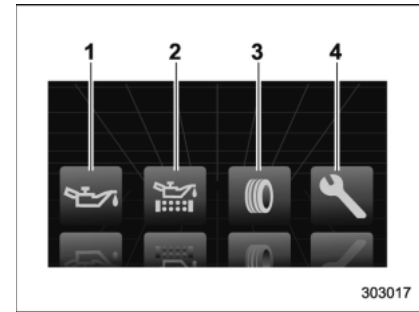

- 1) Engine oil: Checks the interval of engine oil replacement.
- 2) Oil filter: Checks the interval of oil filter replacement.
- 3) Tires: Checks the interval of tire rotation.
- 4) Inspection and maintenance: Checks the interval of inspection and maintenance.

When the checks are performed, the color of the icon corresponding to the checked item will turn green.

If there is no warning message, the self-check will complete without notification.

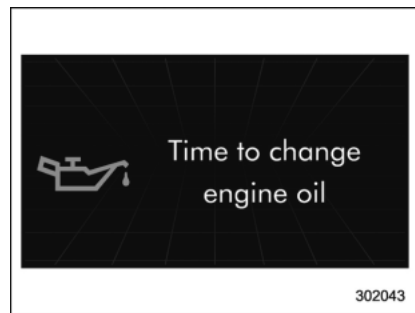

Example of notification

If there is a warning message or a maintenance notification, the color of the icon corresponding to the item will turn yellow and the warning message or the maintenance notification will be displayed. Take the appropriate actions based on the messages indicated.

NOTE

- The self-check screen can be set to on or off. The default setting is off. For details, refer to "On/Off setting" 3-79.
- After performing the maintenance, change the setting of the corresponding maintenance item. For details, refer to "Maintenance settings" 3-78.
- The maintenance notification screen will be displayed under either of the

following conditions.

- The period of time remaining until the registered notification date is 15 days or less.
- The total driving distance remaining until the registered notification distance is approximately 311 miles (500 km) or less.
- The maintenance notification screen will be displayed until either of the following conditions is satisfied.
 - The period of time passed after the registered notification date is 15 days or more.
 - The total distance driven after the registered notification distance is approximately 311 miles (500 km) or more.

■ Interruption screen

Useful messages, such as reminder information, vehicle information, warning information, etc. may interrupt the current screen and appear on the display accompanied by a beep. Take proper action according to the message.

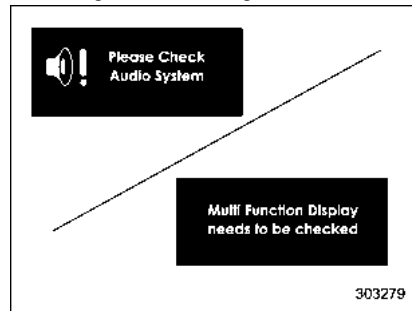

The warning screen will return to the original screen after a few seconds.

■ Basic screens

These are the basic screens of the multi function display.

Item	Page
Information bar	3-49
Boost pressure + accelerator opening ratio screen	3-50
Fuel consumption screen	3-51
ECO history screen	3-51
Vehicle activation status screen	3-52
Triple meter screen	3-53
Guidance screen	3-53
Clock/calendar screen	3-54
Audio screen (if equipped)	3-54

By operating the “▲” or “▼” of the control switch, you can switch the screen that is always displayed. Also, when the **ENTER** button is pushed and held, the selection screen can be displayed. For details about the selection screen, refer to “Selection screen” 3-56.

▼ Information bar

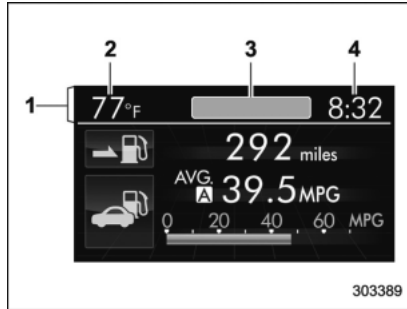

- 1) Information bar
- 2) Outside temperature indicator
- 3) Top display
- 4) Clock

While the ignition switch is in the “ACC” or “ON” position, the outside temperature indicator, clock, etc. will be shown on the information bar.

▽ Outside temperature indicator

This displays the outside temperature between -40°F (-40°C) and 122°F (50°C).



Icy road surface warning screen

When the outside temperature becomes 37°F (3°C) or less, the icy road surface warning screen interrupts to inform the driver that the road surface may be frozen.

NOTE

- The outside temperature indicator shows the temperature around the sensor. Therefore, the temperature indication may differ from the actual outside air temperature.
- The icy road surface warning screen should be treated only as a guide. Be sure to check the condition of the road surface before driving.
- Once the icy road surface warning screen is displayed, it will not be displayed again unless the outside

temperature has increased to 41°F (5°C) or higher.

▽ **Top display**

One of the following items can be displayed on the top display.

- Average fuel consumption corresponding to the driving distance of each trip meter
- Current fuel consumption (This may not be displayed when driving at a low speed.)
- Driving range on remaining fuel

For details about the setting of the top display, refer to “Top display setting” 3-69.

NOTE

The driving range on the remaining fuel is calculated using the average fuel consumption of the last 19 miles (30 km) driven. This value may be different from the values calculated using the average fuel consumption corresponding to the driving distance of each trip meter or the current fuel consumption.

▽ **Clock**

The clock can be displayed in either 12-hour display or 24-hour display. For details about the setting, refer to “Current date

and time setting” 3-60.

NOTE

If the vehicle battery is disconnected, the clock shown in the information bar will be reset. Set the time again after the vehicle battery is connected. For details about the setting, refer to “Top display setting” 3-69.

▼ **Boost pressure + accelerator opening ratio screen**

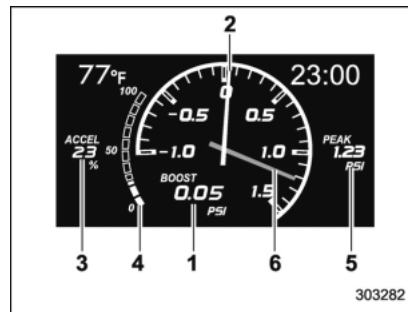

- 1) Boost pressure (digital display)
- 2) Boost pressure (analog display)
- 3) Accelerator opening ratio (digital display)
- 4) Accelerator opening ratio (analog display)
- 5) The peak value of the boost pressure (digital display)
- 6) The peak value of the boost pressure (analog display)

This screen displays the boost pressure, the accelerator opening ratio and the peak value of the boost pressure in both digital and analog format. Pressing the **ENTER** button in the “Boost pressure + accelerator opening ratio screen” moves to a screen where you can reset the peak value of the boost pressure.

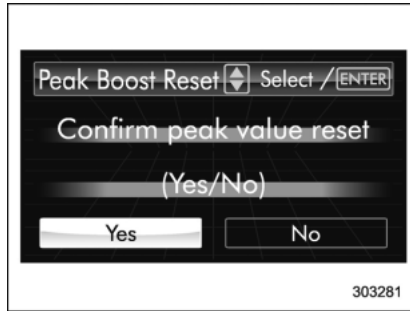

To reset the peak value, select “Yes”. If you select “No”, the current peak value is still kept.

▼ Fuel consumption screen

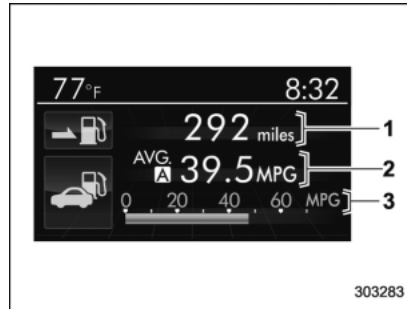

- 1) Driving range on remaining fuel
- 2) Average fuel consumption corresponding to the driving distance of each trip meter
- 3) Current fuel consumption

The displayed location can be customized. For details, refer to “Fuel consumption screen setting” 3-70.

▼ ECO history screen

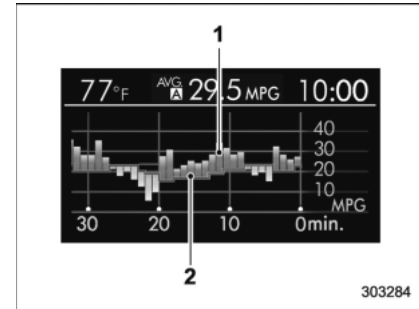

- 1) Average fuel consumption per unit time (bar graph)
- 2) Average fuel consumption corresponding to the driving distance of each trip meter (red line)

This screen displays the fuel economy history for the vehicle using a bar graph.

The horizontal scale represents the past time range and the vertical scale represents the fuel consumption. The green bars show driving with good fuel economy and the yellow bars show driving with poor fuel economy.

The time range of the history can be set. The width of the bar graph is adjusted as follows depending on the set time range.

3-52 Instruments and controls/Multi function display

Time range	Width of bar graph
30 minutes	1 minute
60 minutes	2 minutes
120 minutes	4 minutes

For details about the setting, refer to "Economy history setting" 3-71.

▼ Vehicle activation status screen

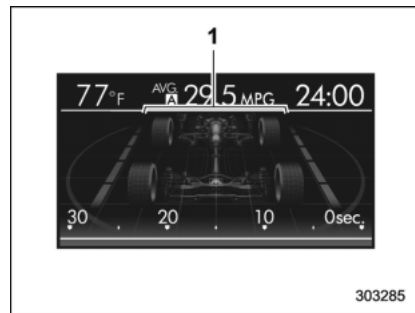

When the vehicle stops

- 1) Steering axle

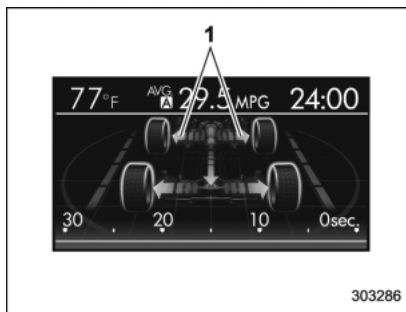

When the vehicle is being driven regularly

- 1) Power train (illuminated in blue)

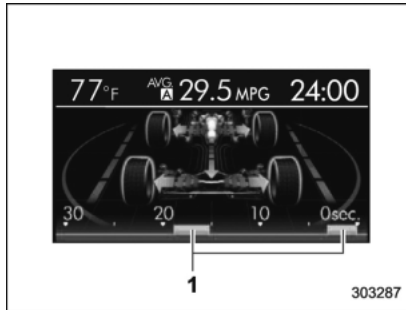

When the Vehicle Dynamics Control system starts to activate, the tires illuminate in yellow.

- 1) History of Vehicle Dynamics Control system activation

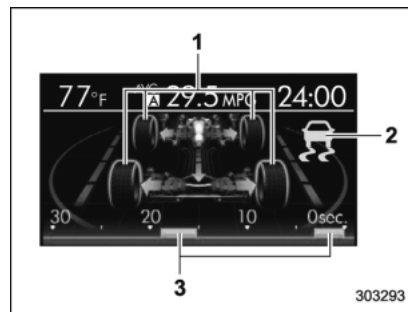

When the Vehicle Dynamics Control system activates, the tires illuminate in yellow and the Vehicle Dynamics Control system operating indicator flashes.

- 1) Activation status of the ABS (Anti-lock Brake System)
- 2) Vehicle Dynamics Control system operating indicator (flashing in yellow)
- 3) History of Vehicle Dynamics Control system activation

▼ **Triple meter screen****Triple meter screen (display example)**

This screen displays up to three optional pieces of information that can be selected from the following items.

The items shown in the triple meter screen can be changed. For details, refer to "Triple meter setting" 3-73.

Item	Details
	Average vehicle speed (Average vehicle speed for the entire driving time from when the trip meter was reset)
	Lifetime fuel consumption
	Engine oil temperature (except STI)
	Accelerator opening ratio
	Journey distance (the distance that has been driven since the ignition switch was turned to the "ON" position)
	Average fuel consumption for the entire driving distance from when the ignition switch was turned to the "ON" position
	Boost pressure

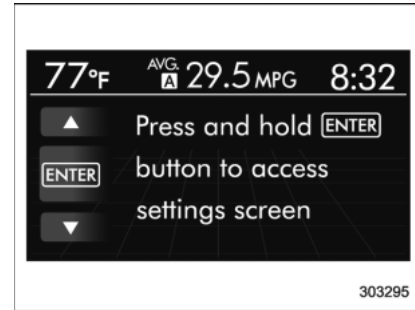
▼ **Guidance screen**

When the 'ENTER' button is pushed and held, the selection screen can be displayed.

The displayed contents can be set or customized from the selection screen. For details, refer to "Selection screen" 3-56.

▼ Clock/calendar/screen OFF



Clock (analog format)



Clock (digital format)

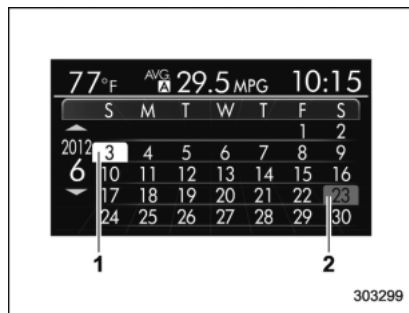

Calendar

- 1) Today's date
- 2) Birthday/Anniversary

In addition to the clock/calendar, the outside temperature and average fuel consumption can also be displayed.

You can select clock (analog format), clock (digital format) or calendar. The clock/calendar can also be set so that it is not displayed. For details, refer to "Clock/calendar screen setting" 3-74.

▼ Audio screen (if equipped)

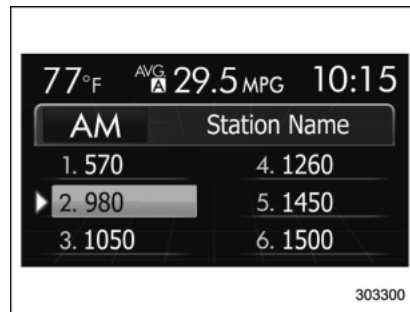

Example of the audio screen

This screen displays the current audio mode (FM mode, AM mode, etc.) and the following items.

When FM mode or AM mode is selected:

- Broadcasting station on-air
- Frequency on-air
- HD indicator* (type B)

*: When the HD radio is set to ON and gathering digital data or when receiving a live broadcast such as a ball game, the indicator will illuminate in gray. When the HD radio is set to ON and is receiving a broadcast from a HD broadcasting station, the indicator will illuminate in yellow.

Press the “LIST” button on the audio set to display the preset frequencies of the broadcasting stations.

When CD mode is selected:

- Track number
- Album title (while playing a CD-Text)
- Folder title (while playing MP3/WMA/AAC format CDs)
- Artist title
- Song title

While playing an MP3/WMA/AAC format track, press the “LIST” button on the audio set to display a list of the folder titles for 8 seconds.

When USB mode is selected:

- Folder title
- Artist title
- Song title

Press the “LIST” button on the audio set to display a list of the folder titles.

When iPod® mode is selected:

- Album title
- Artist title (while playing music or an audiobook)
- Song title (while playing music or a podcast)
- Audiobook title (while playing an audiobook)

- Podcast date (while playing a podcast)

Press the “LIST” button on the audio set to display the titles of playlists etc.

When Bluetooth® audio mode is selected:

- Album title
- Artist title
- Song title

When AUX mode is selected:

“No Device” (only when you select AUX mode while an external device is not connected)

When satellite radio mode is selected:

- Broadcasting station on-air
- Artist title
- Song title

Press the “LIST” button on the audio set to display the preset channel.

Hands-free system:

- Name of the person you are calling (voice tag)
- Phone number of the person you are calling
- Length of call

■ Selection screen

When the **ENTER** button is pushed and held, the setting screen for each menu can be displayed. Select the preferred menu by operating the “▲” or “▼” switch.

Top menu	Menu option	Description	Initial setting	Page	
Time/Date	Time/Date	Set and adjust the time and date. 12h or 24h format can be selected.	1/1/2013 12 h 13:00	3-60	
	Birthday	Set a birthday. (max. 5)	—	3-61	
	Anniversary	Set an anniversary day. (max. 5)	—	3-63	
	Daylight Saving Time	Turn the daylight saving time on or off	Off	3-66	
	Go Back	Return to the top menu.	—	—	
Display	Contrast	Adjust the contrast.	+5 ↔ -5	0	3-67
	Screen Off	Turn the screen on or off.	On or Off	Off	3-67
	Beep	Adjust the beep sound volume.	High, Low or Off	High	3-68
	Go Back	Return to the top menu.	—	—	

Top menu	Menu option	Description		Initial setting	Page
Screen Setting	Top Display	Set and customize the top display information contents.	Avg Cons, Inst Cons, Range or Off	Avg Cons	3-69
	Cons	Customize the fuel consumption information display.		Upper part: Driving range, lower part: Fuel consumption	3-70
	Eco History	Set and customize the time of logging fuel consumption history.	30 min, 60 min or 120 min	30 min	3-71
	Triple Meter	Set and customize the triple meter.		Left: Lifetime fuel consumption, center: Average fuel consumption, right: Accelerator opening ratio	3-73
	Clock	Select the clock format.	Analog clock, Digital clock, Calendar or Off	Analog clock	3-74
	Bypass Screen	Set the bypass screen for each item.	On or Off	Welcome screen: On Eco Summary: Off Birthday Reminder: On Anniversary Reminder: On	3-75
	Rear View Camera	Set the delayed-off function of the rear view camera image display.	On or Off	Off	3-76
	Languages	Select the display language.	English or French or Spanish (U.S.-spec. models only)	The default language settings vary depending on individual countries.	3-77
	Go Back	Return to the top menu.		—	—

3-58 *Instruments and controls/Multi function display*

Top menu	Menu option	Description		Initial setting	Page
Maintenance	Engine Oil	Set and adjust the oil maintenance notification date.		The default values for the maintenance settings vary depending on individual countries.	3-78
	Oil Filter	Set and adjust the oil filter maintenance notification date.			3-79
	Tires	Set and adjust the tire maintenance notification date.			3-79
	Maintenance Schedule	Set and adjust the vehicle maintenance notification date.			3-79
	On/Off	Turn on or off the self-check screen that is activated when the ignition switch is turned to the "ON" position.	On or Off	Off	3-79
	Clear All Settings	Clear all items to the factory default settings.	Yes or No	—	3-80
	Go Back	Return to the top menu.		—	—
Driving History	Set	Register and overwrite the driving record.		—	3-81
	Go Back	Return to the top menu.		—	—
Car Setting	Audible Signal	Set the audible signal.	On or Off	On	3-83
	Hazard Warning Flasher	Set the hazard warning flasher.	On or Off	On	3-84
	Defogger	Set and customize the operation of the defogger.	15 minutes or Continuous	15 minutes	3-85
	Interior Light	Set and customize the interior light off delay timer.	10, 20, 30 seconds or Off	30 seconds	3-86
	Auto Light Sensor (if equipped)	Set and customize the sensitivity of the auto light sensor.	Low, Mid, High or Max	Mid	3-87
	Keyless Access Setting Driver's Door Unlock (if equipped)	Set and customize the keyless access function.	Driver's Door Only, All	Driver's Door Only	3-88
	Go Back	Return to top menu.		—	—

Top menu	Menu option	Description		Initial setting	Page
Initialize	Reset to Defaults	Reset all settings to the default settings.	Yes or No	—	3-90
	Lifetime Fuel Cons Reset	Clear logged lifetime fuel consumption data.	Yes or No	—	3-91
	Go Back	Return to the top menu.		—	—
Go Back	—	Return to the top menu.		—	—

■ Date and time settings

The items in the date and time settings can be set. To change the items, operate the “▲” or “▼” switch.

NOTE

- The “Date” item must be set to display the “Birthday”, “Anniversary” and notifications for vehicle maintenance.
- The “Birthday” and “Anniversary” items can be entered after the “Date” item has been set.
- Dates that do not exist in the Gregorian calendar cannot be set (for example, April 31).

▼ Preparation for date setting

1. Turn the ignition switch to the “ON” position.
2. Push and hold the **ENTER** button to show the selection screen.

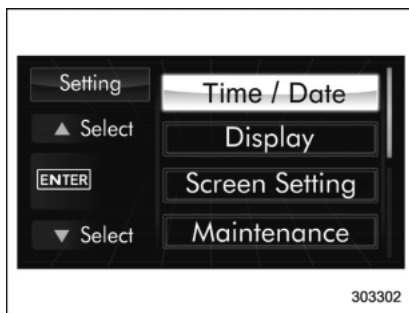

3. After the selection screen is displayed, operate the “▲” or “▼” switch to show the “Date” item. Then, push the **ENTER** button.

▼ Current date and time setting

1. Perform the preparation steps according to “Preparation for date setting” ③-60.



2. Operate the “▲” or “▼” switch to select the “Date” item. Then push the **ENTER** button.

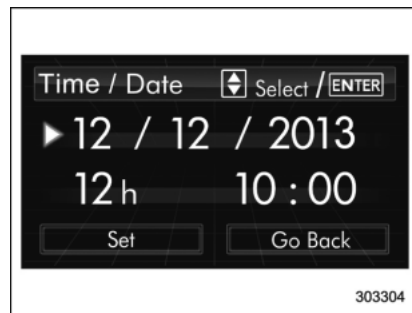

3. Select the item to set by operating the “▲” or “▼” switch. Then push the **ENTER** button.

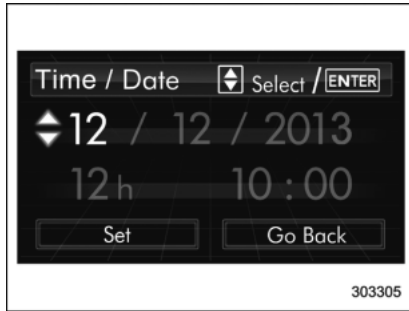

4. Select a number by operating the “▲” or “▼” switch. Then push the **ENTER** button. When “12 h” is selected, the clock will be set to a 12-hour display. When “24 h” is selected, the clock will be set to a 24-hour display.

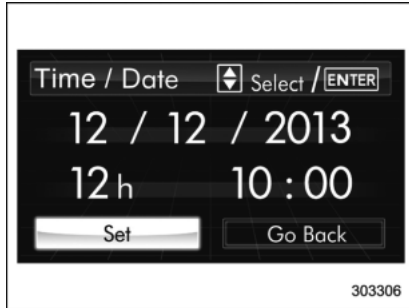

5. After entering the date and time, select “Set” by operating the “▼” switch and confirm the setting by pushing the **ENTER** button.



6. The system will notify you that the setting is complete.

▼ Birthday setting

1. Perform the preparation steps according to “Preparation for date setting” 3-60.



2. Operate the “▲” or “▼” switch to select the “Birthday” item. Then push the **ENTER** button.

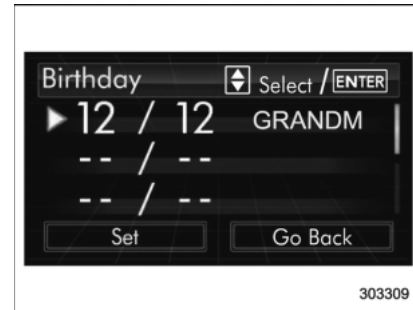

3. Select an entry in the list to set by operating the “▲” or “▼” switch. Then push the **ENTER** button.



4. The selected item will be shown. Push the **ENTER** button to set the selected item.



5. Select numbers by operating the "▲" or "▼" switch. Then push the **ENTER** button.

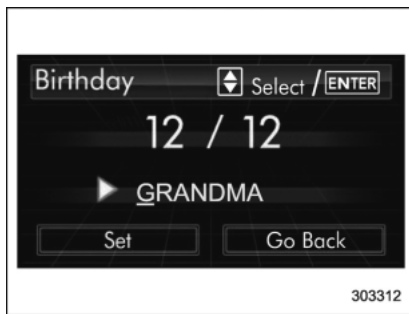

6. After entering the date by repeating step 5, you can enter the name.



7. Select characters by operating the "▲" or "▼" switch. Then push the **ENTER** button.

– You can select characters of the

English alphabet (upper case characters and lower case characters are available), eleven symbols or blank spaces.

– The word being edited will be displayed with an underline.

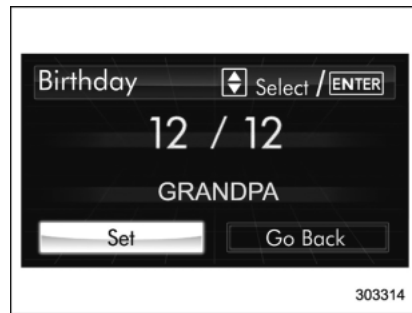

8. After entering the name by repeating step 7, select "Set" by operating the "▼" switch and confirm the setting by pushing the **ENTER** button.

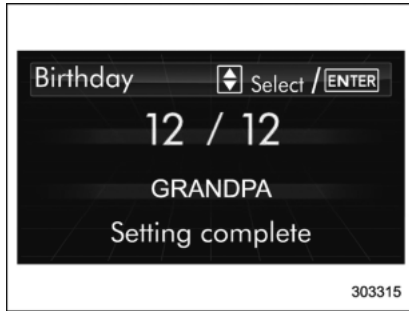

9. The system will notify you that the setting is complete.

If a birthday is approaching, the following screen will be displayed accompanied by a beep when the ignition switch has been turned to the "ON" position. This function can be set to on or off. For details, refer to "Bypass screen setting" 3-75.



From 1 to 7 days prior to the birthday



On a birthday (displayed in red)

NOTE

If "_ _" is selected for either the "Month" or "Day" item instead of numbers, the birthday notification will

be deactivated.

▼ Anniversary setting

1. Perform the preparation steps according to "Preparation for date setting" 3-60.



2. Operate the "▲" or "▼" switch to select the "Anniversary" item. Then push the ENTER button.

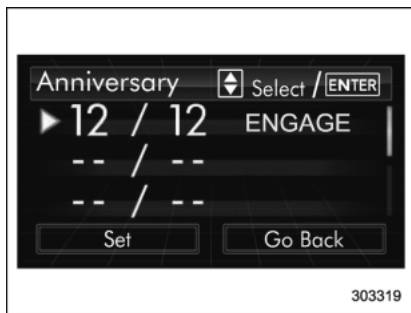

3. Select an entry in the list to set by operating the “▲” or “▼” switch. Then push the `ENTER` button.



4. The selected item will be shown. Push the `ENTER` button to set the selected item.



5. Select numbers by operating the “▲” or “▼” switch. Then push the `ENTER` button.



6. After entering the date by repeating step 5, you can enter the name.



7. Select characters by operating the “▲” or “▼” switch. Then push the `ENTER` button.

- You can select characters of the English alphabet (upper case characters and lower case characters are available), eleven symbols or blank spaces.
- The word being edited will be displayed with an underline.



8. After entering the name by repeating step 7, select "Set" by operating the "▼" switch and confirm the setting by pushing the **ENTER** button.

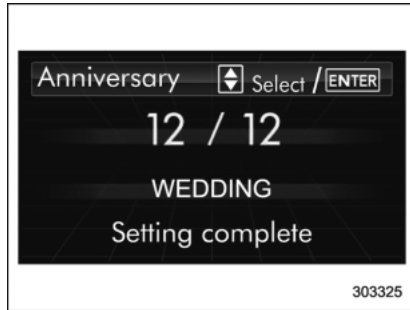

9. The system will notify you that the setting is complete.

If an anniversary is approaching, the following screen will be displayed accompanied by a beep when the ignition switch has been turned to the "ON" position. This function can be set to on or off. For details, refer to "Bypass screen setting" 3-75.

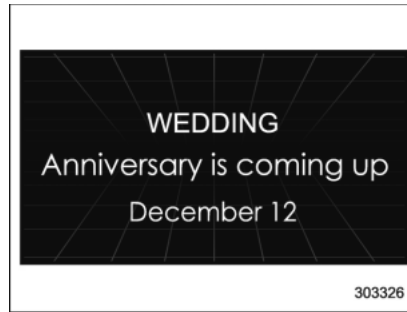

From 1 to 7 days prior to the anniversary



On an anniversary (displayed in orange)

NOTE

If " _ " is selected for either the "Month" or "Day" item instead of numbers, the anniversary notification will be deactivated.

▼ Clearing birthday or anniversary

1. Perform the preparation steps according to "Preparation for date setting" 3-60 and display "Birthday" or "Anniversary" on the screen.
2. Select the preferred birthday/anniversary.
3. When " _ " is selected for either the "Month" or "Day" item instead of numbers, the setting of "Birthday" or "Anniversary" will be cleared.

▼ Daylight saving time setting

1. Perform the preparation steps according to "Preparation for date setting" 3-60.



2. Operate the "▲" or "▼" switch to select the "Daylight Saving Time" item. Then push the **ENTER** button.



3. The current setting will be displayed. Push the **ENTER** button to enter the selection mode.

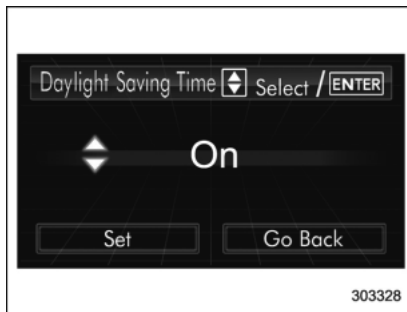

4. Select "On" or "Off" by operating the "▲" or "▼" switch. Then push the **ENTER** button.



5. Select "Set" by operating the "▼" switch, and confirm the setting by pushing the **ENTER** button.



6. The system will notify you that the setting is complete.

■ Image quality and volume settings

The image quality and volume settings can be adjusted. To change the items, operate the “▲” or “▼” switch.

▼ Preparation for image quality and volume settings

1. Turn the ignition switch to the “ON” position.
2. Push and hold the **ENTER** button to show the selection screen.

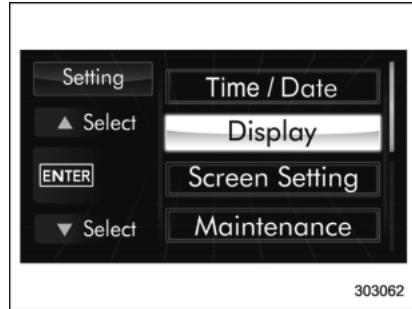

3. After the selection screen is displayed, operate the “▲” or “▼” switch to show the “Display” item. Then, push the **ENTER** button.

▼ Contrast setting

1. Perform the preparation steps according to “Preparation for image quality and volume settings” 3-67.

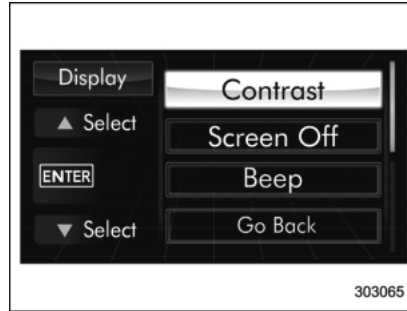

2. Operate the “▲” or “▼” switch to select the “Contrast” item. Then push the **ENTER** button.

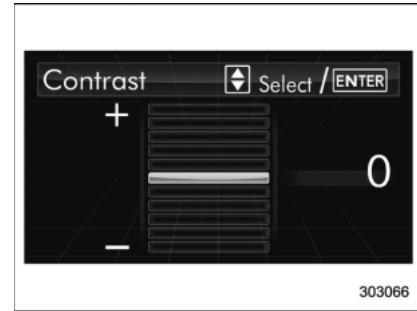

3. Select a contrast level by operating the “▲” or “▼” switch, and confirm the setting by pushing the **ENTER** button.

▼ Screen OFF setting

1. Perform the preparation steps according to “Preparation for image quality and volume settings” 3-67.

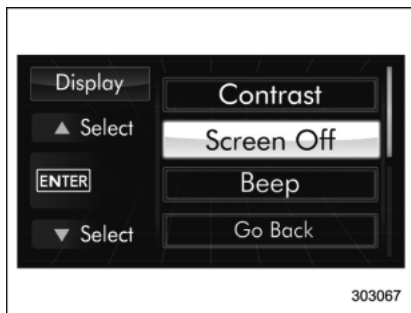

2. Operate the “▲” or “▼” switch to select the “Screen OFF” item. Then push the **ENTER** button.



3. Push the **ENTER** button once more.



4. The screen is turned off.

Restoring the screen

When the “▲”, “▼” or **ENTER** button is pushed after the ignition switch is turned to the “ON” position, the screen will be restored. The screen will be restored with the basic screen that was displayed when the screen was turned off. While the screen is off, a warning message will be displayed if necessary, but other screens will not be displayed.

▼ Beep volume setting

1. Perform the preparation steps according to “Preparation for image quality and volume settings” [☞](#) 3-67.

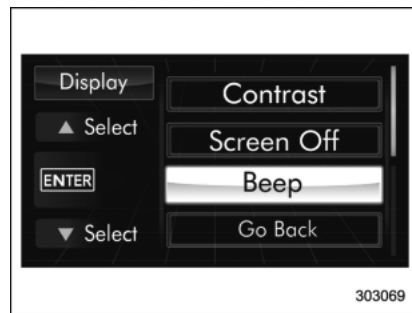

2. Operate the “▲” or “▼” switch to select the “Beep” item. Then push the **ENTER** button.



3. Push the **ENTER** button.



4. Select an item by operating the “▲” or “▼” switch. Then push the **ENTER** button.



5. Select “Set” by operating the “▼” switch, and confirm the setting by pushing the **ENTER** button.



6. The system will notify you that the setting is complete.

■ Screen settings

The items in screen settings can be set. To change the items, operate the “▲” or “▼” switch, and then push the **ENTER** button.

▼ Preparation for screen settings

1. Turn the ignition switch to the “ON” position.
2. Push and hold the **ENTER** button to show the selection screen.

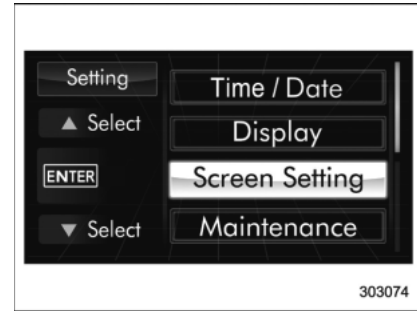

3. After the selection screen is displayed, operate the “▲” or “▼” switch to show the “Screen Setting” item. Then, push the **ENTER** button.

▼ Top display setting

1. Perform the preparation steps according to “Preparation for screen settings” 3-69.

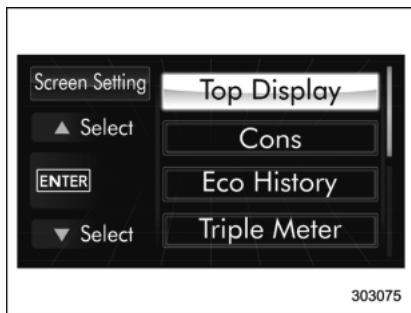

2. Operate the “▲” or “▼” switch to select the “Top Display” item. Then push the **ENTER** button.

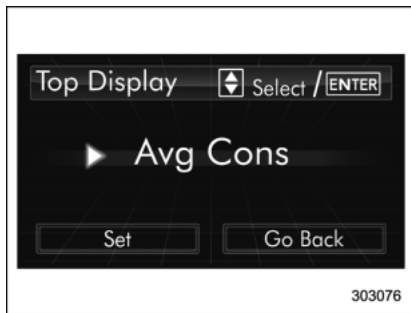

3. Push the **ENTER** button once more.

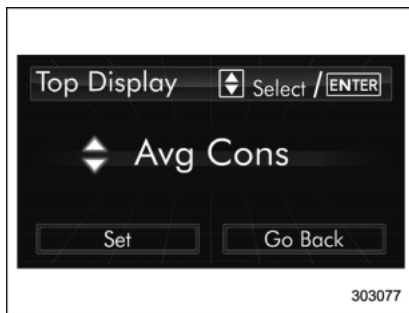

4. Select an item by operating the “▲” or “▼” switch. Then push the **ENTER** button.

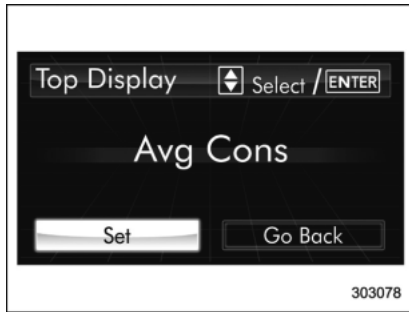

5. Select “Set” by operating the “▼” switch, and confirm the setting by pushing the **ENTER** button.

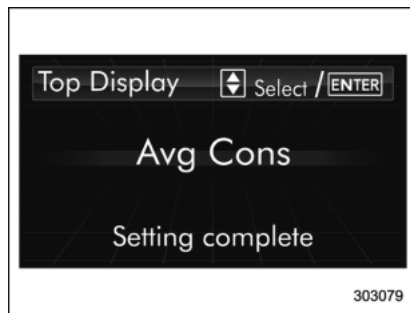

6. The system will notify you that the setting is complete.

▼ Fuel consumption screen setting

1. Perform the preparation steps according to “Preparation for screen settings” 3-69.

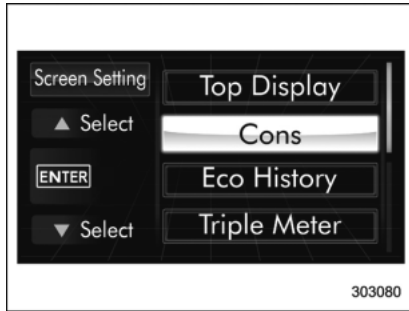

2. Operate the "▲" or "▼" switch to select the "Cons" item. Then push the **ENTER** button.

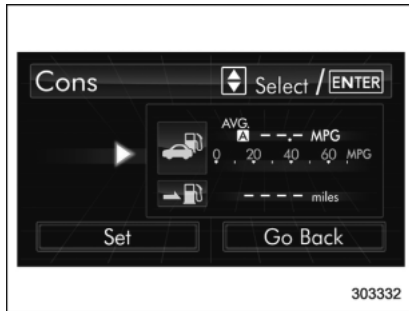

3. Push the **ENTER** button once more.

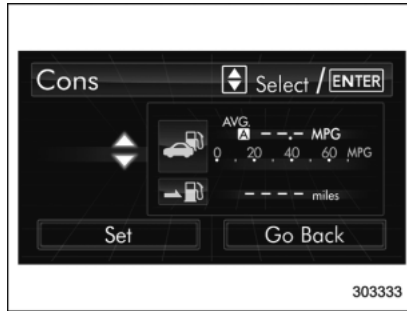

4. Select the displayed configuration by operating the "▲" or "▼" switch. Then push the **ENTER** button.

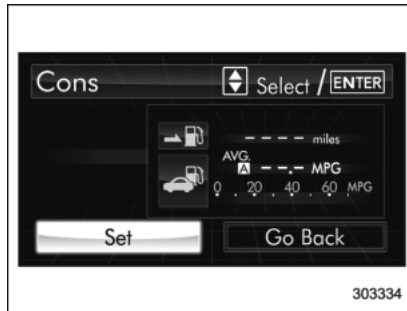

5. Select "Set" by operating the "▼" switch, and confirm the setting by pushing the **ENTER** button.



6. The system will notify you that the setting is complete.

▼ Economy history setting

1. Perform the preparation steps according to "Preparation for screen settings" 3-69.

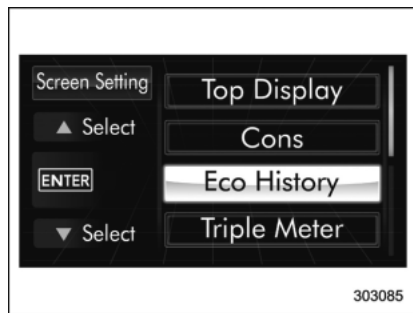

2. Operate the “▲” or “▼” switch to select the “Eco History” item. Then push the **ENTER** button.

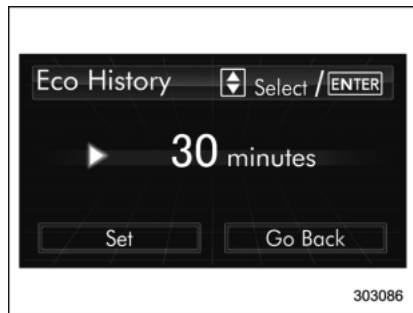

3. Push the **ENTER** button once more.

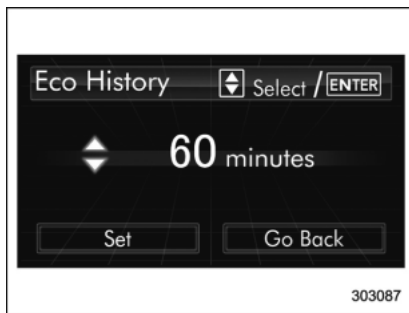

4. Select the time of the logged fuel consumption history by operating the “▲” or “▼” switch, and then push the **ENTER** button.

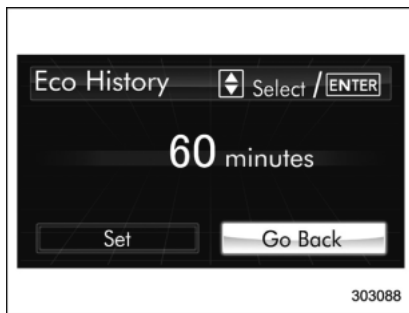

5. Select “Go Back” by operating the “▲” switch.

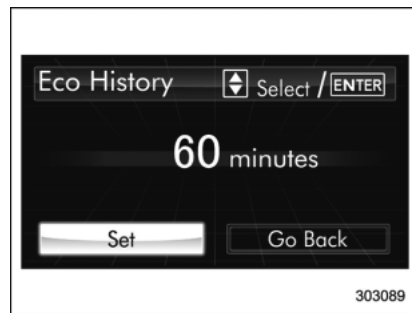

6. Select “Set” by operating the “▲” switch and confirm the setting by pushing the **ENTER** button.

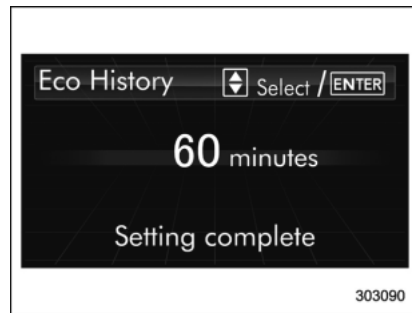

7. The system will notify you that the setting is complete.

▼ Triple meter setting

1. Perform the preparation steps according to "Preparation for screen settings" 3-69.

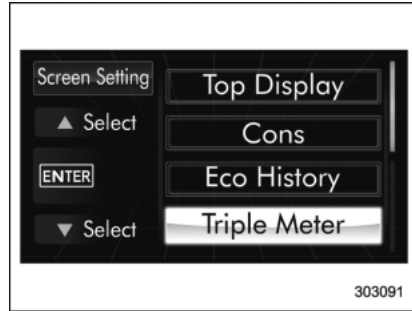

2. Operate the "▲" or "▼" switch to select the "Triple Meter" item. Then push the **ENTER** button.

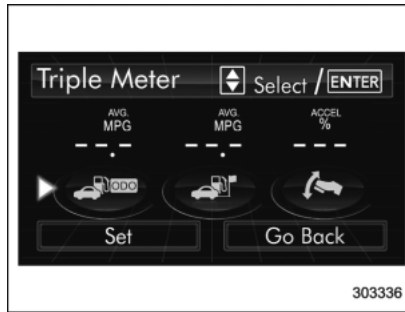

3. Select the setting location (left, center or right) by operating the "▼" or "▲" switch. Then push the **ENTER** button.

NOTE

The same item cannot be selected for the left, center or right location.

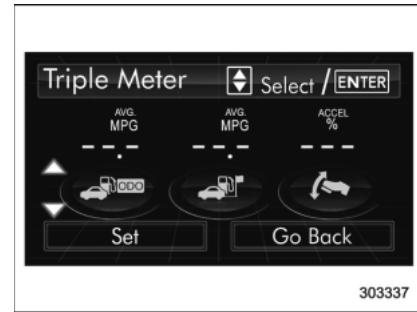

4. Select the preferred item by operating the "▲" or "▼" switch. Then push the **ENTER** button.

If you also want to change the setting for another location, repeat steps 3 and 4.

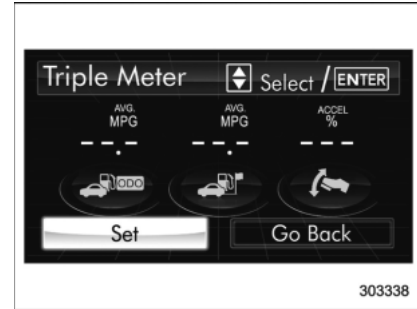

5. Select "Set" by operating the "▼"

3-74 Instruments and controls/Multi function display

switch, and confirm the setting by pushing the **ENTER** button.

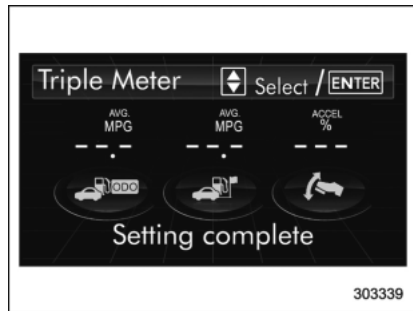

6. The system will notify you that the setting is complete.

▼ Clock/calendar screen setting

1. Perform the preparation steps according to "Preparation for screen settings" 3-69.

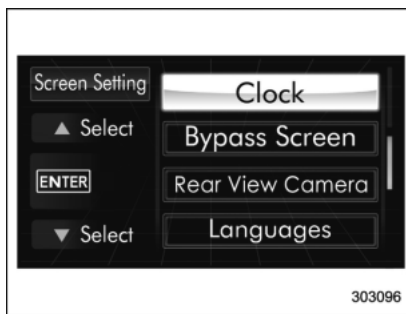

2. Operate the "▲" or "▼" switch to select the "Clock" item. Then push the **ENTER** button.

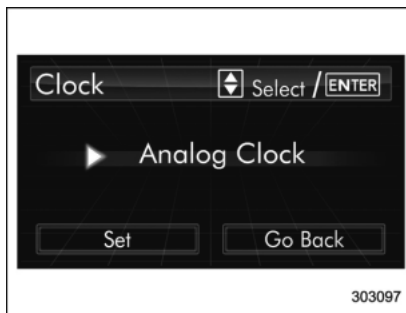

3. Push the **ENTER** button once more.

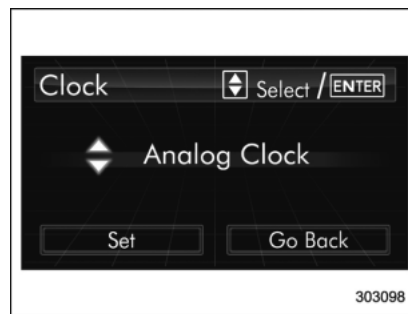

4. Select "Analog Clock", "Digital Clock", "Calendar" or "Off" by operating the "▼" switch. Then push the **ENTER** button.

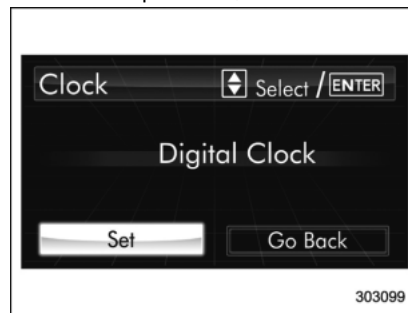

5. Select "Set" by operating the "▼" switch, and confirm the setting by pushing the **ENTER** button.

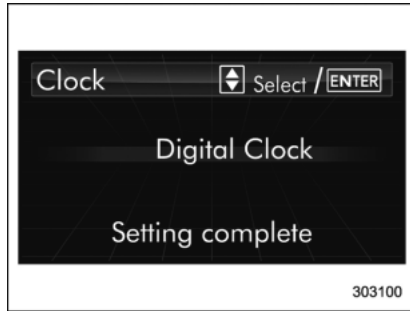

6. The system will notify you that the setting is complete.

▼ Bypass screen setting

1. Perform the preparation steps according to "Preparation for screen settings" 3-69.

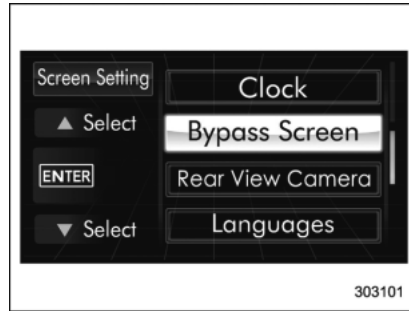

2. Operate the "▲" or "▼" switch to select the "Bypass Screen" item. Then push the **ENTER** button.



3. Select the item to set by operating the "▲" or "▼" switches. Then push the **ENTER** button.

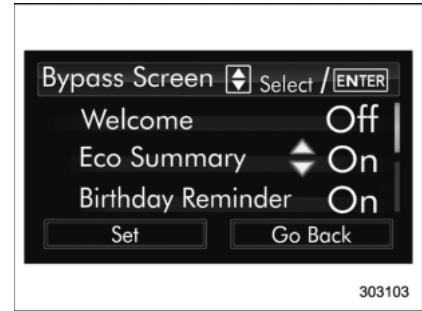

4. Select "On" or "Off" by operating the "▲" or "▼" switch. Then push the **ENTER** button.

If you want to change setting for another item, repeat steps 3 and 4.



5. Select "Set" by operating the "▲" or

“▼” switch, and confirm the setting by pushing the **ENTER** button.

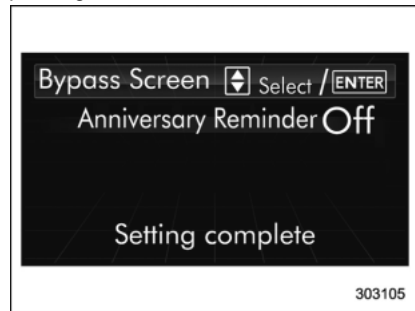

6. The system will notify you that the setting is complete.

▼ Rear view camera image display delayed-off function setting

This function enables the display of the rear view camera image to remain for approximately 9 seconds. However, the image will not be displayed as soon as the select lever is set to the “P” position (CVT models only) or the vehicle speed is above approximately 5 mph (8 km/h). Refer to “How to use the rear view camera” 3-6-13.

1. Perform the preparation steps according to “Preparation for screen settings” 3-6-9.

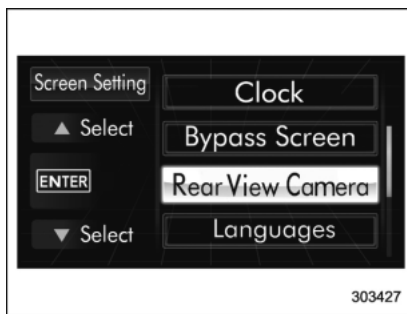

2. Operate the “▲” or “▼” switch to select the “Rear View Camera” item, and then push the **ENTER** button.



3. Push the **ENTER** button.



4. Select an item by operating the “▲” or “▼” switch, and then push the **ENTER** button.



5. Select “Set” by operating the “▼” switch, and confirm the setting by pushing the **ENTER** button.



6. The system will notify you that the setting is complete.

▼ Language setting

1. Perform the preparation steps according to "Preparation for screen settings" 3-69.

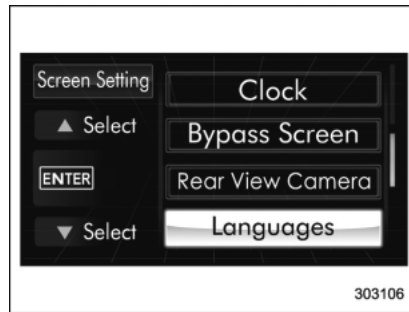

2. Operate the "▲" or "▼" switch to select the "Languages" item. Then push the "ENTER" button.



3. The current language setting will be displayed. Push the "ENTER" button to enter the language selection mode.



4. Select the preferred language by operating the "▲" or "▼" switch. Then push the "ENTER" button.



5. Select "Set" by operating the "▼" switch and confirm the setting by pushing the "ENTER" button.



6. The system will notify you that the setting is complete.

■ Maintenance settings

The items in the maintenance settings can be set. To change the items, operate the “▲” or “▼” switch.

▼ Preparation for maintenance settings

1. Turn the ignition switch to the “ON” position.
2. Push and hold the **ENTER** button to show the selection screen.

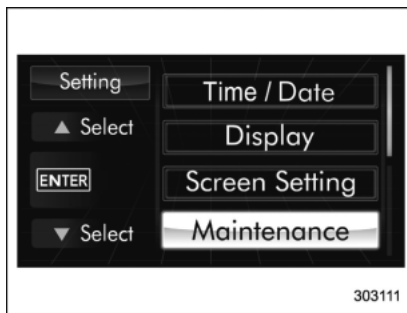

3. After the selection screen is displayed, operate the “▲” or “▼” switch to show the “Maintenance” item. Then, push the **ENTER** button.

▼ Engine oil setting

1. Perform the preparation steps according to “Preparation for maintenance settings” 3-78.

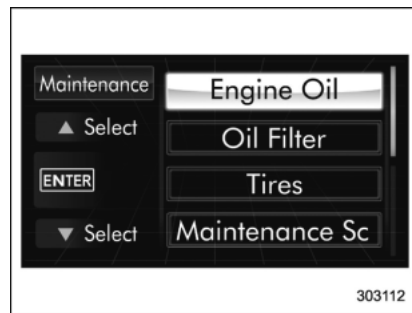

2. Operate the “▲” or “▼” switch to select the “Engine Oil” item. Then push the **ENTER** button.



3. Select the setting location (month, day, year or distance) by operating the “▼” or “▲” switch. Then push the **ENTER** button.



4. Select a number by operating the “▲” or “▼” switch. Then push the **ENTER** button. If you also want to change the setting for another location, repeat steps 3 and 4.

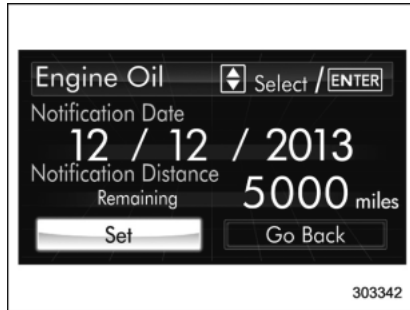

5. Select “Set” by operating the “▲” or “▼” switch and confirm the setting by

pushing the **ENTER** button.

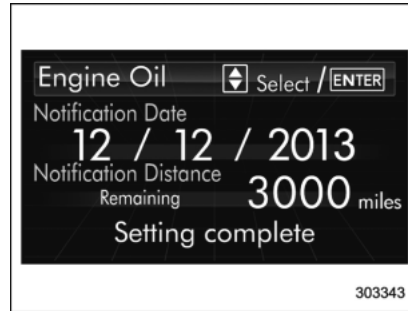

6. The system will notify you that the setting is complete.

NOTE

- The notification will be displayed with information of both date and distance or either date or distance in accordance with the setting
- When “_ _” is selected for either the “Month”, “Day”, “Year” or “Distance” item instead of numbers, the set notification will be deactivated.
- If the notification continues for 15 days or more, the system will display “_ _” on the screen.
- When the distance announcement reaches 0 km, the display will show “0000” for the next 311 miles (500 km).

After exceeding 311 miles (500 km), “_ _ _ _” will be displayed.

▼ Oil filter setting

The setting procedure is the same as “Engine oil setting” ¶3-78, but select the “Oil Filter” item in step 2.

▼ Tires setting

The setting procedure is the same as “Engine oil setting” ¶3-78, but select the “Tires” item in step 2.

▼ Maintenance schedule setting

The setting procedure is the same as “Engine oil setting” ¶3-78, but select the “Maintenance Schedule” item in step 2.

▼ On/Off setting

1. Perform the preparation steps according to “Preparation for maintenance settings” ¶3-78.



2. Operate the “▲” or “▼” switch to select the “On/Off” item. Then push the **ENTER** button.



3. The current setting will be displayed. Push the **ENTER** button to enter the selection mode.

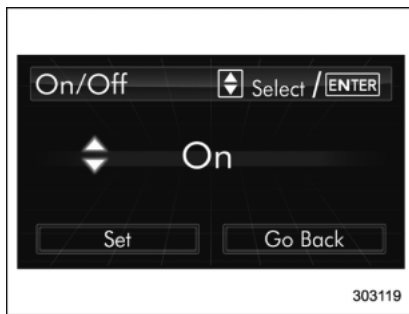

4. Select “On” or “Off” by operating the “▲” or “▼” switch. Then push the **ENTER** button.



5. Select “Set” by operating the “▼” switch, and confirm the setting by pushing the **ENTER** button.



6. The system will notify you that the setting is complete.

▼ Clear setting

1. Perform the preparation steps according to “Preparation for maintenance settings” 3-78.



2. Operate the “▲” or “▼” switch to select the “Clear All Settings” item. Then push the **ENTER** button.

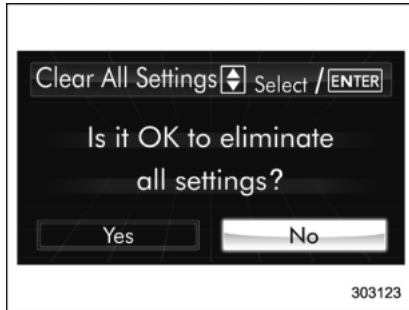

3. The system will prompt a Yes/No dialogue (“No” is selected first). To clear all maintenance settings, select “Yes” by

operating the “▼” switch.

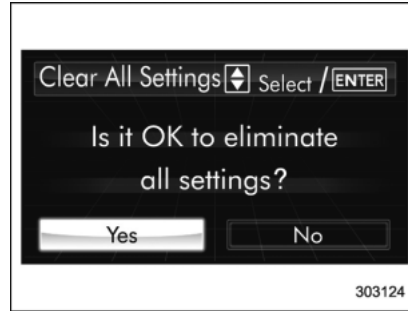

4. Confirm the setting by pushing the **ENTER** button.

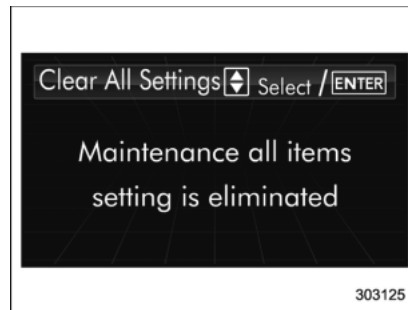

5. The system will notify you that the setting is complete.

■ Driving history registration

The items in the driving history can be registered. To change the items, operate the “▲” or “▼” switch, and then push the **ENTER** button.

1. Turn the ignition switch to the “ON” position.
2. Push and hold the **ENTER** button to show the selection screen.

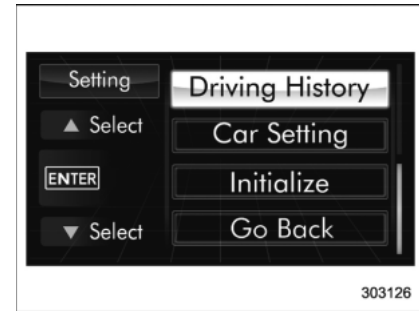

3. After the selection screen is displayed, operate the “▲” or “▼” switch to show the “Driving History” item. Then, push the **ENTER** button.

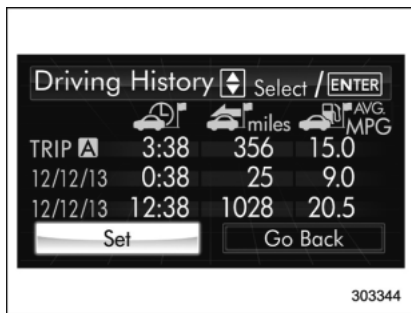

4. Push the **ENTER** button once more to enter the setting mode.



5. The system will notify you of the place to be selected for approximately 2 seconds.

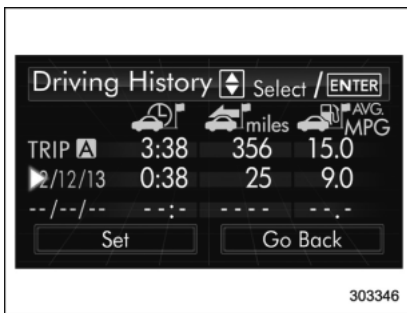

6. Select one of the registration lines by operating the **▲** or **▼** switch. Then push the **ENTER** button.



7. To overwrite the previous registration, push the **ENTER** button. When registration is performed the first time, it is registered

directly without a notification.

8. The system will notify you that the registration is complete.

■ Car settings

The items in the car settings can be set. To change the items, operate the **▲** or **▼** switch, and then push the **ENTER** button.

▼ Preparation for car settings

1. Turn the ignition switch to the "ON" position.
2. Push and hold the **ENTER** button to show the selection screen.

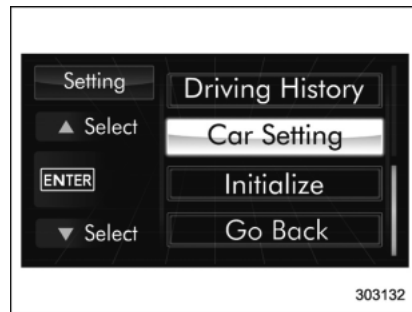

3. After the selection screen is displayed, operate the **▲** or **▼** switch to show the "Car Setting" item. Then, push the **ENTER** button.

▼ Audible signal setting

1. Perform the preparation steps according to "Preparation for car settings" 3-82.



2. Operate the "▲" or "▼" switch to select the "Audible Signal" item. Then push the 'ENTER' button.



3. The current setting will be displayed. Push the 'ENTER' button to enter the selection mode.

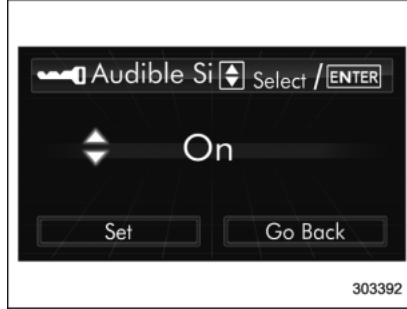

4. Select "On" or "Off" by operating the "▲" or "▼" switch. Then push the 'ENTER' button.



5. Select "Set" by operating the "▼" switch, and confirm the setting by pushing the 'ENTER' button.

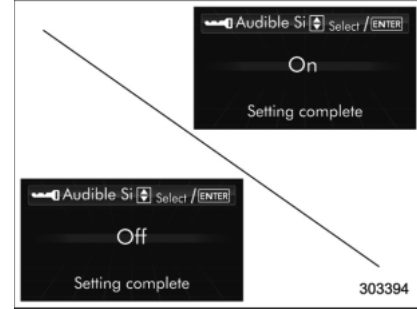

6. The system will notify you that the setting is complete. If the setting is not available, the following notification will be displayed. In this case, perform the setting procedure again.

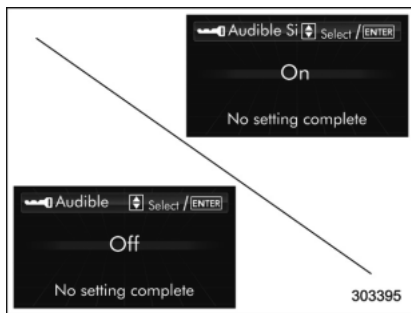

▼ Hazard warning flasher setting

1. Perform the preparation steps according to "Preparation for car settings" 3-82.

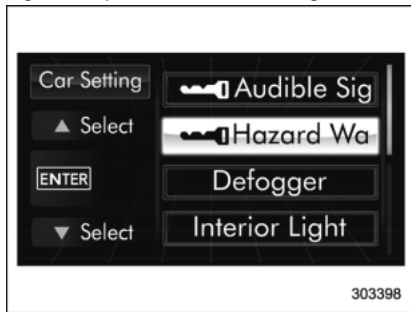

2. Operate the "▲" or "▼" switch to select the "Hazard Warning Flasher" item.

Then push the 'ENTER' button.



3. The current setting will be displayed. Push the 'ENTER' button to enter the selection mode.

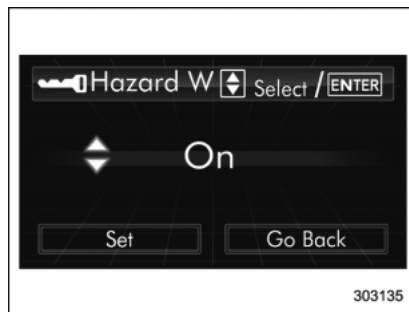

4. Select "On" or "Off" by operating the "▲" or "▼" switch. Then push the 'ENTER' button.

button.



5. Select "Set" by operating the "▼" switch, and confirm the setting by pushing the 'ENTER' button.

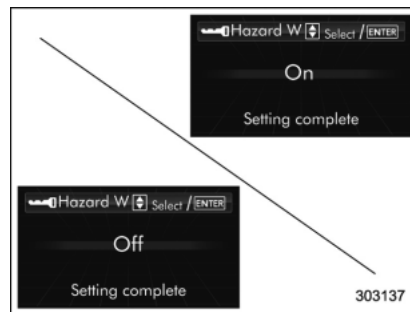

6. The system will notify you that the setting is complete.

If the setting is not available, the following notification will be displayed. In this case, perform the setting procedure again.

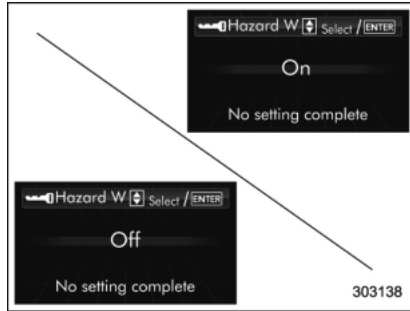

▼ Defogger setting

1. Perform the preparation steps according to “Preparation for car settings” 3-82.

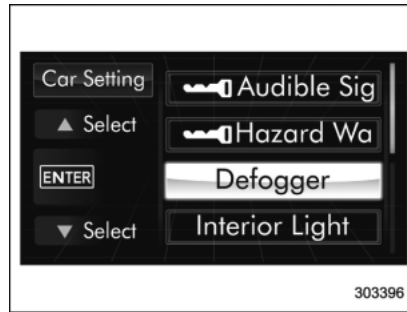

2. Operate the “▲” or “▼” switch to select the “Defogger” item. Then push the **ENTER** button.

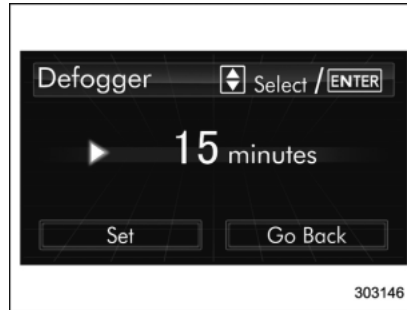

3. The current setting will be displayed. Push the **ENTER** button to enter the selection mode.



4. Select the preferred setting by operating the “▲” or “▼” switch. Then push the **ENTER** button.

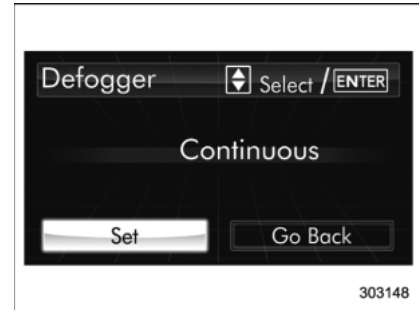

5. Select “Set” by operating the “▼” switch, and confirm the setting by pushing the **ENTER** button.

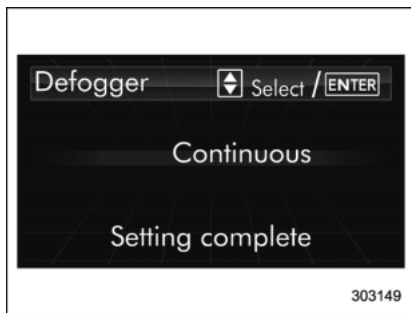

6. The system will notify you that the setting is complete.
If the setting is not available, the following notification will be displayed. In this case, perform the setting procedure again.

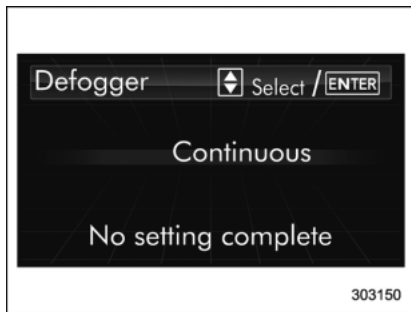

▼ **Interior light off delay timer setting**

1. Perform the preparation steps according to "Preparation for car settings" 3-82.



2. Operate the "▲" or "▼" switch to select the "Interior Light" item. Then push the 'ENTER' button.

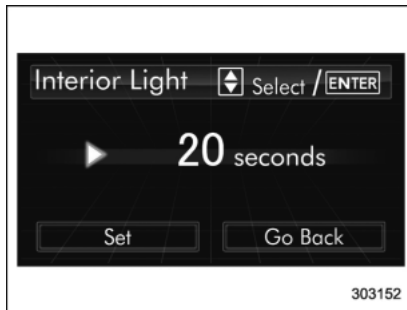

3. The current setting will be displayed. Push the 'ENTER' button to enter the selection mode.

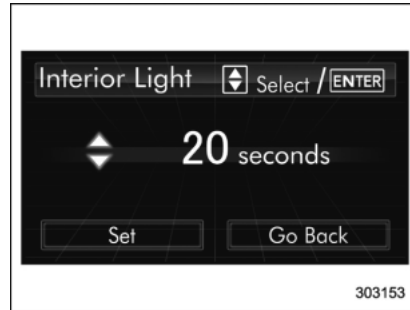

4. Select the preferred setting by operating the "▲" or "▼" switch. Then push the 'ENTER' button.

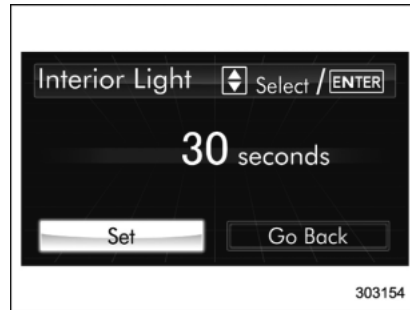

5. Select “Set” by operating the “▼” switch, and confirm the setting by pushing the **ENTER** button.

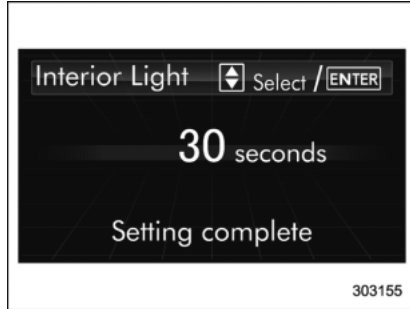

6. The system will notify you that the setting is complete. If the setting is not available, the following notification will be displayed. In this case, perform the setting procedure again.

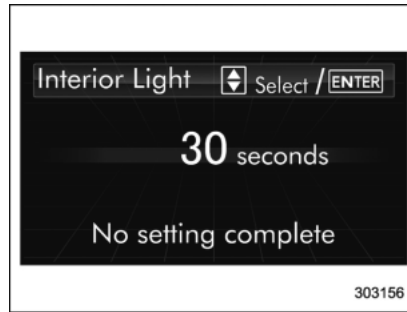

▼ Auto light sensor sensitivity setting

1. Perform the preparation steps according to “Preparation for car settings” 3-82.

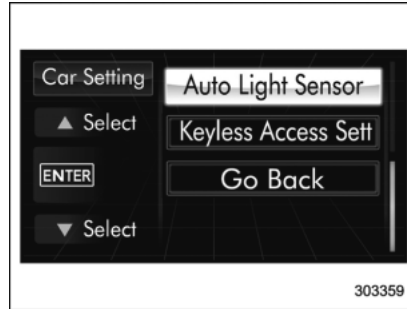

2. Operate the “▲” or “▼” switch to select the “Auto Light Sensor” item. Then

push the **ENTER** button.

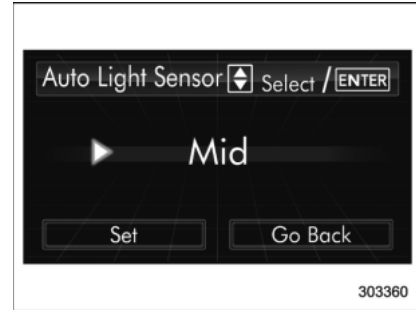

3. The current setting will be displayed. Push the **ENTER** button to enter the selection mode.

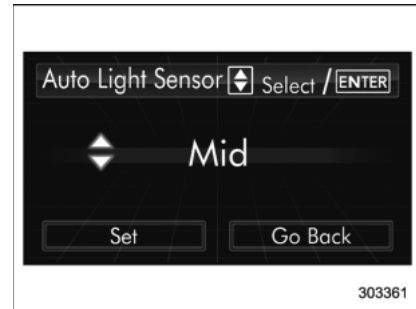

4. Select the preferred setting by operating the “▲” or “▼” switch. Then push the

ENTER button.

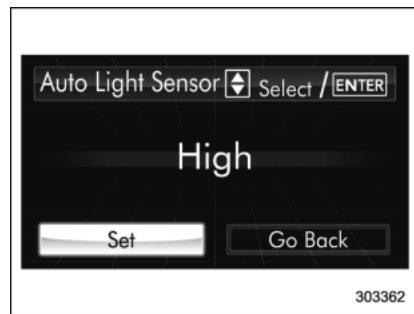

5. Select "Set" by operating the "▼" switch, and confirm the setting by pushing the ENTER button.

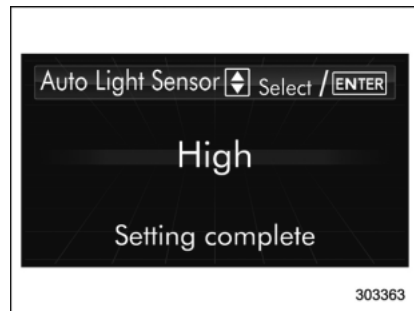

6. The system will notify you that the setting is complete.

If the setting is not available, the following notification will be displayed. In this case, perform the setting procedure again.



▼ **Keyless access setting (models with "keyless access with push-button start system")**

▽ **Preparation for keyless access settings**

1. Perform the preparation steps according to "Preparation for car settings" 3-82.

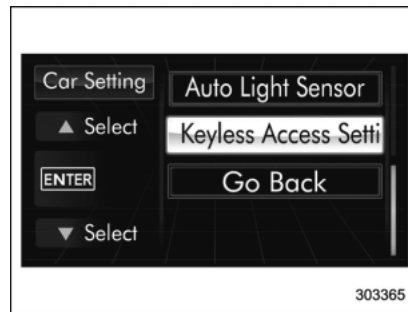

2. Operate the "▲" or "▼" switch to select the "Keyless Access Setting" item. Then push the ENTER button.

▽ **Driver's door unlock setting**

1. Perform the preparation steps according to "Preparation for keyless access settings" 3-88.

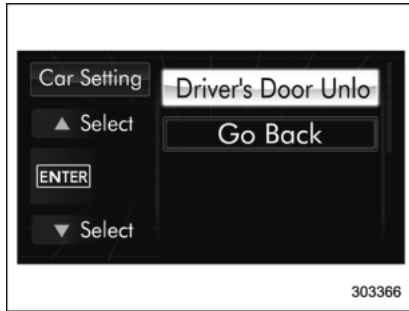

2. Operate the "▲" or "▼" switch to select the "Driver's Door Unlock" item. Then push the **ENTER** button.



3. The current setting will be displayed. Push the **ENTER** button to enter the selection mode.



4. Select the preferred setting by operating the "▲" or "▼" switch. Then push the **ENTER** button.



5. Select "Set" by operating the "▼" switch, and confirm the setting by pushing the **ENTER** button.



6. The system will notify you that the setting is complete.

If the setting is not available, the following notification will be displayed. In this case, perform the setting procedure again.



■ Initialize

Items that have been set to your preference can be initialized. To select an initialization menu, operate the “▲” or “▼” switch as follows.

▼ Preparation for initialization

1. Turn the ignition switch to the “ON” position.
2. Push and hold the **ENTER** button to show the selection screen.



3. After the selection screen is displayed, operate the “▲” or “▼” switch to show the “Initialize” item. Then, push the **ENTER** button.

▼ Reset to factory default settings

1. Perform the preparation steps according to “Preparation for initialization” 3-90.

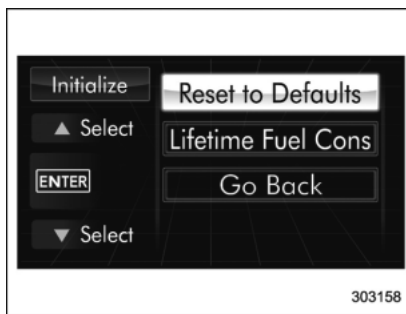

2. Operate the “▲” or “▼” switch to select the “Reset to Defaults” item. Then push the **ENTER** button.

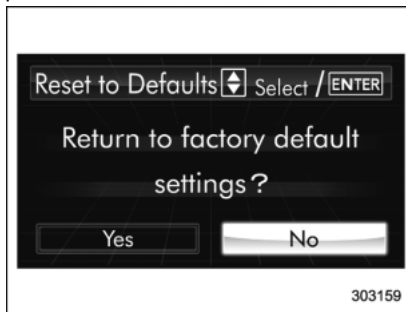

3. The system will prompt a Yes/No dialogue (“No” is selected first). To return to the factory default settings, select “Yes”

by operating the “▼” switch.

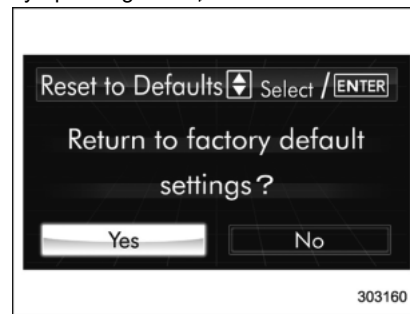

4. Confirm the setting by pushing the **ENTER** button.



5. The system will notify you that the setting is complete.

▼ Lifetime fuel consumption resetting

1. Perform the preparation steps according to "Preparation for initialization" 3-90.

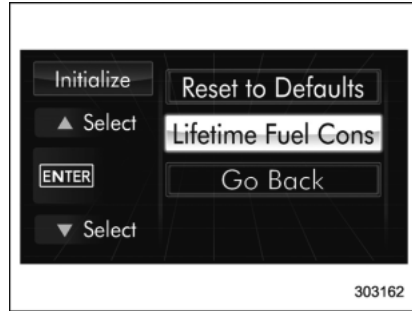

2. Operate the "▲" or "▼" switch to select the "Lifetime Fuel Consumption Resetting" item. Then push the **ENTER** button.

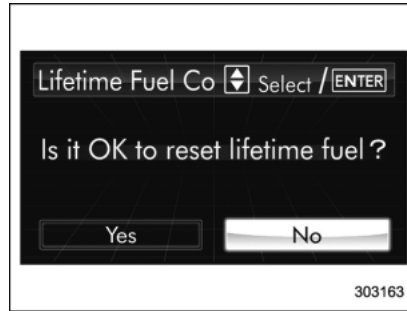

3. The system will prompt a Yes/No dialogue ("No" is selected first). To reset the lifetime fuel consumption, select "Yes" by operating the "▼" switch.

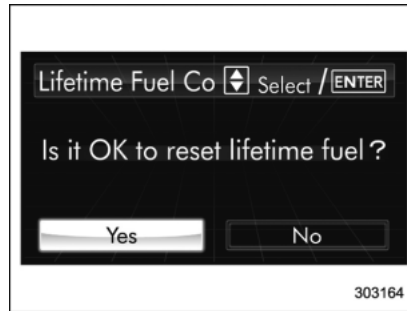

4. Confirm the setting by pushing the **ENTER** button.

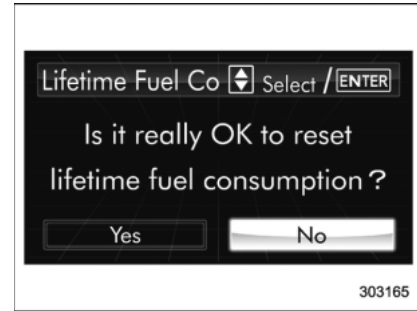

5. Reconfirmation will be displayed. If you are sure you want to proceed, select "Yes" by operating the "▼" switch.

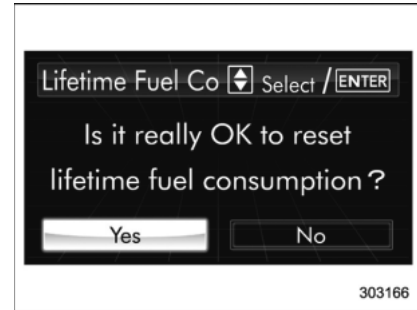

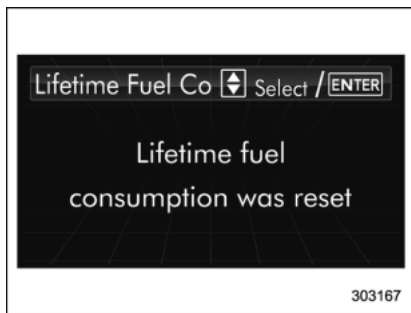

6. Confirm the setting again by pushing the **ENTER** button.



7. The system will notify you that the setting is complete.

■ Audio setting (if equipped)

"MENU" button	
Control dial (type A audio)	
Control dial (type B audio)	

You can set the audio by operating the multi function display.

1. Display the audio screen. For details, refer to "Basic screens" 3-49.
2. Press the "MENU" button on the audio set to display the audio setting screen. The menus are shown in the following table.

First menu	Second menu	Page
BT Audio Setup	Pair Audio	3-93
	Select Audio	3-93
	Set Passkey	3-93
	Delete Audio	3-94
Speed Volume	—	3-94
HD Radio*	—	3-94
Beep	—	3-94
Go Back	—	—

*: If equipped

To select the next menu in the same layer (first or second menu): Press the "MENU" button.

To enter the second menu: Press the control dial while the "BT Audio Setup" menu is selected.

To enter the setting mode of the selected menu: Press the control dial while the menu other than "BT Audio Setup" is selected.

To complete the audio setting: Select the "Go Back" menu and press the control dial. Then the audio screen will be displayed. For details about audio screen, refer to "Audio screen" 3-54.

▼ Bluetooth® audio setting

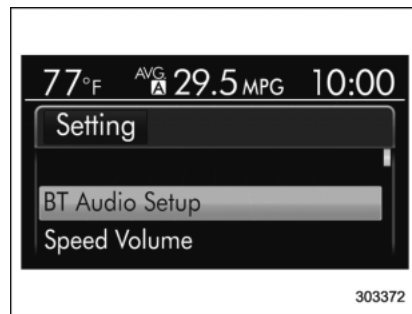

Select the "BT Audio Setup" menu. Then you can set the following items.

▽ **Registering (pairing) audio device**

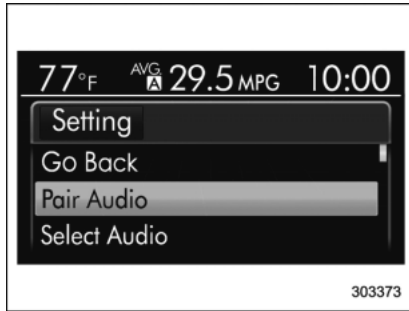

1. Select the "Pair Audio" menu.
2. Perform the procedure described in "Registering (pairing) device" 5-34.

▽ **Selecting audio device**

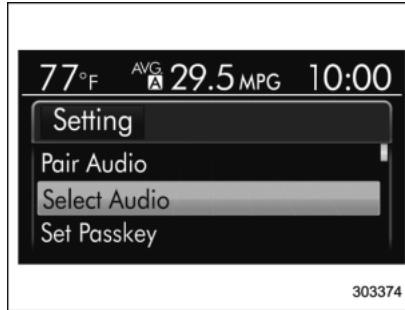

1. Select the "Select Audio" menu.
2. Perform the procedure described in "Selecting device" 5-34.

▽ **Setting passkey**

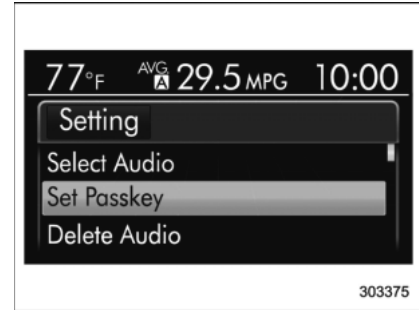

1. Select the "Set Passkey" menu.
2. Perform the procedure described in "Setting passkey" 5-34.

▽ Deleting audio device

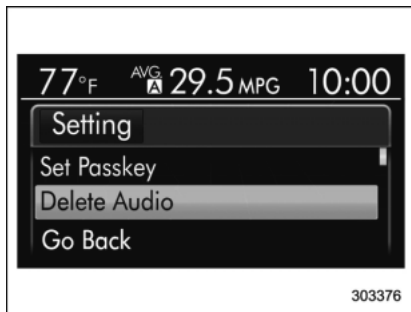

1. Select the "Delete Audio" menu.
2. Perform the procedure described in "Deleting device" 5-34.

▼ Speed volume setting

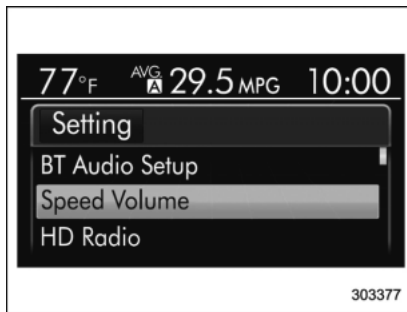

1. Select the "Speed Volume" menu.
2. Operate the control dial to select the preferred setting.

▼ HD radio setting (if equipped)

The setting procedure is the same as "Speed volume setting" 3-94, but select the "HD Radio" item in step 1.



▼ Beep setting

The setting procedure is the same as "Speed volume setting" 3-94, but select the "Beep" item in step 1.

■ Sound setting (if equipped)



Example of the sound setting screen

Control dial (type A audio)	
Control dial (type B audio)	

1. Display the audio screen. For details, refer to "Basic screens" 3-49.
2. Press the control dial on the audio set to display the sound setting screen. You can set the following items by operating the multi function display.

Item	Range of levels
Bass	-8 to +8
Middle	-8 to +8
Treble	-8 to +8
Fader	R9 to F9
Balance	L9 to R9
Virtual Bass*	Off to On
Sound Restorer*	Off to On
Vocal Image Control*	L9 to R9

*: If equipped

To select the next item: Press the control dial.

To set the selected item: Turn the control dial.

For details, refer to "Tone and balance control" ¶5-7.

■ Hands-free system setting

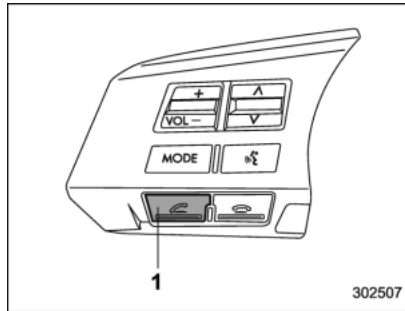

1) OFF hook switch

1. Display the audio screen. For details, refer to "Basic screens" ¶3-49.
2. Press the OFF hook switch to display the "BT-TEL" menu.
3. Select the preferred menu.

The menus are categorized. The following menus come under category 1.

- Phone Book
- Redial
- Call Back
- Setup

If you press the OFF hook switch while a category 1 menu is displayed, you can select the "Top Redial" menu.

▼ Phonebook setting

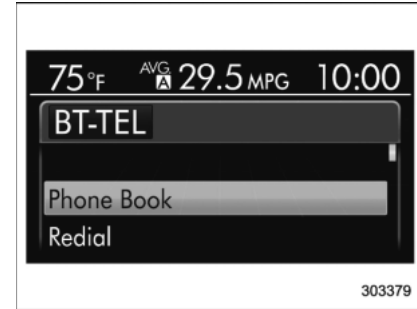

Select the "Phone Book" menu. Then you can add, use, set or delete phonebook data as follows.

▽ Adding phonebook entry

Select the "Add Entry" menu. Then you can select the following menus to add a phone number to the phonebook.

- "By Voice" menu to add by saying a number.
- "By Phone" menu to add by using a cell phone.
- "Manual Input" menu to add by inputting manually.
- "Call History" menu to add from the call history. After selecting the "Call History" menu, select the "Incoming" or "Outgoing" menu.

- “Go Back” menu to go back to the “BT-TEL” menu.

▽ Using list names function

Select the “List Names” menu to show the list of the names (voice tags) registered in the phonebook. For details, refer to “List names function” 5-51.

▽ Changing name

Select the “Change Name” menu to change the name (voice tag) registered in the phonebook.

▽ Setting speed dial

Select the “Set Speed Dial” menu to register a speed dial.

▽ Deleting phonebook entry

Select the “Delete Entry” menu to delete phonebook data.

▽ Deleting speed dial

Select the “Delete Speed Dial” menu to delete a registered speed dial.

▼ Redial setting

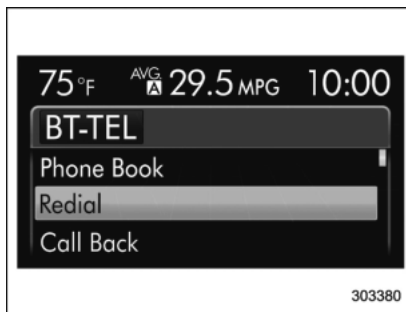

Select the “Redial” menu. Then the number stored in the outgoing call history memory will be displayed.

- Select the “Dial” menu to dial the phone number.
- Select the “Store” menu to add the phone number to the phonebook.
- Select the “Delete” menu to delete the phone number from the outgoing call history.
- Select the “Go Back” menu to go back to the “BT-TEL” menu.

▼ Callback setting

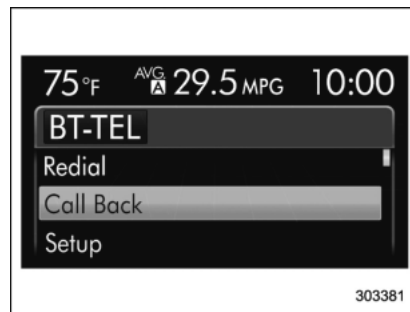

Select the “Call Back” menu. Then the number stored in the incoming call history memory will be displayed.

- Select the “Dial” menu to dial the number.
- Select the “Store” menu to add the phone number to the phonebook.
- Select the “Delete” menu to delete the phone number from the incoming call history.
- Select the “Go Back” menu to go back to the “BT-TEL” menu.

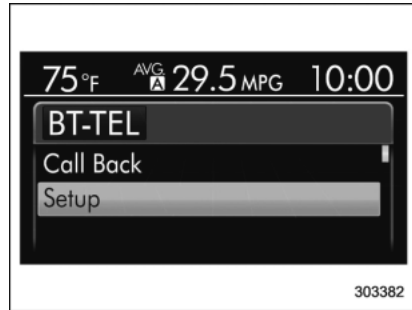
▼ **Setup**

Select the “Setup” menu. Then you can set the following items.

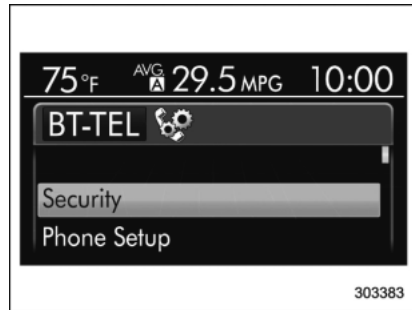
▼ **Security setting**

Select the “Security” menu. Then you can

select the following menus.

- “Set PIN” menu to set a PIN code.
- “Phone Book Lock” menu to lock the phonebook.
- “Phone Book Unlock” menu to unlock the phonebook.
- “Go Back” menu to go back to the “BT-TEL” menu.

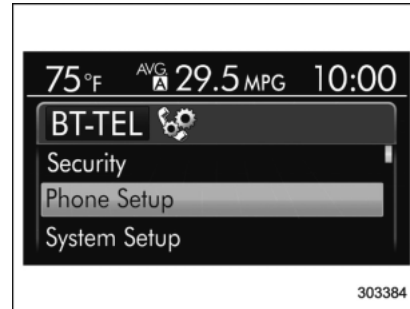
▼ **Phone setting**

Select the “Phone Setup” menu. Then you can select the following menus.

- “Pair Phone” to register a new cell phone.
- “Select Phone” to select a cell phone to be used.
- “Change Name” to change the registered name of the cell phone.

- “List Phones” to show the list of the registered cell phones. For details, refer to “List phones function” 5-53.
- “Set Passkey” to change the pass key.
- “Delete” to delete a registered cell phone.
- “Go Back” menu to go back to the “BT-TEL” menu.

▽ System setting

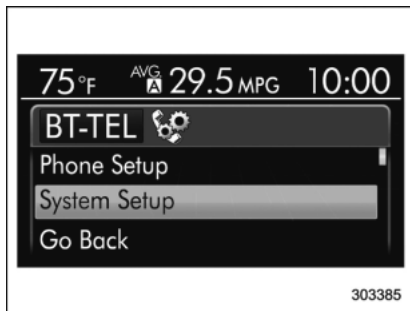

Select the “System Setup” menu. Then you can select the following menus.

- “Guidance Volume” to set the volume of the voice guidance.
- “Initialize” to initialize the settings.
- “Select Language” to select the language (using the Hands-free system).
- “Go Back” menu to go back to the “BT-TEL” menu.

Light control switch

 CAUTION

- Use of any lights for a long period of time while the engine is not running can cause the battery to discharge.
- Before leaving the vehicle, make sure that the lights are turned off. If the vehicle is left unattended for a long time with the lights illuminated, the battery may be discharged.

Models with “keyless access with push-button start system”:

The light control switch operates when the push-button ignition switch is in the “ACC” or “ON” position.

Regardless of the position of the light control switch, the illuminated lights are turned off when the push-button ignition switch is turned off.

Models without “keyless access with push-button start system”:

The light control switch operates when the key is inserted in the ignition switch.

Regardless of the position of the light control switch, the illuminated lights are

turned off when the key is removed from the ignition switch.

NOTE

The light control switch can be operated (except auto on/off headlights), even under the following conditions.

- when the key is not inserted into the ignition switch (models without “keyless access with push-button start system”)
- when the push-button ignition switch is turned off (models with “keyless access with push-button start system”)

If the driver’s door is opened while the headlights are illuminated under such conditions, the chirp sound will inform the driver that the lights are illuminated.

■ Headlights

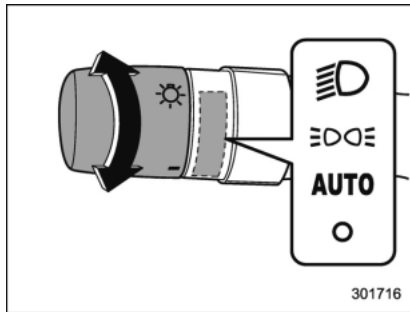

To turn on the headlights, turn the knob on the end of the turn signal lever.

☞ "D" position

Headlights, parking lights, front side marker lights, rear side marker lights, tail lights and license plate lights are on.

☞ "D" position

Parking lights, front side marker lights, rear side marker lights, tail lights and license plate lights are on.

"AUTO" position: auto on/off headlights (if equipped)

When the ignition switch is in the "ON" position, headlights, parking lights, front side marker lights, rear side marker lights, tail lights and license plate lights are automatically on or off depending on the level of the ambient light.

"O" position

The headlights are all off.

NOTE

The sensitivity of the auto on/off headlights can be changed by a SUBARU dealer. Consult your SUBARU dealer for details. Also, for models with a multi function display, the setting can be changed using the display. For details, refer to "Auto light sensor sensitivity setting" 3-87.

▼ Sensor for the auto on/off headlights (if equipped)

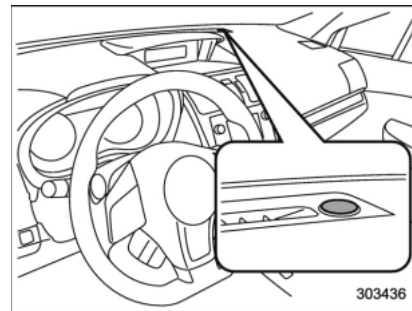

The sensor is on the instrument panel as shown in the illustration.



CAUTION

If any object is placed on or near the sensor, the sensor may not detect the level of the ambient light correctly and the auto on/off headlights may not operate properly.

■ High/low beam change (dimmer)

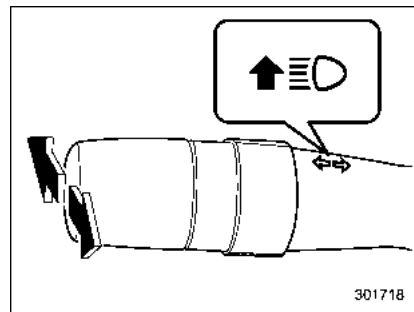

To change from low beam to high beam, push the turn signal lever forward. When the headlights are on high beam, the high beam indicator light “

To switch back to low beam, pull the lever back to the center position.

■ Headlight flasher

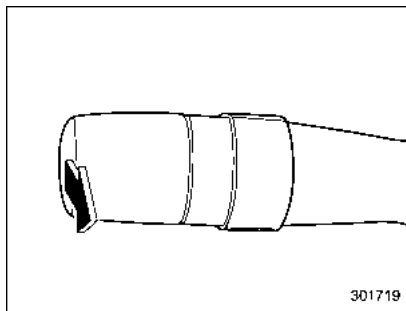

CAUTION

Do not hold the lever in the flashing position for more than just a few seconds.

To flash the headlights, pull the lever toward you and then release it. The high beam will stay on for as long as you hold the lever. The headlight flasher works even though the lighting switch is in the “

When the headlights are on high beam, the high beam indicator light “

■ Daytime running light system

WARNING

The brightness of the illumination of the high beam headlights is reduced by the daytime running light system. The light switch must always be turned to the “

The high beam headlights will automatically illuminate at reduced brightness when the following conditions are fulfilled.

- The engine is running.
- The parking brake is fully released.
- The light control switch is in the “AUTO” (if equipped), “

NOTE

- When the light switch is in the “

level, the high beam headlights that have illuminated at reduced brightness turn off, and the low beam headlights turn on alternatively. At this time, the instrument panel illumination, front side marker lights, tail lights and license plate lights are also illuminated.

Turn signal lever

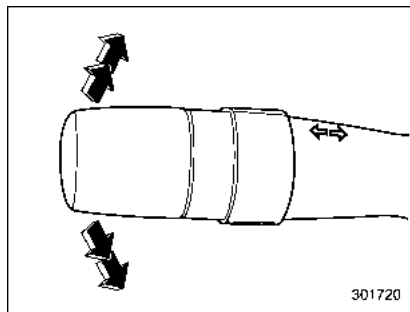

To activate the right turn signal, push the turn signal lever up. To activate the left turn signal, push the turn signal lever down. When the turn is finished, the lever will return automatically. If the lever does not return after cornering, return the lever to the neutral position by hand.

To signal a lane change, push the turn signal lever up or down slightly and hold it during the lane change. The turn signal indicator lights will flash in the direction of the turn or lane change. The lever will return automatically to the neutral position when you release it.

Illumination brightness control

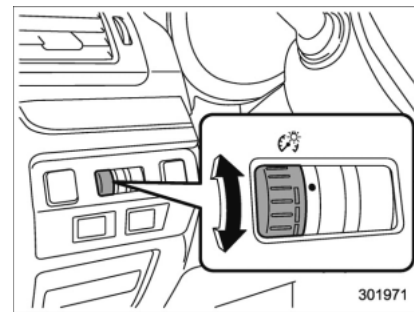

You can adjust the illumination brightness of the combination meter, the climate control panel, etc. by turning the control dial.

- To brighten, turn the control dial upward.
- To darken, turn the control dial downward.

NOTE

- When the control dial is turned fully upward, the illumination brightness becomes the maximum and the automatic dimming function does not work at all.

- The brightness setting is not canceled even when the ignition switch is turned to the “LOCK”/“OFF” position.

Headlight beam leveler (if equipped)

■ Automatic headlight beam leveler (models with LED headlights)

The LED headlights generate more light than conventional halogen headlights.

Therefore a driver of an oncoming vehicle may experience too much glare if your headlight beam height adjustment is high when the vehicle is carrying a heavy load.

The automatic headlight beam leveler adjusts the headlight beam height automatically and optimally according to the load being carried by the vehicle.

Fog light switch (if equipped)

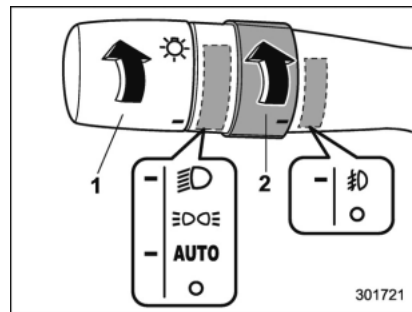

- 1) Headlight switch
- 2) Fog light switch

The front fog lights will turn on when the fog light switch is placed in the “” position while the headlights are in the following condition.

- while the headlight switch is in the “” position
- for models with the auto on/off headlights, while the headlight switch is in the “AUTO” position and the headlights turn on automatically

To turn off the front fog lights, turn the switch back down to the “” position.

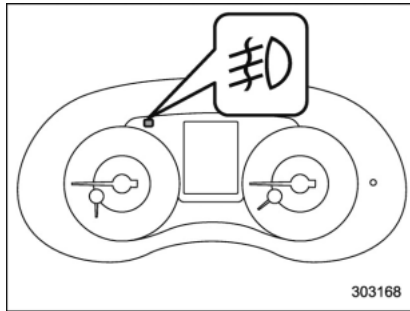

The indicator light on the combination meter will illuminate when the front fog lights are illuminated.

Wiper and washer

⚠ WARNING

In freezing weather, do not use the windshield washer until the windshield is sufficiently warmed by the defroster.

Otherwise the washer fluid can freeze on the windshield, blocking your view.

⚠ CAUTION

- Do not operate the washer continuously for more than 10 seconds, or when the washer fluid tank is empty. This may cause overheating of the washer motor. Check the washer fluid level frequently, such as at fuel stops.
- Do not operate the wipers when the windshield or rear window is dry. This may scratch the glass, damage the wiper blades and cause the wiper motor to burn out. Before operating the wiper on a dry windshield or rear window, always use the windshield washer.

- In freezing weather, be sure that the wiper blades are not frozen to the windshield or rear window before switching on the wipers. Attempting to operate the wiper with the blades frozen to the window glass could cause not only the wiper blades to be damaged but also the wiper motor to burn out. If the wiper blades are frozen to the window glass, be sure to operate the defroster, windshield wiper deicer (if equipped) or rear window defogger before turning on the wiper.
- If the wipers stop during operation because of ice or some other obstruction on the window, the wiper motor could burn out even if the wiper switch is turned off. If this occurs, promptly stop the vehicle in a safe place, turn the ignition switch to the "LOCK"/"OFF" position and clean the window glass to allow proper wiper operation.
- Use clean water if windshield washer fluid is unavailable. In areas where water freezes in winter, use SUBARU Windshield Washer Fluid or the equivalent.

Refer to "Windshield washer fluid" 11-37.

Also, when driving the vehicle when there are freezing temperatures, use non-freezing type wiper blades.

- Do not clean the wiper blades with gasoline or a solvent, such as paint thinner or benzine. This will cause deterioration of the wiper blades.

NOTE

- The windshield wiper motor is protected against overloads by a circuit breaker. If the motor operates continuously under an unusually heavy load, the circuit breaker may trip to stop the motor temporarily. If this happens, park your vehicle in a safe place, turn off the wiper switch, and wait for approximately 10 minutes. The circuit breaker will reset itself, and the wipers will again operate normally.
- Clean your wiper blades and window glass periodically with a washer solution to prevent streaking, and to remove accumulations of road salt or road film. Operate the windshield washer for at least 1 second so that washer solution will be sprinkled all

over the windshield or rear window.

- Grease, wax, insects or other material on the windshield or the wiper blade results in jerky wiper operation and streaking on the glass. If you cannot remove those streaks after operating the washer or if the wiper operation is jerky, clean the outer surface of the windshield or rear window and the wiper blades using a sponge or soft cloth with a neutral detergent or mild-abrasive cleaner. After cleaning, rinse the window glass and wiper blades with clean water. The glass is clean if no beads form on the glass when you rinse with water.

- If you cannot eliminate the streaking even after following this procedure, replace the wiper blades with new ones. For replacement instructions, refer to "Replacement of wiper blades" 11-38.

Windshield wiper and washer switches

The wiper operates only when the ignition switch is in the "ON" position.

Windshield wipers

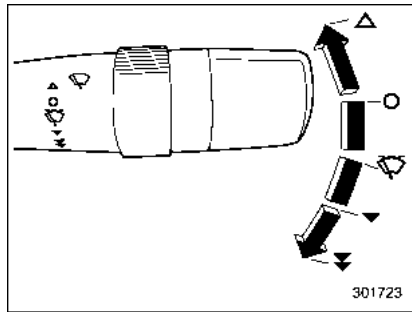

- △ : Mist (for a single wipe)
- : Off
- ⦿ : Intermittent
- ▼ : Low speed
- ▼ : High speed

To turn the wipers on, push the wiper control lever down.

To turn the wipers off, return the lever to the "O" position.

For a single wipe of the wipers, push the lever up. The wipers operate until you release the lever.

▼ Wiper intermittent time control

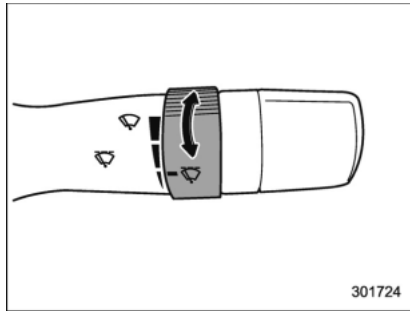

When the wiper switch is in the "☔" position, turn the dial to adjust the operating interval of the wiper. The operating interval can be adjusted in several steps from the shortest interval to the longest.

▼ Windshield washer

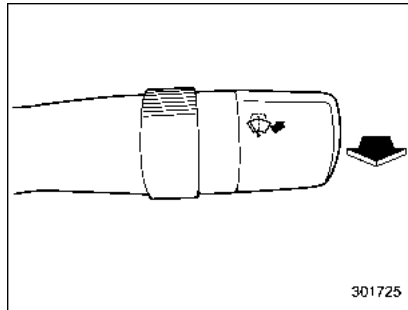

To wash the windshield, pull the wiper control lever toward you. The washer fluid sprays until you release the lever. The wipers operate while you pull the lever.

NOTE

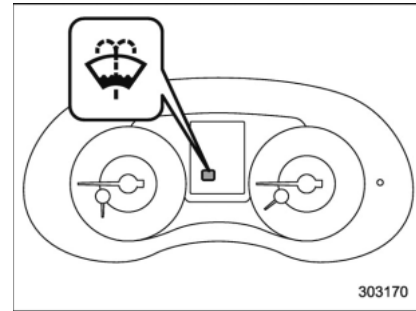

The windshield washer fluid warning indicator appears when the washer fluid level in the tank has dropped to the lower limit. If the warning indicator appears, refill the tank with fluid. For the refilling procedure, refer to "Windshield washer fluid" 11-37.

Mirrors

Always check that the inside and outside mirrors are properly adjusted before you start driving.

■ Inside mirror

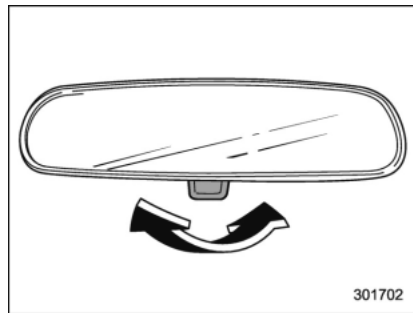

The inside mirror has a day and night feature. Pull the tab at the bottom of the mirror toward you for the night position. Push it away for the day position. The night position reduces glare from headlights.

■ Auto-dimming mirror/compass (if equipped)

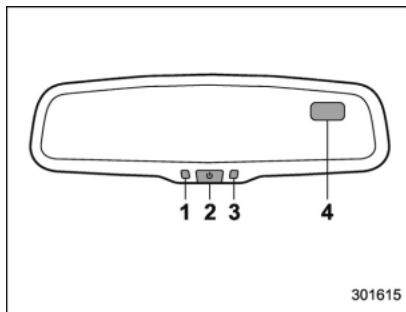

- 1) LED
- 2) Switch
- 3) Sensor
- 4) Compass display

The auto-dimming mirror has an anti-glare feature which automatically reduces glare coming from headlights of vehicles behind you. It also contains a built-in compass.

- By pressing and holding the switch for 3 seconds, the automatic dimming function is toggled on or off. When the automatic dimming function is on, the LED indicator will illuminate.

Even with the mirror in anti-glare mode, the mirror surface turns bright if the transmission is shifted into reverse. This

is to ensure good rearward visibility during reversing.

- By pressing and releasing the switch for less than 3 seconds, the compass display is toggled on or off. When the compass is on, an illuminated compass reading will appear in the upper right corner of the mirror.

When cleaning the mirror, use a paper towel or similar material dampened with glass cleaner. Do not spray glass cleaner directly on the mirror as that may cause the liquid cleaner to enter the mirror housing and damage the mirror.

▼ Photosensors

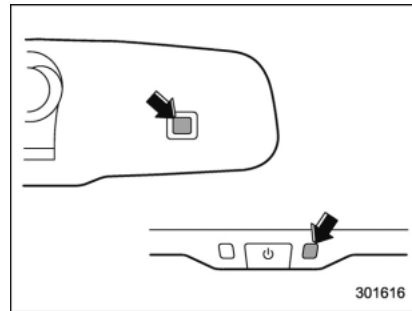

The mirror has a photosensor attached on the front and back sides. During nighttime driving, these sensors detect distracting

glare from vehicle headlights behind you and automatically dim the mirror to eliminate glare and preserve your vision. For this reason, use care not to cover the sensors with stickers, or other similar items. Periodically wipe the sensors clean using a piece of dry soft cotton cloth or an applicator.

▼ Compass zone adjustment

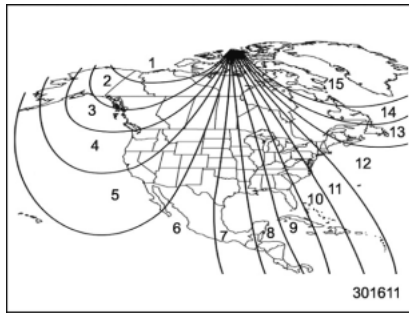

Compass calibration zones

1. Refer to the "Compass calibration zones" map shown above to verify that the compass zone setting is correct for your geographical location.
2. Press and hold the switch for 6 seconds until the zone selection comes up (a number will be displayed in the mirror compass window).

3. Press the switch repeatedly until the correct zone setting for your location is displayed.
4. Releasing the button for 10 seconds will exit the zone setting mode.

▼ Compass calibration

1. If a "C" is displayed in the compass window, the compass needs to be calibrated.
2. Drive the vehicle in a circle at 5 mph (8 km/h) or less until the display reads a direction.
3. You can also calibrate the compass by driving your vehicle on your everyday routine. The compass will be calibrated once it has tracked a complete circle.
4. To recalibrate your compass, push and hold the switch for 9 seconds until a "C" appears in the compass window.
5. Calibrate the compass according to step 2 or step 3.

■ Auto-dimming mirror/compass with HomeLink® (if equipped)

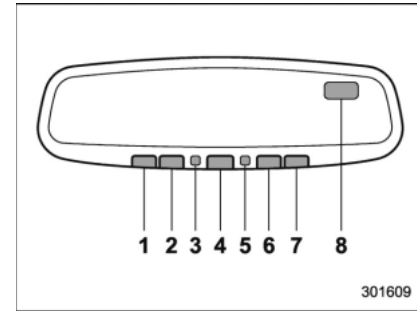

- 1) HomeLink® button 1
- 2) HomeLink® button 2
- 3) LED
- 4) HomeLink® button 3
- 5) Sensor
- 6) Automatic dimming on/off button
- 7) Compass display button
- 8) Compass display

The auto-dimming mirror has an anti-glare feature which automatically reduces glare coming from headlights of vehicles behind you. It also contains a built-in compass and HomeLink® wireless control system.

- By pressing the automatic dimming on/off button, the automatic dimming function is toggled on or off. When the automatic

dimming function is on, the LED indicator will illuminate.

Even with the mirror in the automatic dimming mode, the mirror surface turns bright if the transmission is shifted into reverse. This is to ensure good rearward visibility during reversing.

- By pressing the compass display button, the compass display is toggled on or off. When the compass is on, an illuminated compass reading will appear in the upper right corner of the mirror.

When cleaning the mirror, use a paper towel or similar material dampened with glass cleaner. Do not spray glass cleaner directly on the mirror as that may cause the liquid cleaner to enter the mirror housing and damage the mirror.

▼ Photosensors

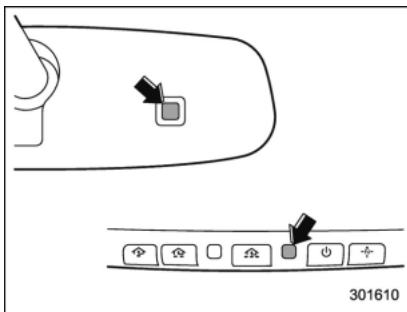

The mirror has a photosensor attached on both the front and back sides. During nighttime driving, these sensors detect distracting glare from vehicle headlights behind you and automatically dim the mirror to eliminate glare and preserve your vision. For this reason, use care not to cover the sensors with stickers, or other similar items. Periodically wipe the sensors clean using a piece of dry soft cotton cloth or an applicator.

▼ Compass zone adjustment

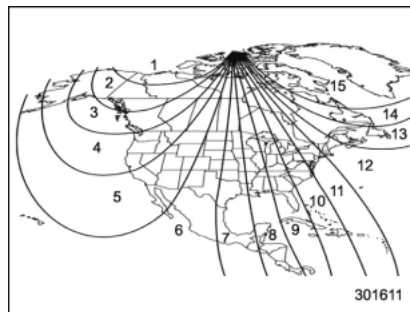

Compass calibration zones

1. Refer to the “Compass calibration zones” map shown above to verify that the compass zone setting is correct for your geographical location.
2. Press and hold the compass display button for 3 seconds until the zone selection comes up (a number will be displayed in the mirror compass window).
3. Press the compass display button repeatedly until the correct zone setting for your location is displayed.
4. Releasing the button for 5 seconds will exit the zone setting mode.

▼ Compass calibration

1. If a "C" is displayed in the compass window, the compass needs to be calibrated.
2. Drive the vehicle in a circle at 5 mph (8 km/h) or less until the display reads a direction.
3. You can also calibrate the compass by driving your vehicle on your everyday routine. The compass will be calibrated once it has tracked a complete circle.
4. To recalibrate your compass, push and hold the compass display button for 9 seconds until a "C" appears in the compass window.
5. Calibrate the compass according to step 2 or step 3.

▼ HomeLink® Wireless Control System

The HomeLink® Wireless Control System can be used to activate remote control devices such as gate operators, garage door openers, door locks, home lighting and security systems.

There are three HomeLink® buttons on the mirror, each of which can be programmed for operation of one desired device. For details on the device types which can be operated by this system, consult the HomeLink® website at:

www.homelink.com or call 1-800-355-3515.

Note the following information about this system.

If your vehicle is equipped with the HomeLink® Wireless Control System, it complies with Part 15 of the Federal Communications Commission Rules in the U.S. and the RSS-210 of Industry Canada in Canada. Its operation is subject to the following two conditions:

(1) this device may not cause harmful interference, and (2) this device must accept any interference received, including interference that may cause undesired operation.

Changes and modifications to this system by anyone other than an authorized service facility could void authorization to use this equipment.

HomeLink® and the HomeLink® house are registered trademarks of Johnson Controls, Inc.

 WARNING

- **When programming the HomeLink® Wireless Control System, you may be operating a garage door opener or other device. Make sure that people**

and objects are out of the way of the garage door or other device to prevent potential harm or damage.

- **Do not use the HomeLink® Wireless Control System with a garage door opener that lacks the safety stop and reverse feature as required by applicable safety standards. A garage door opener which cannot detect an object, signaling the door to stop and reverse, does not meet these safety standards. Using a garage door opener without these features increases risk of serious injury or death. For more information, consult the HomeLink® website at www.homelink.com or call 1-800-355-3515.**

 CAUTION

When programming the HomeLink® Wireless Control System to operate a garage door opener or an entrance gate, unplug the device's motor from the outlet during programming to prevent motor burnout.

NOTE

- After programming your HomeLink® Wireless Control System for the desired devices, retain the hand-held transmitters for further programming or device testing in the event of a problem.
- It is recommended that you insert a new battery in the hand-held transmitter of a device to ensure correct programming.

▽ **Garage door opener programming in the U.S.A.**

NOTE

When programming the HomeLink® Wireless Control System for a garage door opener, it is suggested that you park the vehicle outside the garage.

1. Unplug the motor of the garage door opener from the outlet.

NOTE

If any of the HomeLink® buttons are already programmed for other devices, skip step 2 because it clears the memory of all three buttons.

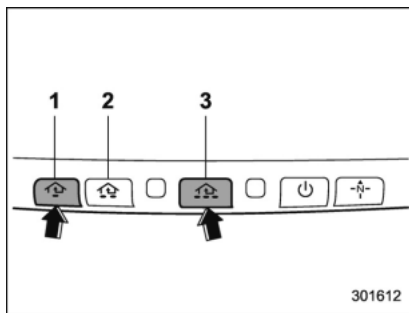

- 1) HomeLink® button 1
- 2) HomeLink® button 2
- 3) HomeLink® button 3

2. Press and hold the two outer HomeLink® buttons (button 1 and button 3) until the indicator light begins to flash (after approximately 20 seconds). Then release both buttons.

3. Hold the end of the garage door opener's hand-held transmitter between 1 and 3 inches (25 and 76 mm) away from the HomeLink® button you wish to program.

4. Simultaneously press and hold both the hand-held transmitter button and the desired HomeLink® button. DO NOT release the buttons until step 5 has been completed.

NOTE

Some gate operators and garage door openers may require you to replace this programming step 4 with procedures in "Programming for entrance gates and garage door openers in Canada" 3-111.

5. Hold down both buttons until the HomeLink® indicator light flashes, first slowly then rapidly. When the indicator light flashes rapidly, both buttons may be released. (The rapidly flashing light indicates successful programming of the new frequency signal.)

6. Press and hold the programmed button and check the HomeLink® indicator light. If the indicator light stays on continuously, your garage door should activate and the programming is completed.

If the indicator light flashes rapidly for 2 seconds and then stays on continuously, your garage door opener may be protected by a rolling code feature. In this case you need to perform the additional steps that are described in "Programming rolling-code-protected garage door openers in the U.S.A." 3-111.

▽ **Programming rolling-code-protected garage door openers in the U.S.A.**

If your garage door opener has a rolling code feature, program the HomeLink® Wireless Control System for it by following steps 1 through 5 in “Garage door opener programming in the U.S.A.” 3-110. Then continue with the following steps.

NOTE

The assistance of a second person may make the programming quicker and easier.

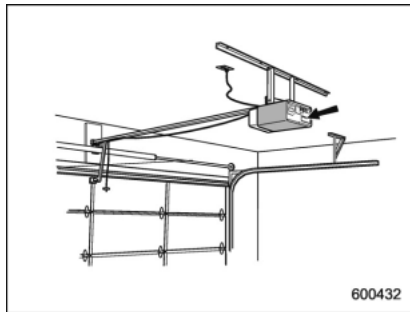

1. Locate the training button on the garage door opener motor head unit. The exact location and color of the button may vary by brand of garage door opener. If it is difficult to locate the training button,

refer to your garage door opener's instruction manual.

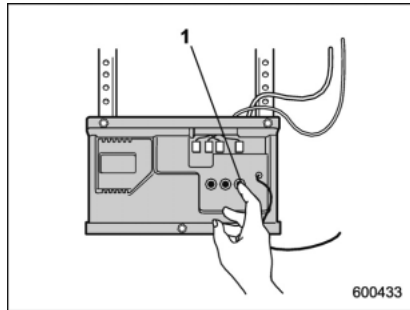

1) Training button

2. Press the training button on the garage door opener motor head unit (which activates the “training light” on the unit). Proceed to step 3 within 30 seconds.
3. Inside the vehicle, firmly press, hold for 2 seconds and release the HomeLink® button that was programmed in the previous section. Press and release the button a second time to complete the programming procedure.

NOTE

Some garage door openers may require you to do the above press-hold-release sequence a third time to complete the programming.

4. The garage door opener should now recognize the HomeLink® Wireless Control System and your garage door opener should activate when the HomeLink® button is pressed.

▽ **Programming for entrance gates and garage door openers in Canada**

1. Unplug the motor of the entrance gate or garage door opener from the outlet.

NOTE

If any of the HomeLink® buttons are already programmed for other devices, skip step 2 because it clears the memory of all three buttons.

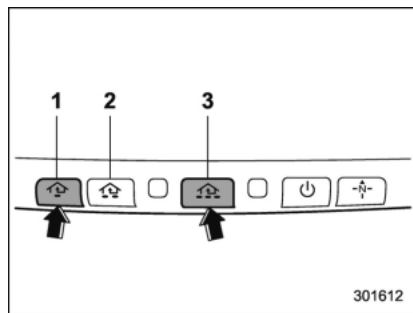

- 1) HomeLink® button 1
- 2) HomeLink® button 2
- 3) HomeLink® button 3

2. Press and hold the two outer HomeLink® buttons (button 1 and button 3) until the HomeLink® indicator light begins to flash (after approximately 20 seconds). Then release both buttons.

3. Hold the end of the entrance gate's/ garage door opener's hand-held transmitter between 1 and 3 inches (25 and 76 mm) away from the HomeLink® button you wish to program.

4. Press and hold the desired HomeLink® button.

5. Press and release ("cycle") the hand-held transmitter button every 2 seconds until step 6 is complete.

6. When the indicator light flashes slowly and then rapidly after several seconds, release both buttons.

7. Plug the motor of the entrance gate/ garage door opener to the outlet.

8. Test your entrance gate/garage door opener by pressing the programmed HomeLink® button.

▽ Operating the HomeLink® Wireless Control System

Once programmed, the HomeLink® Wireless Control System can be used to remote-control the devices to which its buttons are programmed. To activate a device, simply press the appropriate button. The indicator light illuminates, indicating that the signal is being transmitted.

▽ Programming other devices

To program other devices such as door locks, home lighting and security systems, contact HomeLink® at www.homelink.com or call 1-800-355-3515.

▽ Reprogramming a single HomeLink® button

1. Press and hold the HomeLink® button you wish to reprogram. DO NOT release the button until step 4 has been completed.

2. When the HomeLink® indicator light

begins to flash slowly (after approximately 20 seconds), position the hand-held transmitter of the device between 1 to 3 inches (25 to 76 mm) away from the HomeLink® button you wish to program.

3. Press and hold the hand-held transmitter button. The HomeLink® indicator light will flash, first slowly and then rapidly.

4. When the indicator light begins to flash rapidly, release both buttons.

The programming for the previous device is now erased and the new device can be operated by pressing the HomeLink® button.

▽ Erasing HomeLink® button memory

NOTE

- Performing this procedure erases the memory of all the preprogrammed buttons simultaneously. The memory of individual buttons cannot be erased.
- It is recommended that upon the sale of the vehicle, the memory of all programmed HomeLink® buttons be erased for security purposes.

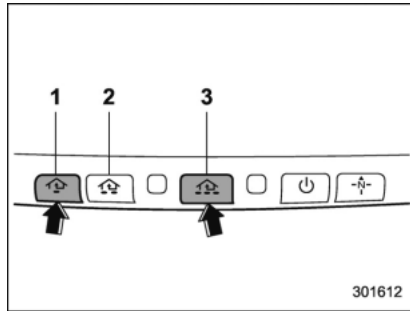

- 1) HomeLink® button 1
- 2) HomeLink® button 2
- 3) HomeLink® button 3

1. Press and hold the two outer buttons (button 1 and button 3) until the indicator light begins to flash (after approximately 20 seconds).
2. Release both buttons.

▽ In case a problem occurs

If you cannot activate a device using the corresponding HomeLink® button after programming, contact HomeLink® at www.homelink.com or call 1-800-355-3515 for assistance.

■ Outside mirrors

▼ Convex mirror (passenger side)

▲ WARNING

Objects look smaller in a convex mirror and farther away than when viewed in a flat mirror. Do not use the convex mirror to judge the distance of vehicles behind you when changing lanes. Use the inside mirror (or glance backwards) to determine the actual size and distance of objects that you view in convex mirror.

▼ Remote control mirror switch

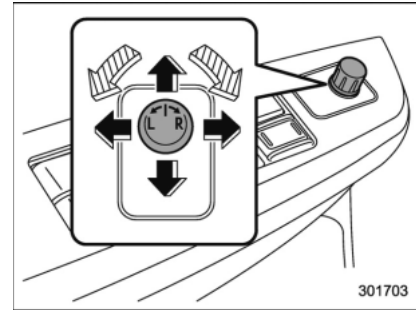

🔧: Select side to adjust

➡: Direction control

The remote control mirrors operate only when the ignition switch is in the "ON" or "ACC" position.

1. Turn the control switch to the side that you want to adjust. "L" is for the left mirror, "R" is for the right mirror.
2. Move the control switch in the direction you want to move the mirror.
3. Return the control switch to the neutral position to prevent unintentional operation.

The mirrors can also be adjusted manually.

Defogger and deicer

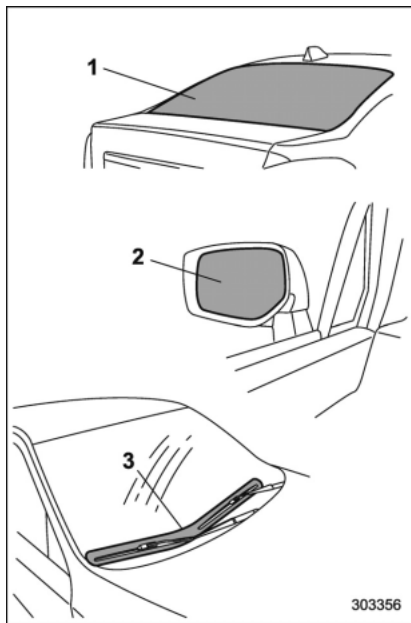

- 1) Rear window defogger
- 2) Outside mirror defogger (if equipped)
- 3) Windshield wiper deicer (if equipped)

The defogger and deicer system is acti-

vated only when the ignition switch is in the "ON" position.

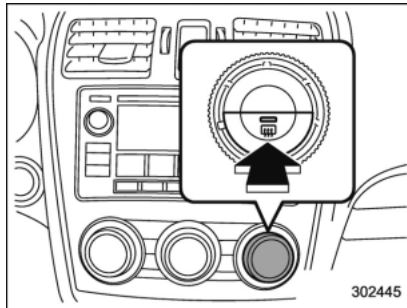

To activate the defogger and deicer system, press the control switch that is located on the climate control panel. The rear window defogger, outside mirror defogger and windshield wiper deicer are activated simultaneously. The indicator light on the control switch illuminates while the defogger and deicer system is activated.

To turn them off, press the control switch again. They also turn off when the ignition switch is turned to the "ACC" or "LOCK"/"OFF" position.

The defogger and deicer system will automatically shut off after approximately 15 minutes. If the rear window and the

outside mirrors have been cleared and the windshield wiper blades have been deiced completely before that time, press the control switch to turn them off. If defrosting, defogging or deicing is not complete, you have to press the control switch to turn them on again.

It is possible for the defogger and deicer system to be set to continuous operation mode by a SUBARU dealer. Consult your SUBARU dealer for details. Also, for models with a multi function display, the setting can be changed using the display. For details, refer to "Multi function display" 3-45.

If the battery voltage drops below the permissible level, continuous operation of the defogger and deicer system is canceled and the system stops operating.

CAUTION

- To prevent the battery from being discharged, do not operate the defogger and deicer system continuously for any longer than necessary.
- Do not use sharp instruments or window cleaner containing abrasives to clean the inner surface of the rear window. They may

damage the conductors printed on the window.

NOTE

- Turn on the defogger and deicer system if the wipers are frozen to the windshield.
- If the windshield is covered with snow, remove the snow so that the windshield wiper deicer works effectively.
- While the defogger and deicer system is in the continuous operation mode, if the vehicle speed remains at 9 mph (15 km/h) or less for 15 minutes, the windshield wiper deicer automatically stops operating, though the rear window defogger and outside mirror defogger maintain continuous operation in this condition.

Tilt/telescopic steering wheel

WARNING

- Do not adjust the steering wheel tilt/telescopic position while driving. This may cause loss of vehicle control and result in personal injury.
- If the lever cannot be raised to the fixed position, adjust the steering wheel again. It is dangerous to drive without locking the steering wheel. This may cause loss of vehicle control and result in personal injury.

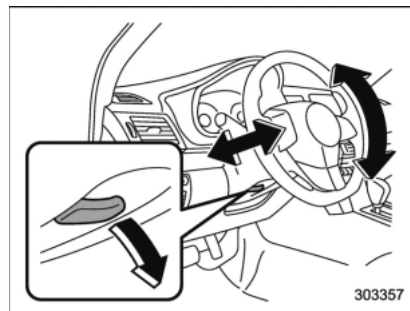

- 1) Tilt adjustment
- 2) Telescopic adjustment

1. Adjust the seat position. Refer to "Front seats" 1-2.
2. Pull the tilt/telescopic lock lever down.
3. Move the steering wheel to the desired level.
4. Pull the lever up to lock the steering wheel in place.
5. Make sure that the steering wheel is securely locked by moving it up and down, and forward and backward.

Horn

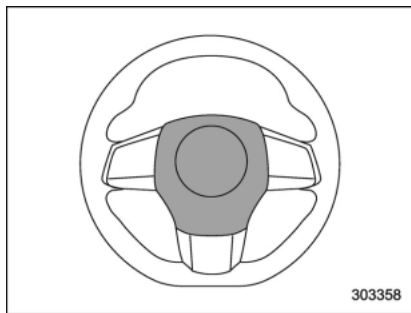

To sound the horn, push the horn pad.

Ventilator control	4-2	Operating tips for heater and air conditioner	4-9
Center and side ventilators	4-2	Cleaning ventilation grille.....	4-9
Climate control panel	4-3	Efficient cooling after parking in direct sunlight.....	4-9
Type A	4-3	Lubrication oil circulation in the refrigerant circuit.....	4-10
Type B	4-4	Checking air conditioning system before summer season	4-10
Automatic climate control operation	4-5	Cooling and dehumidifying in high humidity and low temperature weather conditions.....	4-10
Temperature sensors.....	4-5	Air conditioner compressor shut-off when engine is heavily loaded.....	4-10
Manual climate control operation	4-6	Refrigerant for your climate control system.....	4-10
Airflow mode selection.....	4-6	Air filtration system	4-11
Temperature control	4-7	Replacing an air filter.....	4-11
Fan speed control	4-8		
Air conditioner control	4-8		
Air inlet selection	4-8		
Defrosting	4-9		
Type A	4-9		
Type B	4-9		

Ventilator control

■ Center and side ventilators

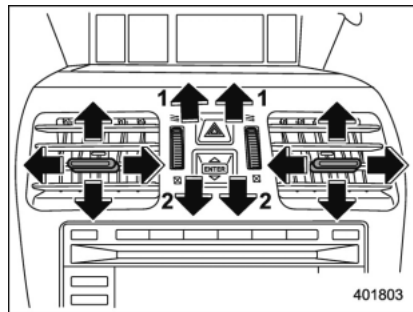

Center ventilators

- 1) Open
- 2) Close

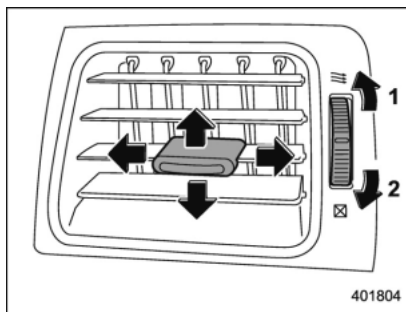

Side ventilators

- 1) Open
- 2) Close

To adjust the flow direction, move the tab.
To open or close the ventilator, turn the thumb-wheel up or down.

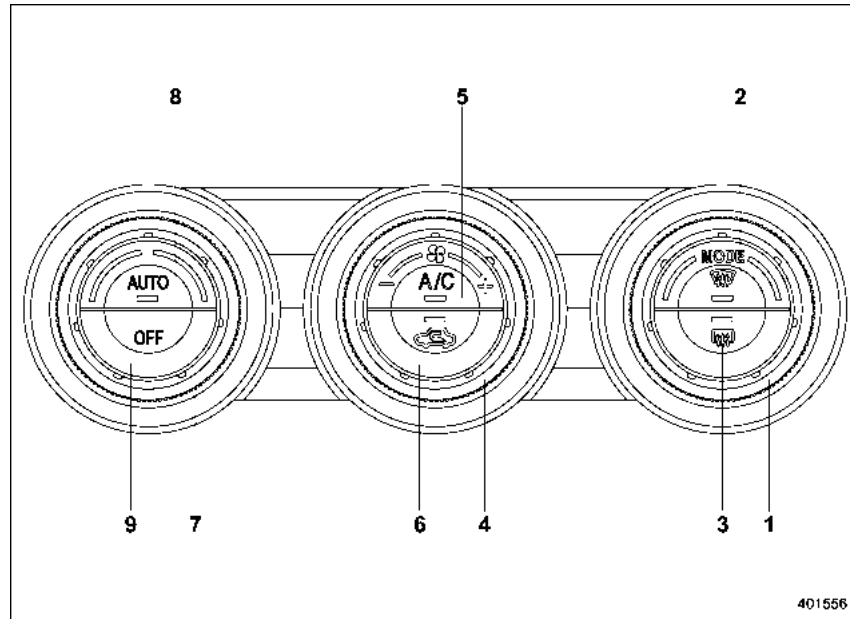
Climate control panel**■ Type A**

- 1) Airflow mode selection dial (Refer to "Airflow mode selection" ¶4-6.)
- 2) Defroster button (Refer to "Airflow mode selection" ¶4-6.)
- 3) Rear window defogger button (Refer to "Defogger and deicer" ¶3-114.)
- 4) Fan speed control dial (Refer to "Fan speed control" ¶4-8.)
- 5) Air conditioner button (Refer to "Air conditioner control" ¶4-8.)
- 6) Air inlet selection button (Refer to "Air inlet selection" ¶4-8.)
- 7) Temperature control dial (Refer to "Automatic climate control operation" ¶4-5 and/or "Temperature control" ¶4-7.)
- 8) AUTO button (Refer to "Automatic climate control operation" ¶4-5.)
- 9) OFF button (Refer to "Automatic climate control operation" ¶4-5.)

■ Type B

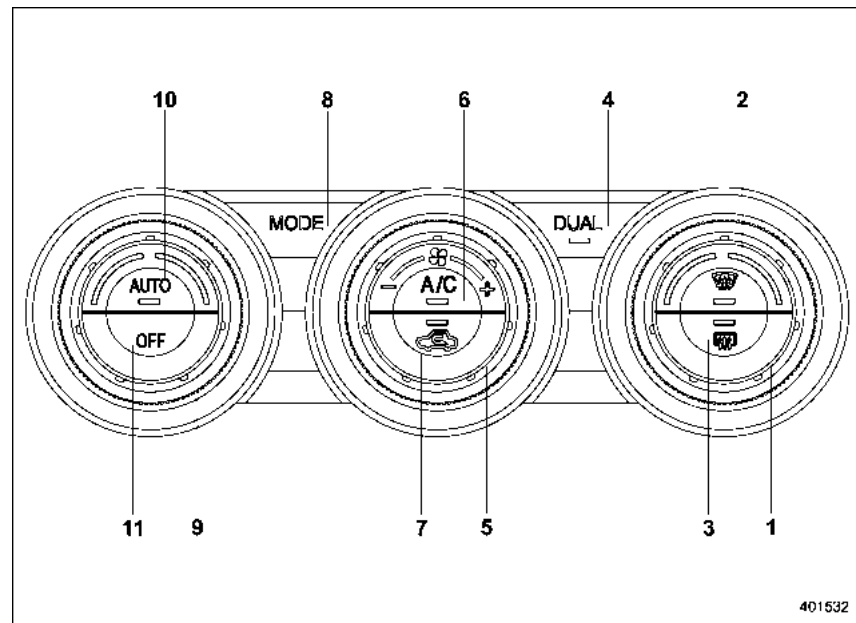

- 1) Temperature control dial (Refer to "Automatic climate control operation" 4-5 and/or "Temperature control" 4-7.)
- 2) Defroster button (Refer to "Airflow mode selection" 4-6.)
- 3) Rear window defogger button (Refer to "Defogger and deicer" 3-114.)
- 4) DUAL mode button (Refer to "DUAL" mode (type B)" 4-7.)
- 5) Fan speed control dial (Refer to "Fan speed control" 4-8.)
- 6) Air conditioner button (Refer to "Air conditioner control" 4-8.)
- 7) Air inlet selection button (Refer to "Air inlet selection" 4-8.)
- 8) Airflow mode selection button (Refer to "Airflow mode selection" 4-6.)
- 9) Temperature control dial (Refer to "Automatic climate control operation" 4-5 and/or "Temperature control" 4-7.)
- 10) AUTO button (Refer to "Automatic climate control operation" 4-5.)
- 11) OFF button (Refer to "Automatic climate control operation" 4-5.)

Automatic climate control operation

When this mode is selected, the fan speed, airflow distribution, air-inlet control, and air conditioner compressor operation are automatically controlled. To activate this mode, perform the following.

NOTE

- Operate the automatic climate control system when the engine is running.
- Even when cooling is not necessary, setting the temperature much lower than the current outlet air temperature turns on the air conditioner compressor automatically and the "A/C" indicator on the control panel illuminates.

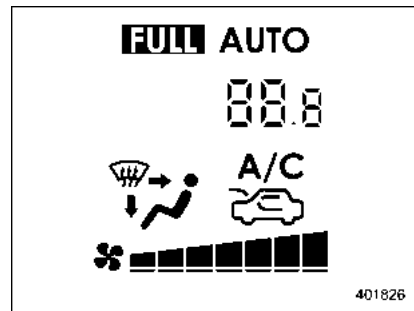

1. Depress the "AUTO" button. The indicator "FULL AUTO" on the display illuminates.
2. Set the preferred temperature using the temperature control dial.

NOTE

- The controllable temperature range may vary depending on the regional specifications of the vehicle.
 - If you operate any of the buttons on the control panel other than the "OFF" button, rear window defogger button and temperature control dial(s) during FULL AUTO mode operation, the "FULL" indicator on the control panel will turn off and the "AUTO" indicator will remain illuminated. You can then manually control the system as desired using the button you operated. To change the system back to the FULL AUTO mode, press the "AUTO" button.
 - When the climate control system turns off, the air inlet is fixed to the outside air mode.
3. To turn off the climate control system, press the "OFF" button.

Temperature sensors

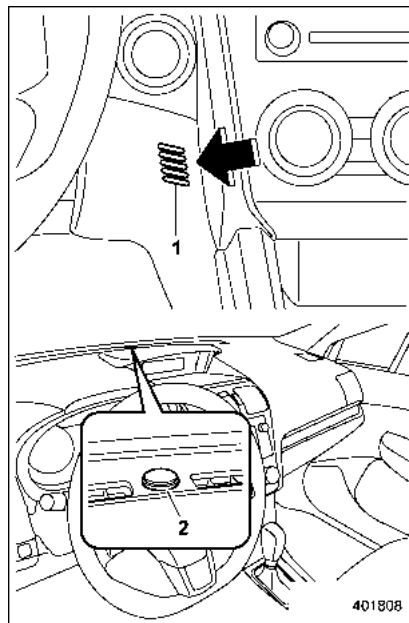

- 1) Interior air temperature sensor
- 2) Solar sensor

The automatic climate control system employs several sensors. These sensors are delicate. If they are not treated

properly and become damaged, the system may not be able to control the interior temperature correctly. To avoid damaging the sensors, observe the following precautions.

- Do not subject the sensors to impact.
- Keep water away from the sensors.
- Do not cover the sensors.

The sensors are located as follows.

- Solar sensor: beside the windshield defroster grille
- Interior air temperature sensor: next to the steering column
- Outside temperature sensor: near the front bumper opening

Manual climate control operation

■ Airflow mode selection

To select the airflow mode:

Type A: Turn the airflow mode selection dial.

Type B: Press the airflow mode selection button.

To select the defrost mode:

Press the defroster button.

Airflow modes are as follows.

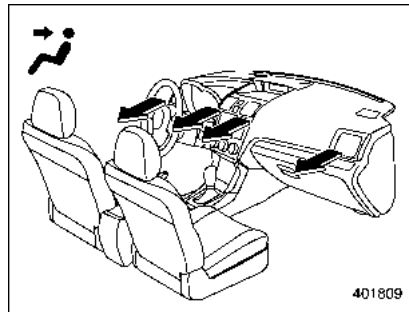

(Ventilation): Instrument panel outlets

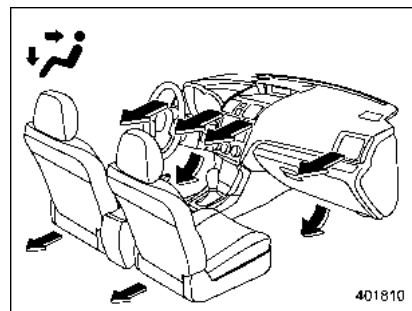

(Bi-level): Instrument panel outlets and foot outlets

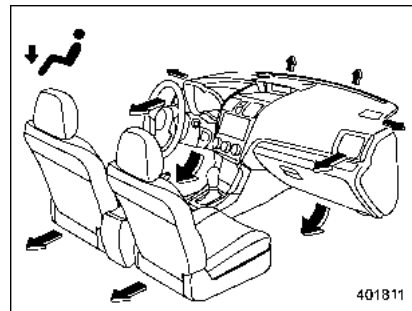

(Heat): Foot outlets, both side outlets of the instrument panel and some through windshield defroster outlets (A small amount of air flows to the windshield and

both side windows to prevent fogging.)

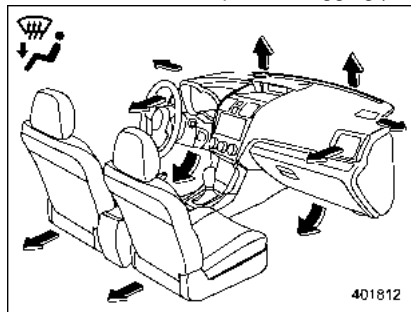

(Heat-def): Windshield defroster outlets, foot outlets and both side outlets of the instrument panel (Refer to “Defrosting” 4-9.)

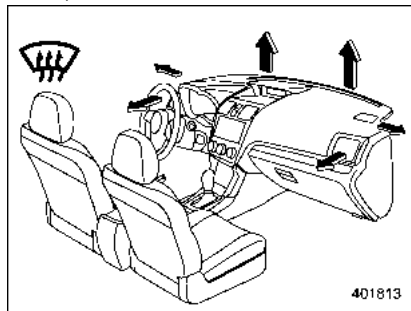

(Defrost): Windshield defroster outlets

and both side outlets of the instrument panel (Refer to “Defrosting” 4-9.)

NOTE

When the “” or “” mode is selected, the air conditioner compressor operates automatically regardless of the position of the air conditioner button to defrost the windshield more quickly. However the indicator on the air conditioner button will not illuminate. At the same time, the air inlet selection is automatically set to the outside air mode. After defrosting the windshield by pressing the defroster button “”, pressing the button again returns the system to the setting that had been selected before the defroster was activated.

■ Temperature control

Turn the temperature control dial to set the preferred interior temperature. With the dial set to your preferred temperature, the system automatically adjusts the temperature of air supplied from the outlets so that the preferred temperature is achieved and maintained.

If the dial is turned fully counterclockwise, the system provides maximum cooling performance. If the dial is turned fully clockwise, the system provides maximum

heating performance.

NOTE

The controllable temperature range may vary depending on the regional specifications of the vehicle.

▼ “DUAL” mode (type B)

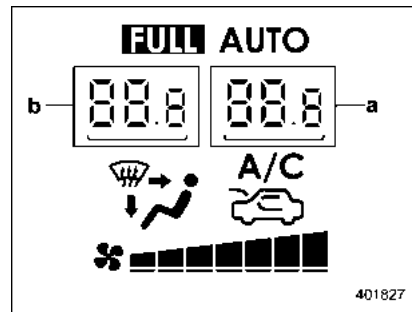

- a) Front passenger's side temperature
- b) Driver's side temperature

You can change the setting of the driver's side and front passenger's side temperature independently by selecting the “DUAL” mode.

You can select the “DUAL” mode by performing either of the following procedures.

- Press the “DUAL” button

- Turn the passenger's side temperature control dial

The "DUAL" mode can be canceled by pressing the "DUAL" button.

When the "DUAL" mode is selected:

Turn the driver's side dial to set the driver's side temperature. Turn the front passenger's side dial to set the front passenger's side temperature.

When the "DUAL" mode is canceled:

Set the desired temperature by turning the driver's side dial.

When the "DUAL" mode is canceled, only the driver's side temperature is displayed.

■ Fan speed control

The fan operates only when the ignition switch is in the "ON" position. Select the preferred fan speed by turning the fan speed control dial.

■ Air conditioner control

The air conditioner operates only when the engine is running.

Press the air conditioner button while the fan is in operation to turn on the air conditioner. When the air conditioner is on, the "A/C" indicator light illuminates.

To turn off the air conditioner, press the

button again.

NOTE

For efficient defogging or dehumidifying in cold weather, turn on the air conditioner. However, if the ambient temperature decreases to approximately 32°F (0°C), the air conditioner compressor will stop operating.

■ Air inlet selection

Select the air inlet by pressing the air inlet selection button.

ON position (recirculation): Interior air is recirculated inside the vehicle. Press the air inlet selection button to the ON position for fast cooling with the air conditioner or when driving on a dusty road.

OFF position (outside air): Outside air is drawn into the passenger compartment. Press the air inlet selection button to the OFF position when the interior has cooled to a comfortable temperature and the road is no longer dusty.

dusty.

NOTE

When the battery is disconnected or the battery voltage drops, the air inlet selection operation indicator light may blink. This does not indicate a malfunction. However, if the indicator light blinks every time you start the engine, a malfunction may occur in the electrical circuit. Have the vehicle inspected at the nearest SUBARU dealer.



WARNING

Continued operation in the ON position may fog up the windows. Switch to the OFF position as soon as the outside conditions are no longer

Defrosting

■ Type A

Select the “” mode by pressing the defroster button, or select the “” mode by turning the airflow mode selection dial to defrost or to dehumidify the windshield and front door windows.

■ Type B

Select the “” mode by pressing the defroster button, or select the “” mode by pressing the airflow mode selection button to defrost or to dehumidify the windshield and front door windows.

NOTE

When the “” or “” mode is selected, the air conditioner compressor operates automatically regardless of the position of the air conditioner button to defrost the windshield more quickly. However the indicator on the air conditioner button will not illuminate. At the same time, the air inlet selection is automatically set to the outside air mode. After defrosting the windshield by pressing the defroster button “”, pressing the button again returns the system to the setting that had been selected before the defroster was activated.

Operating tips for heater and air conditioner

■ Cleaning ventilation grille

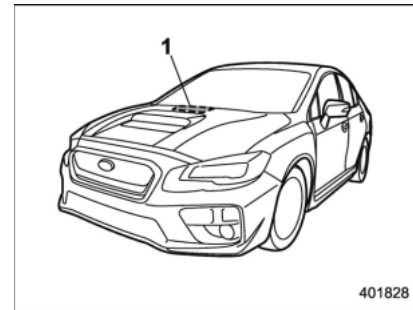

1) Front ventilation inlet grille

Always keep the front ventilation inlet grille free of snow, leaves, or other obstructions to ensure efficient heating and defrosting. Since the condenser is located in front of the radiator, this area should be kept clean because cooling performance is impaired by any accumulation of insects and leaves on the condenser.

■ Efficient cooling after parking in direct sunlight

After parking in direct sunlight, drive with the windows open for a few minutes to

allow outside air to circulate into the heated interior. This results in quicker cooling by the air conditioner. Keep the windows closed during the operation of the air conditioner for maximum cooling efficiency.

■ Lubrication oil circulation in the refrigerant circuit

Operate the air conditioner compressor at a low engine speed (at idle or low driving speeds) a few minutes each month during the off-season to circulate its oil.

■ Checking air conditioning system before summer season

Check the air conditioner unit for refrigerant leaks, hose conditions, and proper operation each spring. Have the air conditioning system checked by your SUBARU dealer.

■ Cooling and dehumidifying in high humidity and low temperature weather conditions

Under certain weather conditions (high relative humidity, low temperatures, etc.) a small amount of water vapor emission from the air outlets may be noticed. This condition is normal and does not indicate

any problem with the air conditioning system.

■ Air conditioner compressor shut-off when engine is heavily loaded

To improve acceleration and gas mileage, the air conditioner compressor is designed to temporarily shut off during air conditioner operation whenever the accelerator is fully depressed such as during rapid acceleration or when driving up a steep incline.

■ Refrigerant for your climate control system

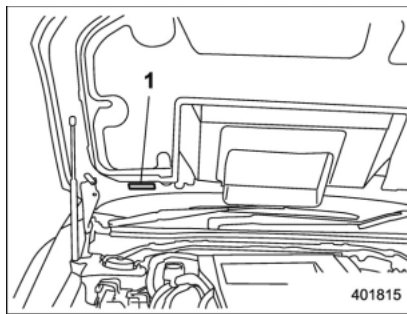

1) Air conditioner label

Your air conditioner uses ozone friendly

refrigerant HFC134a (as shown on the air conditioner label). Therefore, the method of adding, changing or checking the refrigerant is different from the method for CFC12 (freon). Consult your SUBARU dealer for service. Repairs needed as a result of using the wrong refrigerant are not covered under warranty.

Air filtration system

Replace the filter element according to the replacement schedule as follows. This schedule should be followed to maintain the filter's dust collection ability. Under extremely dusty conditions, the filter should be replaced more frequently. It is recommended that you have your filter checked or replaced by your SUBARU dealer. For replacement, use only a genuine SUBARU air filter kit. For the replacement schedule, refer to the "Warranty and Maintenance Booklet".



CAUTION

Contact your SUBARU dealer if the following occurs, even if it is not yet time to change the filter:

- Reduction of the airflow through the vents.
- Windshield gets easily fogged or misted.

NOTE

The filter can influence the air conditioning, heating and defroster performance if not properly maintained.

■ Replacing an air filter

1. Remove the glove box.
 - (1) Open the glove box.

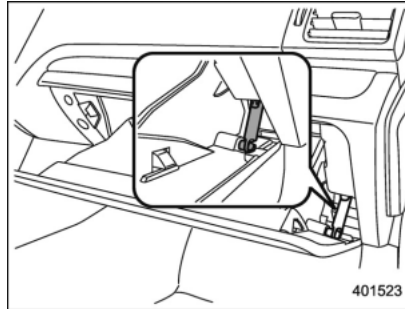

- (2) Remove the damper shaft from the glove box.

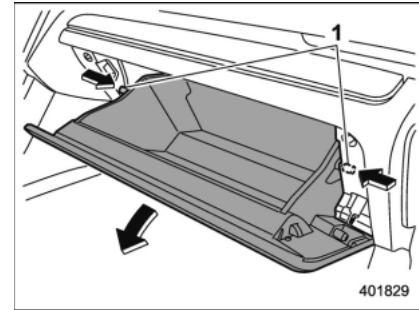

- 1) Stopper

- (3) Push both sides of the glove box inside to unlock the stoppers and then pull down the glove box as far as it will go.

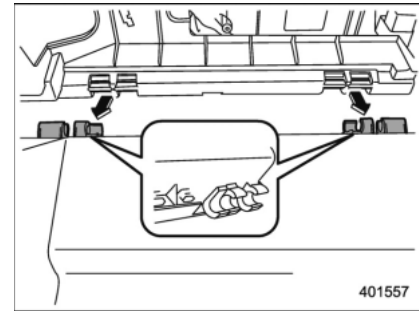

- (4) Pull out the glove box horizontally

4-12 Climate control/Air filtration system

and remove the hinge portion. When doing this, be careful not to damage the hinge.

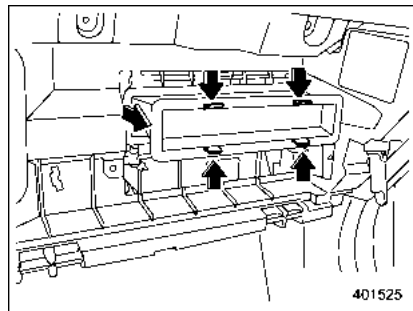

2. Remove the air filter. Pull the air filter out carefully and slant it up slowly to avoid dislodging the accumulated dust.

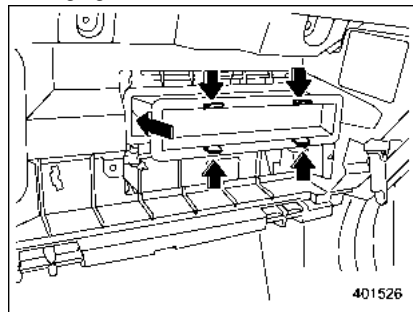

3. Replace the air filter element with a new one.

CAUTION

The arrow mark on the filter must point UP.

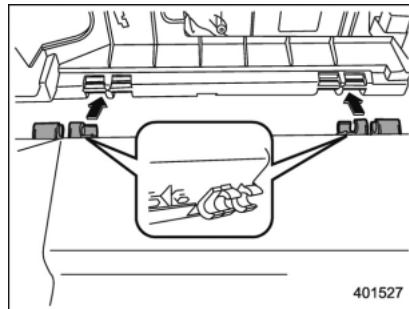

4. Reinstall the glove box, and connect the damper shaft.

5. Close the glove box.

6. Attach the service label to the driver's side door pillar.

Antenna system	5-3	To select a track from the beginning	5-18
Roof antenna	5-3	Fast-forwarding and rewinding	5-19
FM reception	5-3	Repeating	5-19
Installation of accessories	5-4	Random playback	5-20
Audio set	5-4	Scan	5-20
Type A audio set (if equipped)	5-5	Display selection	5-21
Type B audio set (if equipped)	5-6	Folder selection	5-21
Power and audio controls	5-7	How to eject a CD from the player	5-21
Power switch and volume control	5-7	When the following messages are displayed	5-22
Sound controls and audio settings	5-7	Auxiliary input jack	5-22
FM/AM radio operation	5-10	Precautions to observe when handling a compact disc	5-23
FM/AM selection (type B audio)	5-10	USB storage device / iPod® operations	5-25
FM selection (type A audio)	5-10	Play file	5-25
AM selection (type A audio)	5-10	Connectable USB storage device	5-25
Tuning	5-11	Connectable iPod® models	5-26
HD Radio™ Technology (Digital AM and FM Radio) (type B audio)	5-12	Connecting USB storage device / iPod®	5-26
Displaying radio PS (Program Service Name) and RT (Radio Text) (type B audio)	5-14	How to play back	5-27
Station preset	5-14	To select a track from the beginning	5-28
Satellite radio operation (type B audio)	5-15	To select a chapter from the beginning when connecting iPod®	5-28
Satellite radio reception	5-15	Fast-forwarding and rewinding	5-28
Displaying satellite radio ID of tuner	5-15	Repeating	5-28
Band selection	5-16	Random playback	5-29
Channel and category selection	5-16	SCAN (only when connecting USB storage device)	5-29
Channel preset	5-16	Selecting category (only when connecting iPod®)	5-30
Display selection	5-17	Display selection	5-30
CD player operation	5-17	Folder selection (only when connecting USB storage device)	5-30
Play file	5-17		
How to insert a CD	5-18		
How to play back a CD	5-18		

When "CHECK DEVICE" is displayed.....	5-30	Bluetooth® audio operation	5-34
Audio control buttons	5-31	Hands-free system	5-36
MODE button	5-31	Safety precautions	5-36
"∧" and "∨" switch.....	5-32	Using the Hands-free system	5-37
Volume control switch	5-32	Bluetooth® settings	5-52
Bluetooth® audio	5-33	Tips for the Hands-free system	5-54
Media format	5-33	Certification for the Hands-free system	5-56
Setting Bluetooth® audio	5-33		

Antenna system

■ Roof antenna

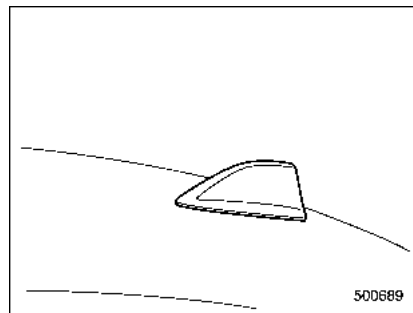

The shark-fin type roof antenna is installed in the center at the rear of the roof.

■ FM reception

Although FM is normally static free, reception can be affected by the surrounding area, atmospheric conditions, station strength and transmitter distance. Buildings or other obstructions may cause momentary static, flutter or station interference. If reception continues to be unsatisfactory, switch to a stronger station.

Installation of accessories

Always consult your SUBARU dealer before installing a citizen band radio or other transmitting device in your vehicle. Such devices may cause the electronic control system to malfunction if they are incorrectly installed or if they are not suited for the vehicle.

Audio set

Your SUBARU may be equipped with one of the following audio sets. Refer to the pages indicated in this section for operating details.

NOTE

If a cell phone is placed near the audio set, it may cause the audio set to emit noise when the phone receives calls. This noise does not indicate an audio set malfunction. Note that a cell phone should be placed as far as possible from the audio set.

■ Type A audio set (if equipped)

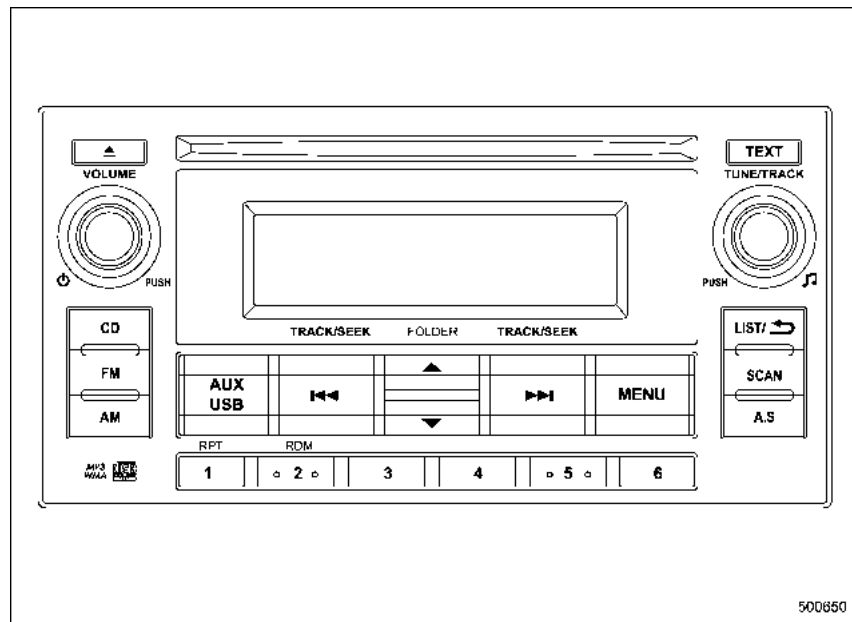

The audio set will operate only when the ignition switch is in the “ACC” or “ON” position.

- Power and audio controls: refer to page 5-7
- Radio operation: refer to page 5-10
- CD (compact disc) player operation: refer to page 5-17
- Auxiliary input jack: refer to page 5-22
- USB storage device/iPod® operation: refer to page 5-25
- Bluetooth® audio (if equipped): refer to page 5-33
- Hands-free system (if equipped): refer to page 5-36

■ Type B audio set (if equipped)

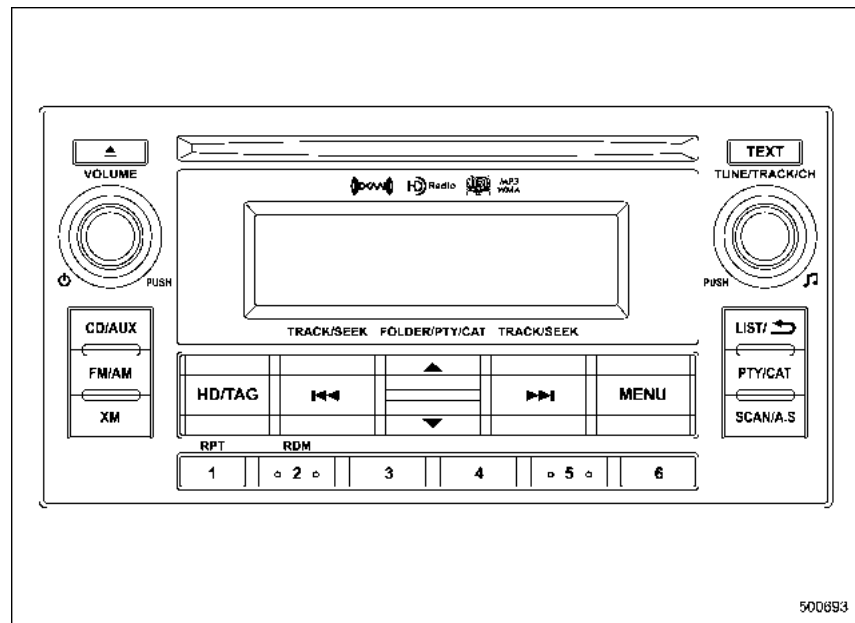

The audio set will operate only when the ignition switch is in the “ACC” or “ON” position.

- Power and audio controls: refer to page 5-7
- Radio operation: refer to page 5-10
- Satellite radio operation (if equipped): refer to page 5-15
- CD (compact disc) player operation: refer to page 5-17
- Auxiliary input jack: refer to page 5-22
- USB storage device/iPod® operation: refer to page 5-25
- Bluetooth® audio: refer to page 5-33
- Hands-free system: refer to page 5-36

NOTE

HD Radio Technology is included as a feature in the type B audio.

Power and audio controls

■ Power switch and volume control

Power and volume control dial



The dial is used for both power (ON/OFF) and volume control. The radio is turned ON and OFF by pressing the dial, and the volume is controlled by turning the dial.



■ Sound controls and audio settings

NOTE

This feature can be set via the multi function display unit. For details, refer to "Sound setting" 3-94.

▼ Tone and balance control

Sound control dial:

Type A audio	
Type B audio	

Each brief press of the sound control dial changes the control modes in the following sequence.

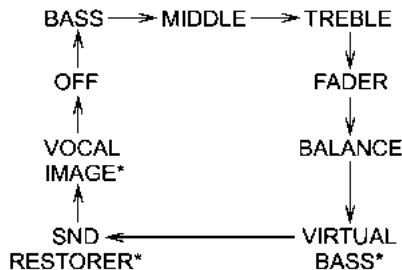

*: Except harman/kardon audio

Choose the preferred level for each mode by turning the sound control dial.

The control function returns to the tune/track control mode after approximately 8 seconds.

NOTE

- **VIRTUAL BASS** compensates for low pitch.
- **SND RESTORER** compensates for high pitch.
- **VOCAL IMAGE** controls the sound image localization.

▼ Other settings

"MENU" button	
---------------	---

Each brief press of the "MENU" button changes the control modes in the following sequence.

Type A audio:

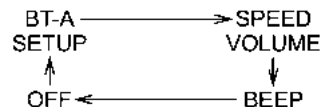

Type B audio:

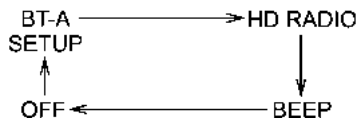

Choose the preferred settings for each mode by turning the sound control dial.

The control function returns to the tune/track control mode after approximately 8 seconds.

▽ **SVC setting (type A audio)**

SVC (Speed Volume Control) is a function that automatically adjusts the volume according to the vehicle speed. As the vehicle speed increases, the audio volume automatically increases to match the vehicle speed, in order to create a pleasant listening environment even as the driving noise increases. The amount of this automatic volume change can be set in the range from OFF to 2. The initial setting is OFF.

▽ **BEEP setting**

A beep sound (operation sound) that occurs when the audio system is operated can be set ON/OFF. The initial setting is ON.

▽ **HD Radio setting (type B audio)**

You can select the HD Radio ON mode (hybrid mode) or OFF mode (analog mode). The initial setting is ON.

▼ Adjustable level of each mode

Mode		Range of levels (displayed)	Default setting	Turn counterclockwise	Turn clockwise
Volume	Volume control	0 to 40	15	For less volume	For more volume
	AUX volume control	0 to 40	15	For less volume	For more volume
Tone and balance	Bass control	-8 to +8	0	For less bass sound	For more bass sound
	Midrange control	-8 to +8	0	For less midrange sound	For more midrange sound
	Treble control	-8 to +8	0	For less treble sound	For more treble sound
	Balance	L9 to R9	0	Right channel attenuated	Left channel attenuated
	Fader	R9 to F9	0	Front attenuated	Rear attenuated
	Virtual Bass control (except harman/kardon audio)	OFF to ON	ON	OFF	ON
	Sound Restorer (SND Restorer) (except harman/kardon audio)	OFF to ON	ON	OFF	ON
	Vocal image control (except harman/kardon audio)	L9 to R9	0	Right attenuated	Left attenuated
Other settings	SPEED VOLUME (type A audio)	OFF to 2	OFF	For less auto volume change	For more auto volume change
	BEEP	OFF to ON	ON	OFF	ON
	HD ON/OFF (Type B audio)	OFF to ON	ON	ON	OFF

FM/AM radio operation

NOTE

- If a cell phone is placed near the radio, it may cause the radio to emit noise when the phone receives calls. This noise does not indicate a radio malfunction.
- The selected reception mode and frequency will be displayed when either the "FM/AM" button (type B) or the "FM" button/"AM" button (type A) is pressed. When receiving a broadcast, the station name may be displayed. For details, refer to "Audio screen" 3-54.

■ FM/AM selection (type B audio)



Press the "FM/AM" button when the radio is off to turn on the radio.

Press the "FM/AM" button when the radio is on to select the preferred reception mode.

Each time the "FM/AM" button is briefly pressed, the radio will change in the following sequence starting from the last radio band that you selected.

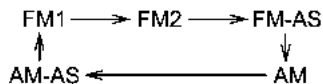

■ FM selection (type A audio)



Press the "FM" button when the radio is off to turn on the radio.

Press the "FM" button when the radio is on to select the preferred reception mode.

Each time the "FM" button is briefly pressed, the radio will change in the following sequence starting from the last radio band that you selected.

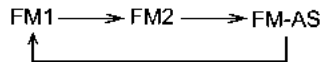

■ AM selection (type A audio)

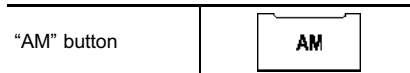

Press the "AM" button when the radio is off to turn on the radio.

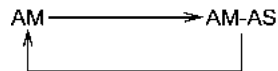

Each time the "AM" button is briefly pressed, the radio will change in the following sequence starting from the last radio band that you selected.



■ Tuning

▼ Manual tuning

“TUNE” dial:

Type A audio	
Type B audio	



Turn the “TUNE” dial clockwise to increase the tuning frequency and turn the “TUNE” dial counterclockwise to decrease it.

Each time the dial is turned, the frequency interval can be changed between 10 kHz in the AM mode and 0.2 MHz in the FM mode.

▼ Stereo indicator

The stereo indicator “ST” will illuminate when an FM stereo broadcast is received.

▼ Seek tuning (SEEK)

Seek up	
Seek down	

If you press the “◀◀” or “▶▶” side of the “SEEK” button briefly, the radio will automatically search for a receivable station and stop at the first one it finds.

This function may not be available when radio signals are weak. When this happens, perform manual tuning to select the preferred station.

▼ Scan tuning (SCAN)

“SCAN” button:

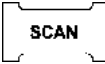
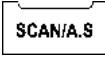
Type A audio	
Type B audio	

If you press the “SCAN” button briefly, the radio will switch to the scan mode. In this mode, the radio scans through the radio band until a receivable station is found. The radio will briefly stop at the station while displaying the frequency, after which scanning will continue until the entire band has been scanned.

Press the “SCAN” button again to cancel the SCAN mode and to stop at any displayed channel.

Automatic tuning may not function properly if the station reception is weakened by distance from the station or proximity to tall buildings and hills.



▼ **PTY (Program type) group tuning (only FM reception) (type B audio)**

"PTY" button	
--------------	---

Press the "PTY" button to change to the PTY selection mode. At this time, the PTY group that you are currently listening to will be displayed for 8 seconds. In the PTY selection mode, "PTY SEL" will be displayed on the screen.



▽ **PTY (Program type) group selection**



In the PTY selection mode, press the following button to change the PTY group by one step at a time.

PTY group up by one step	
PTY group down by one step	

This operation only changes the display. It does not change the station that is currently being received.

▽ **Seek in PTY (Program type) group**

Seek up	
Seek down	

In the PTY selection mode, when the preferred PTY group has been selected, pressing the "SEEK" button  or  seeks within that PTY group.

The control function returns to the normal mode after approximately 8 seconds.

■ **HD Radio™ Technology (Digital AM and FM Radio) (type B audio)**



HD Radio Technology is fueling the digital radio revolution in the United States and around the world.

The digital technology enables broadcasters to offer new and unique FM content via HD2 / HD3 channels, crystal-clear sound and data services on both AM and FM bands - all free, with no subscription fee.

HD Radio Technology manufactured under license from iBiquity Digital Corporation. U.S. and Foreign Patents. HD Radio™ and the HD, HD Radio, and "Arc" logos are proprietary trademarks of iBiquity Digital Corp.

For more information, visit www.hdradio.com.

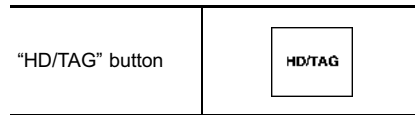

Press the "HD/TAG" button while receiving FM radio (except an analog broadcast). The next channel of the station that is being received will play.

▼ Mode selection

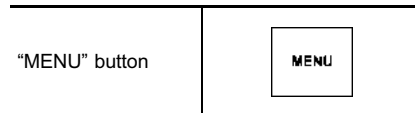

1. Press the "MENU" button to select the HD Radio setting mode.

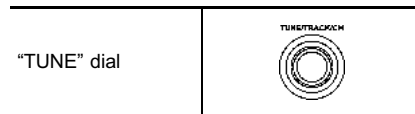

2. Turn the "TUNE" dial and select the HD Radio ON mode (hybrid mode) or OFF mode (analog mode).

▼ iTunes® tagging

To tag the received song, press and hold the "HD/TAG" button. Connect an iPod® to store the tagged song to the iPod®. When the iPod® is connected to iTunes®, you can purchase the tagged songs from the Apple® iTunes Music Store.

For the models of iPod® that support iTunes® tagging, refer to the following website: www.hdradio.com/tagging.php?id=itunes.

▼ HD Radio indicators

Each indicator illuminates under the following conditions.

- The "HD" indicator flashes while a digital broadcast is received during the HD Radio ON mode.
- The "TAG" indicator illuminates when you can operate the iTunes® tagging.
- The "LIVE" indicator illuminates when receiving a live broadcast, such as a ball game.
- The "ST" indicator illuminates when an FM stereo broadcast is received.
- The "PTY" indicator illuminates during the PTY selection mode.

▼ About HD Radio Technology

NOTE

- HD Radio Technology is a hybrid broadcasting system that employs di-

gital and analog signals.

- When the vehicle moves outside the digital broadcasting area (that is narrower than the analog broadcasting area due to the FCC output requirements), the radio reception automatically changes from the digital signal to the analog signal. When the vehicle reenters the digital broadcasting area, the radio reception automatically changes from the analog signal to the digital signal. When in a digital mode the  Logo will be in orange on the radio display.

- Depending on the broadcasting station, a condition such as a sound delay, echo effect or skipping sound may occur. However, this does not indicate a malfunction.

- Depending on the broadcasting area, the digital signal may not be received in an area where the analog signal can be properly received, or the system frequently switches the channels between the digital and analog signals. However, this does not indicate a malfunction. If this frequent switching between digital and analog causes annoyance, set the radio to the analog mode (HD Radio off mode) that provides the same radio broadcasting quality as a conventional radio.

■ Displaying radio PS (Program Service Name) and RT (Radio Text) (type B audio)

"TEXT" button	
---------------	---

Press the "TEXT" button to show the next page when the text is not fully displayed while the PSD (Program Service Data) or RT (Radio Text) service is received.

NOTE

- When the HD Radio function is turned on, PSD provides additional information about the broadcast. Text data such as "Title" and "Artist" is displayed on the screen.
- When the HD Radio function is turned off (HD Radio off mode), the radio text is displayed on the screen while receiving the broadcasting station with RBDS (Radio Broadcast Data System).

■ Station preset

▼ How to preset stations

1. Select the preferred reception mode.
2. Select the preferred station.
3. Press and hold one of the preset

buttons (from $\underline{\quad 1 \quad}$ to $\underline{\quad 6 \quad}$) to store the frequency. If the button is pressed briefly, the preceding selection will remain in the memory.

NOTE

- Up to six stations for each reception mode may be preset.
- If the connection between the radio and battery is broken for any reason such as vehicle maintenance or radio removal, all stations stored in the preset buttons are cleared. If this occurs, it is necessary to reset the preset buttons.

▼ Selecting preset stations

1. Select the preferred reception mode.
2. Press the preferred preset button (from $\underline{\quad 1 \quad}$ to $\underline{\quad 6 \quad}$) briefly.

▼ Auto-store

Auto-store button:

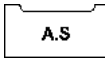
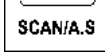
Type A audio	
Type B audio	

Using the Auto-store function, you can

automatically store 6 stations on the current waveband (FM-AS or AM-AS) by pressing and holding the auto-store button. Use Auto-store to quickly find the strongest stations, for example when traveling through different reception areas.



NOTE

- When the HD Radio function is turned on, Auto-store cannot be used while receiving a broadcasting station with SPS (Supplemental Program Service).
- When you use Auto-store, the new stations replace any stations previously stored.
- Interrupting Auto-store: If you accidentally press the auto-store button, you can cancel the Auto-store function before it has been completed as follows.
 - switching to the other source mode
 - pressing the auto-store button
 - switching to the other band
 - turning the "TUNE" dial
 - pressing the "SCAN" button (type A audio)

▼ **Displaying and selecting preset stations**

NOTE

The list of the preset broadcasting stations will be displayed when the “LIST” button is briefly pressed while receiving AM/FM. For details, refer to “Audio screen” 3-54.

“LIST” button	
“TUNE” dial (type A audio)	
“TUNE” dial (type B audio)	

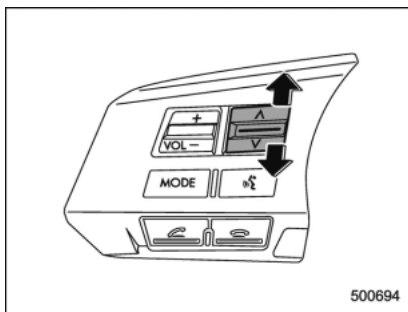

Seek switch

1. Briefly press the “LIST” button during AM/FM reception to display the radio screen.
2. Display the preferred preset station by performing either of the following procedures.
 - Turn the “TUNE” dial
 - Briefly press the seek switch to the “^” or “v” side
3. Press the “TUNE” dial to select the displayed station.

Satellite radio operation (type B audio)

■ **Satellite radio reception**

Satellite radio signals are best received in areas with a clear view of the open sky. In areas where there are tall buildings, trees, tunnels or other structures that may obstruct the signal of the satellites, there may be signal interruptions. Other circumstances that may result in signal loss include driving near a wall, steep cliff, hill or driving on the lower level of a multi-tiered road or inside of a parking garage.

To help reduce this condition, satellite radio providers have installed ground-based repeaters in heavily populated areas. However, you may still experience reception problems in some areas.

■ **Displaying satellite radio ID of tuner**

When you activate satellite radio, you should have your satellite radio tuner ID ready because each tuner is identified by its unique satellite radio tuner ID.

The satellite radio ID will be needed when you activate satellite radio and receive satellite radio customer support.

The satellite radio ID can be found on the audio display when satellite radio is

selected as the source.

Turn the "TUNE/TRACK/CH" dial to select the satellite radio channel.

■ Band selection

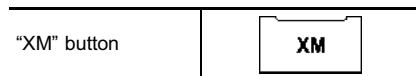

Push the "XM" button when the radio is off to turn on the radio.

Push the "XM" button when the radio is on to select XM1, XM2 or XM3 reception mode.

■ Channel and category selection

▼ Channel selection

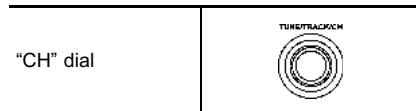

Turn the "CH" dial clockwise to select the next channel and turn the "CH" dial counterclockwise to select the previous channel.

▼ Category selection



To activate the category search mode, press the "PTY/CAT" button. To deactivate the category search mode, press the "PTY/CAT" button again.

When in the category search mode, press the following button to change the category up or down.

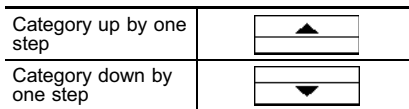

When a category is selected, turning the "TUNE/TRACK/CH" dial selects channels only within the selected category.

The control function returns to the normal mode after approximately 8 seconds.

▼ Channel scan



Press the "SCAN" button to change the radio to the SCAN mode. In this mode, under the selected category, the radio

scans through the channel until a station is found. The radio will stop at the station for 5 seconds while displaying the channel number, after which scanning will continue until the entire channel has been scanned.

Press the "SCAN" button again to cancel the SCAN mode and to stop on any displayed channel.

■ Channel preset

▼ How to preset channels

1. Press the "XM" button to select the preferred reception mode.
2. Select the desired channel.
3. Press and hold one of the preset buttons (from $\underline{\quad}$ 1 $\underline{\quad}$ to $\underline{\quad}$ 6 $\underline{\quad}$) for more than 1.5 seconds to store the channel. If the button is pressed and held for less than 1.5 seconds, the preceding selection will remain in memory.

NOTE

- Up to six channels for each reception mode may be preset.
- If the connection between the radio and battery is broken for any reason such as vehicle maintenance or radio removal, all channels stored in the preset buttons are cleared. If this occurs, it is necessary to reset the

preset buttons.

▼ Selecting preset channels

1. Press the “XM” button to select the preferred reception mode.
2. Press the preferred preset button (from **1** to **6**) briefly.

■ Display selection



Press the “TEXT” button while receiving the satellite radio to change the display as follows.

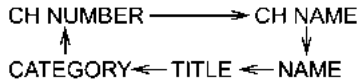

CD player operation

NOTE

- Make sure to always insert a disc with the label side up. If a disc is inserted with the label side down, the player displays “CHECK DISC”. Refer to “When the following messages are displayed” 5-22.
- If a disc is inserted during a radio broadcast, the disc will interrupt the broadcast.
- After the last song finishes, the disc will automatically return to track 1 (the first track on the disc) and will automatically play back.
- The player is designed to be able to play music CD-Rs and music CD-RWs, but it may not be able to play certain ones.
- Mini CDs (i.e., 8 cm/3 inch CDs) are not supported, and if inserted, they will be immediately ejected.
- CDs that can be played back are accompanied by the following restrictions.
 - Maximum number of folders: 255
 - Maximum number of files in a folder: 255

- Maximum number of files on a CD: 510

■ Play file

NOTE

- Copyright protected MP3/WMA/AAC files will not be played by the system. The player will automatically skip to the next file (track).
- WMA9 Lossless, WMA9 Professional and WMA9 voice cannot be played.

MP3:

- Based on MPEG1, 2 and 2.5 Layer3
- Sampling rate (kHz): 48, 44.1, 32, 24, 22.05, 16, 12, 11.025, 8
- Bit rate (kbps): 8 to 320
- Supports variable bit rates

WMA:

- Based on Windows Media Audio 9
- Sampling rate (kHz): 48, 44.1, 32
- Bit rate (kbps): 32 to 192

AAC:

- Based on MPEG4 AAC
- Sampling rate (kHz): 48, 44.1, 32, 24, 22.05, 16, 12, 11.025, 8
- Bit rate (kbps): 8 to 320
- Number of channels: 1 to 2ch

■ How to insert a CD

Hold a disc with a finger in the center hole while gripping the edge of the disc, then insert it in to the slot (with the label side up) and the player will automatically pull the disc into position.

NOTE

DO NOT INSERT TWO DISCS INTO THE DISC INSERTION SLOT AT THE SAME TIME.

■ How to play back a CD

NOTE

The following information will be displayed while playing a CD.

- Album name (except when playing an MP3/WMA/AAC file)
- Folder name (when playing an MP3/WMA/AAC file)
- Artist name
- Song title

For details, refer to “Audio screen” 3-54.

▼ When there is no CD inserted

Properly insert a CD. Refer to “How to insert a CD” 5-18.

When a CD is loaded, the player will start playback of the CD, beginning with the

first track.

▼ When CD is in the player (type A)

When the  button is pressed, the player will start playback.



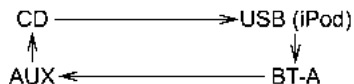

▼ When CD is in the player (type B)

Each brief press of the  button changes the modes in the following sequence.



When the CD mode is selected, the player will start playback.

■ To select a track from the beginning

“TRACK” dial (type A audio)	
“TRACK” dial (type B audio)	
Skip to the beginning of the next track	
Skip to the beginning of the current track	

Use either of the following methods to skip to the beginning of the next track. Each time, the indicated track number will increase.

- Turn the “TRACK” dial clockwise.
- Press the  button briefly.

Use either of the following methods to skip to the beginning of the current track. Each time, the indicated track number will decrease.



- Turn the “TRACK” dial counterclockwise.
- Press the “⏮” button briefly.

NOTE

With an MP3, WMA or AAC:

- Skipping past the last track will take you back to the first track in the folder.
- Skipping past the first track will take you to the last track in the folder.

■ Fast-forwarding and rewinding

Fast-forwarding	
Rewinding	

Press and hold the “▶▶” button to fast-forward the track. Release the button to stop fast-forwarding.

Press and hold the “◀◀” button to rewind the track. Release the button to stop rewinding.

NOTE

- If you fast-forward to the end of the last track, fast-forwarding will stop and the player will start playback beginning with the first track. For an MP3, WMA or AAC folder, the player will start playback beginning with the first track of the next folder.
- If you rewind to the beginning of the first track, rewinding will stop and the player will start playback. For an MP3, WMA or AAC folder, the player will start playback beginning with the first track of the current folder.

■ Repeating

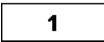
“RPT” button	
--------------	---

To repeat a track, briefly press the “RPT” button while the track is playing.

Each time you briefly press the button, the mode will change in the following sequences.

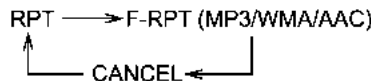

NOTE

- The “RPT” indication refers to the repeat playback of a single track. It repeats the track that is playing.
- The “F-RPT” indication refers to the repeat playback of a folder. It repeats the all of the tracks in the folder. It is possible to select the function when the MP3/WMA/AAC format track is playing.

To cancel the track repeat-play mode, briefly press the “RPT” button and select CANCEL. The “RPT” indicator will turn off, and the normal playback mode will be resumed.

NOTE

The repeat-play mode will be cancelled if you perform any of the following steps.

- Press the “RPT” button and select CANCEL.
- Press the “RDM” button.
- Press the “▲” button.
- Press the “SCAN” button (type A audio).
- Press the “SCAN/A.S” button (type B audio).

■ Random playback

"RDM" button	<div style="border: 1px solid black; padding: 5px; width: fit-content; margin: 0 auto;"> RDM ○ 2 ○ </div>
--------------	--

To playback tracks at random, briefly press the "RDM" button while a track is playing.

Each time you briefly press the button, the mode will change in the following sequences.

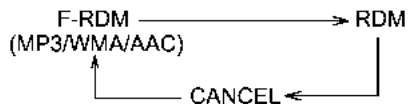

NOTE

- The "RDM" indication refers to the random playback of the tracks. It randomly repeats the tracks on the CD. It is possible to select the function when formats other than the MP3/WMA/AAC format CD is playing.

- The "F-RDM" indication refers to the random playback in the folder. It randomly repeats the tracks in the folder. It is possible to select the function when an MP3/WMA/AAC format track is playing.

To cancel the random playback mode, briefly press the "RDM" button again and select CANCEL.

The "RDM" indicator will turn off, and the normal playback mode will be resumed.

NOTE

Random playback will be cancelled if you perform any of the following steps.

- Briefly press the "RDM" button and select CANCEL.
- Press the "RPT" button.
- Press the "▼" or "▲" side of the "FOLDER" button (only when an MP3/WMA/AAC format track is playing).
- Press the button.
- Press the "SCAN" button (type A audio).
- Press the "SCAN/A.S" button (type B audio).

■ Scan

Type A audio	<div style="border: 1px solid black; padding: 5px; width: fit-content; margin: 0 auto;"> SCAN </div>
Type B audio	<div style="border: 1px solid black; padding: 5px; width: fit-content; margin: 0 auto;"> SCAN/A.S </div>

The scan mode lets you listen to the first 10 seconds of each track in succession. Press the "SCAN" button to start scanning

upward beginning with the track following the currently selected one.

After all tracks on the disc/in the folder have been scanned, normal playback will be resumed. To cancel the scan mode, press the "SCAN" button again.

NOTE

• The scan mode will be cancelled if you perform any of the following steps.

- Press the "RPT" button.
- Press the "RDM" button.
- Turn the "TRACK" dial.
- Press the "▼" or "▲" side of the "FOLDER" button (only when an MP3/WMA/AAC track is playing).
- Press the "▶▶" or "◀◀" side of the "TRACK/SEEK" button.
- Press the "SCAN" button (type A audio).
- Press the "SCAN/A.S" button (type B audio).
- Select the radio or AUX mode.
- Turn off the power of the audio equipment.
- Turn the ignition switch to the "LOCK"/"OFF" position.

- When the "SCAN" button (type A audio)/"SCAN/A.S" button (type B audio) is pressed while the MP3, WMA or AAC format data is played back, the system scans within the current folder.

- When the "SCAN" button (type A audio)/"SCAN/A.S" button (type B audio) is pressed while data (except for the MP3, WMA or AAC formats) is played back, the system scans the disc.

■ Display selection

"TEXT" button	<div style="border: 1px solid black; padding: 2px; display: inline-block;">TEXT</div>
---------------	---

If you press the "TEXT" button during playback, the display will change as shown in the following sequence.

For CD-DA:

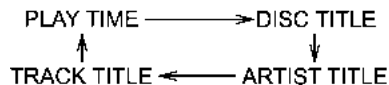

For MP3/WMA/AAC:

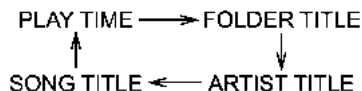

For iPod® (when playing music):

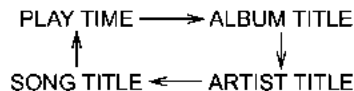

For iPod® (when playing audiobook):

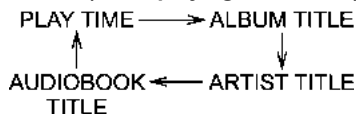

For iPod® (when playing podcast):

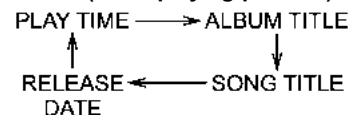

▼ Page (track/folder title) scroll

If you press the "TEXT" button again and hold it, the title will be scrolled so you can see all of it.

NOTE

- The display is designed to show titles of up to 24 characters.
- If no operations are performed for 10 seconds, the screen that was displayed before pressing and holding the "TEXT" button will be shown.

■ Folder selection

NOTE

Only MP3/WMA/AAC folders are recognized when an attempt to select the next or previous folder is made. If no appropriate folder exists on the disc, pressing the "▲" or "▼" side of the "FOLDER" button starts playback beginning with the first track.

Press the following buttons briefly.

To select the next folder	<div style="border: 1px solid black; padding: 2px; display: inline-block;">▲</div>
To go back to the previous folder	<div style="border: 1px solid black; padding: 2px; display: inline-block;">▼</div>

■ How to eject a CD from the player

When a disc is being played back or when a disc is in the player, press the  button. The disc will be ejected.

NOTE

- Avoid driving the vehicle with a CD sticking out. The CD may fall out due to vibration.
- If you do not remove the ejected disc within approximately 15 seconds, a disc protection function will operate, automatically reloading the disc. In this case, the disc is not played.

■ When the following messages are displayed

If one of the following messages is displayed while operating the CD player, determine the cause based on the following information. If you cannot clear those messages, please contact your SUBARU dealer.

▼ When “PUSH EJECT” is displayed

Press the  button to eject the disc. Check the disc for damage or deformation, and also check that the correct disc is inserted. Do not try to eject the disc forcibly. Mini CDs (e.g., 8 cm/3 inch CDs) are not supported, and if inserted, they will be immediately ejected and this message will be displayed. If the disc cannot be ejected or this message remains displayed, please contact your SUBARU dealer.

▼ When “CHECK DISC” is displayed

Press the  button to eject the disc. Check that the disc is not damaged or scratched, and also check that the disc is inserted correctly. This message may appear when using some CD-RW discs. Check that the disc type (e.g., 8 cm/3 inch CDs are not supported) and data format are correct. This player can only play MP3, WMA and AAC data formats. If the disc cannot be ejected or this message

remains displayed, please contact your SUBARU dealer.

Auxiliary input jack

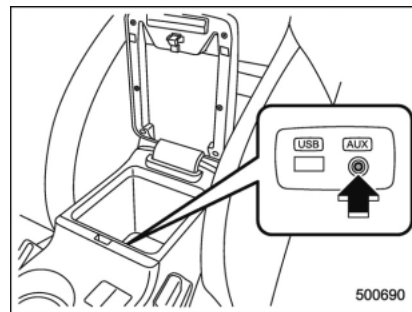

You can connect an external audio device to the vehicle's audio system and play back audio via the vehicle's speakers.

An auxiliary (AUX) input jack is present in the center console. A stereo mini pin plug (3.5 ϕ) can be inserted in this jack. The connection cable is available at electrical appliance or similar stores.

To use the AUX input jack:

1. Connect a portable audio player to the AUX input jack.

AUX input selection button:

Type A audio	
Type B audio	

2. Press the AUX input selection button on the audio control panel to select the AUX mode. For type B audio, refer to “When CD is in the player (type B)” 5-18.

3. Play back the portable audio player. Refer to the instruction manual for the portable audio player.

NOTE

- For models with the genuine SUBARU navigation system, refer to the Owner’s Manual supplement for the navigation system for details.
- The output sound of the portable audio player is not loud, and the sound via the vehicle’s speakers that are connected to the vehicle audio set may be very low. If you turn up the volume of the audio set, the volume becomes louder. However, when you change from one portable audio player to another one, the volume levels via the vehicle’s speakers may be signifi-

cantly louder compared to the prior device. To avoid a large volume difference, turn down the volume when you change between portable audio players.

- In some cases, when the sound volume of the portable audio player is low, the sound quality may become impaired when you turn up the volume of the vehicle audio system. In this case, adjust the sound volume of the portable audio player.

- In some cases, noise occurs because of a bad connection between the portable player and the vehicle audio system. Try cleaning the stereo jack and audio plug.

- If the noise is not reduced, check for disconnection of the cord or a malfunction of the portable player.

Precautions to observe when handling a compact disc

Use only compact discs (CDs, CD-Rs and CD-RWs) that have the mark shown in the following. Also, some compact discs cannot be played.



- You cannot use a DualDisc in the CD player. If you insert a DualDisc into the player, the disc may not come out again, possibly causing the player to malfunction.
- In cold and/or rainy weather, dew can form inside the CD player, preventing normal operation. If this happens, eject the CD and wait for the player to dry out.
- Skipping may occur when the CD player is subjected to severe vibration (for example, when the vehicle is driven on a rough surface).
- To remove a disc from the case, press the center of the case and hold both edges of the disc. If the disc surface is touched directly, contamination could cause poor tone quality. Do not touch the disc surface.
- Use a clean disc whenever possible. If

there are deposits, wipe the disc surface from the center outward with a dry, soft cloth. Be sure not to use a hard cloth, thinner, benzine, alcohol, etc.

- Do not use any disc that is scratched, deformed, or cracked. Also, do not use any disc that has a non-standard shape (for example, a heart shape). Malfunctions or problems might result.
- A disc is vulnerable to heat. Never keep it either in places exposed to direct sunlight, near heaters or in vehicles parked in the sun or on hot days.

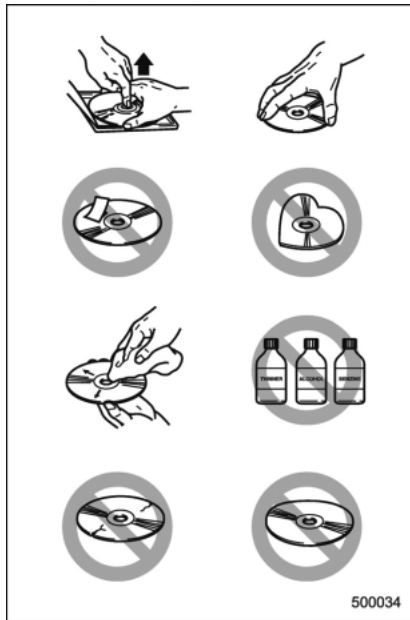

USB storage device / iPod® operations

NOTE

For models with the genuine SUBARU navigation system, refer to the Owner's Manual supplement for the navigation system.

■ Play file

Refer to "Play file" 5-17.

■ Connectable USB storage device

Mass storage class USB memory can be connected. USB storage devices that can be played back are accompanied by the following restrictions.

- Maximum directory layers: 8 layers (including the ROOT)
- Maximum number of files in a folder: 255
- Maximum number of folders: 512 (including the ROOT)
- Maximum number of files on the device: 130,560
- Maximum capacity: 16 GB or less

NOTE

- HUB class USB memory cannot be played.
- ATAPI subclass USB cannot be played.
- For type A audio, High Speed USB 2.0 cannot be played.
- A USB memory that is powered by a source other than the USB power supply (for example, an AC power adapter, etc.) cannot be operated.
- A USB memory that is connected to the memory card reader or multi card reader cannot be operated.
- If the USB memory consists of two drives or more, the system will recognize only one of the drives after connecting the USB memory.
- The contents stored on the USB memory may not be played in the same order as they appear on a personal computer.
- A personal computer cannot be used even if it is connected to the system using a USB cable.
- If the USB memory has a security function, the contents stored on the USB memory cannot be played by the system.
- A USB memory and an iPod® cannot be connected to the system at the same time.

■ Connectable iPod® models

	Model	Firmware version
iPod®	with video	1.3
	classic	2.0.4
	nano 1G	1.3.1
	nano 2G	1.1.3
	nano 3G	1.1.3
	nano 4G	1.0.4
	nano 5G	1.0.2
	nano 6G	1.0
	touch 1G	3.1.3
	touch 2G	3.1.3
	touch 3G	4.1
touch 4G	4.1	
iPhone®	1G	3.1.3
	3G	3.1.3
	3G S	3.1.3
	4	4.1
	4S	5.0



CAUTION

Do not connect an iPod® other than the previously stated models. Doing so may result in a malfunction or,

depending on conditions, cause a fire.

NOTE

- iPod® is a registered trademark of Apple Inc.
- You are only permitted to personally copy and play copyright-free material or material that is legally permitted to be copied and played by using an iPod® and iTunes. Copyright infringement is prohibited by law.
- To check the firmware version of an iPod®, connect it to a computer and check the device manager. For further information, see the User's Guide for the iPod®.
- To update the firmware version of an iPod®, visit the Apple Inc. website.
- Depending on the model and firmware version of an iPod®, it may not work properly or not operate at all.

■ Connecting USB storage device / iPod®



WARNING

Do not operate an iPod® while driving. Doing so may distract your attention from driving and could lead to an accident.



CAUTION

- If the data stored in an iPod® is deleted while it is connected to the in-vehicle system, the data cannot be recovered.
- Do not store an iPod® in the vehicle. If an iPod® is left in the vehicle for a long period of time, it may be deformed, discolored or damaged by high temperature.

NOTE

- Even if a USB storage device or iPod® is connected, it cannot be played unless the USB/iPod® mode is selected.
- Movies stored on a USB storage device or an iPod® cannot be played while the storage device or iPod® is connected to the system.

- While an iPod® is connected, the iPod® cannot be operated using the click wheel on the iPod® (except some models).
- When using an iPod® by connecting it to in-vehicle equipment, the order of the list items displayed on the in-vehicle equipment may be different from that on the iPod®. However, this does not indicate a malfunction.
- An iPod® battery that is connected to in-vehicle equipment will be charged when the ignition switch is in the “ON” or “ACC” position. However, activation of the iPod® may be delayed if the battery charge of the iPod® is low.
- If an iPod® does not activate after operation, disconnect the connection cable from the iPod® and reset it. For the resetting procedure, see the User’s Guide of the iPod®.
- If an iPod® and the connection cable are connected improperly, the iPod® cannot be powered on or will not be recognized by in-vehicle equipment. In this case, disconnect the connection cable from the iPod®, and then connect it again.

- Depending on the model of iPod® connected, the “RPT” indicator may illuminate regardless of the user settings. However, this is not a malfunction.

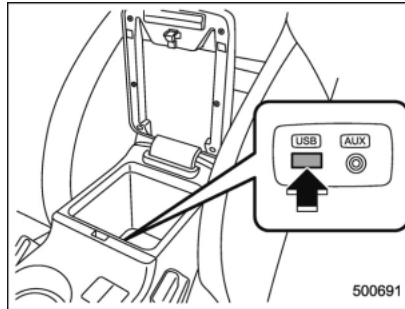

The USB connector is located in the center console. Use the connector to connect a USB storage device/iPod®.

■ How to play back

NOTE

The following information will be displayed while using a USB storage device/iPod®.

- Folder name (when using a USB storage device)
- Album name (when using an iPod®)
- Artist name

- Song title (when using a USB storage device or playing a music with an iPod®)
- Audiobook name (when playing an audiobook with an iPod®)
- Date of Podcast (when playing a podcast with an iPod®)

For details, refer to “Audio screen” 3-54.

1. Connect a USB storage device/iPod®. Playback button:

Type A audio	AUX USB
Type B audio	CD/AUX

2. Press the playback button. Each time you briefly press the button, the mode will change in the following sequence.

Type A audio:

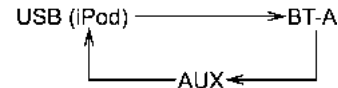

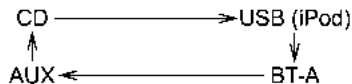
Type B audio:

When the USB/iPod® mode is selected, the player will start playback of the USB storage device/iPod®.

NOTE

- Depending on the number of files stored on the iPod® and the firmware version, the iPod® may not activate smoothly after operation or not work properly.
- Do not disconnect the connector from the iPod® during iPod® operation.

■ To select a track from the beginning

Select a track in the same way as for a CD. For details, refer to “To select a track from the beginning” 5-18.

■ To select a chapter from the beginning when connecting iPod®

When playing podcasts or audiobooks, select a chapter in the same way as described in “To select a track from the

beginning” 5-18.

■ Fast-forwarding and rewinding

Fast-forwarding and rewinding are operated in the same way as for a CD. For details, refer to “Fast-forwarding and rewinding” 5-19.

NOTE

When connecting iPod®:

- When the end of a track is reached while fast-forwarding, fast-forwarding will end and playback will begin from the beginning of the next track.
- When the beginning of a track is reached while rewinding, rewinding will end and playback will begin from the beginning of the track.

■ Repeating**▼ When connecting USB storage device**

Repeating is operated in the same way as for a CD. For details, refer to “Repeating” 5-19.

▼ When connecting iPod®

	RPT
“RPT” button	1

Each time you briefly press the “RPT” button, the mode will change in the following sequence.

ALL RPT ← → SONG RPT

NOTE

- The “ALL RPT” indication refers to the repeat playback of all tracks on the entire iPod®.
- The “SONG RPT” indication refers to the repeat playback of a single track. It repeats the track that is playing.
- When an audiobook is playing, the mode does not change even if you press the “RPT” button.

■ Random playback

"RDM" button	<div style="border: 1px solid black; padding: 5px; display: inline-block;"> RDM ◦ 2 ◦ </div>
--------------	---

To playback tracks at random, briefly press the "RDM" button while a track is playing.

Each time you briefly press the button, the mode will change in the following sequence.

When connecting USB storage device:

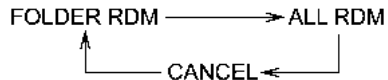

When connecting iPod®:

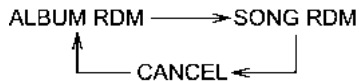

NOTE

- The "FOLDER RDM" indication refers to the random playback in the folders. It randomly repeats all of the tracks in the folder.
- The "ALL RDM" indication refers to the random playback on the entire USB storage device. It randomly repeats all

of the tracks on the USB storage device.

- The "ALBUM RDM" indication refers to the shuffle playback of the album. It sequentially plays back all of the tracks on the album.
- The "SONG RDM" indication refers to the shuffle playback on the entire iPod®. It randomly repeats all of the tracks on the iPod®.
- When an iPod® is connected, the files are played back at random by the shuffle function of the iPod®. Therefore, iPod® operation may be different depending on the model of the connected iPod®.
- When an audiobook or a podcast is playing, the mode does not change even if you briefly press the "RDM" button.

To cancel the random playback mode, briefly press the "RDM" button and select CANCEL. The "RDM" indicator will turn off, and the normal playback mode will resume.

■ SCAN (only when connecting USB storage device)

"SCAN" button:



Type A audio	<div style="border: 1px solid black; padding: 5px; display: inline-block;"> SCAN </div>
Type B audio	<div style="border: 1px solid black; padding: 5px; display: inline-block;"> SCAN/A.S </div>

Scan is operated in the same way as for a CD. For details, refer to "Scan" 5-20.

NOTE

When an iPod® is connected, you cannot select the SCAN mode.

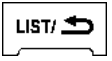
■ Selecting category (only when connecting iPod®)

"LIST" button	
"TRACK" dial (type A audio)	
"TRACK" dial (type B audio)	

When the "LIST" button is pressed briefly, the iPod® menu will be displayed.

Each time you turn the "TRACK" dial clockwise, the displayed category will change in the following sequence. Each time you turn the dial counterclockwise, the displayed category will change in the opposite sequence.

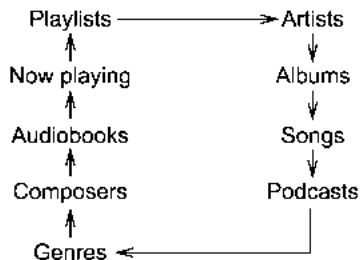

To select the category, press the dial. To close the iPod® menu, press and hold the "LIST" button. To return to the previous screen, briefly press the "LIST" button.

■ Display selection

Refer to "Display selection" 5-21.

▼ Page scroll

Refer to "Page (track/folder title) scroll" 5-21.

■ Folder selection (only when connecting USB storage device)

Refer to "Folder selection" 5-21.

NOTE

When an iPod® is connected, you cannot select a folder.

■ When "CHECK DEVICE" is displayed

This message is displayed under the following conditions.

- When there is a short in the USB bus
- When an unsupported device (for example a USB mouse) is connected
- When an unsupported iPod® is connected
- When a connected iPod® is frozen
- When a transmission malfunction occurs
- When an iPod® confirmation malfunction occurs
- When a HUB class USB storage device is connected

Disconnect the USB storage device/iPod® and check it.

Audio control buttons

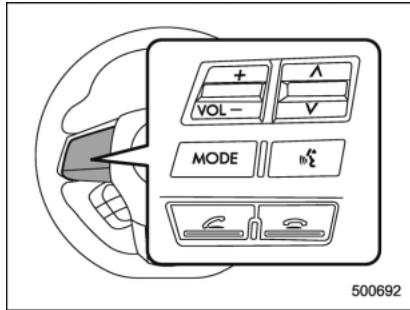

These buttons are located on the spokes of the steering wheel. They allow the driver to control audio functions without taking his/her hands off the steering wheel.

MODE button

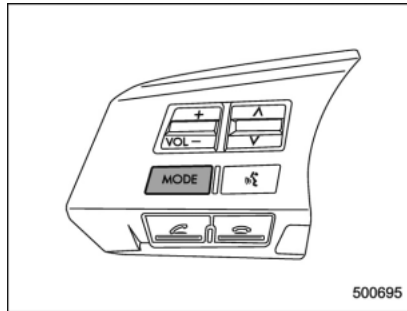

The "MODE" button is used to select the preferred audio mode. Each time it is pressed, the mode will change to the next one in the following sequence:

Type A audio:

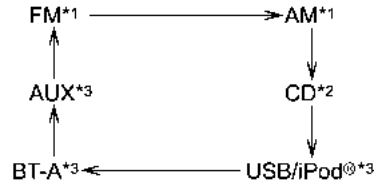

*1: The frequency last received in the selected waveband will be displayed.

*2: Only when a CD is in the player.

*3: Only when the device is connected

Type B audio:

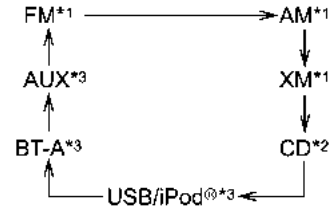

*1: The frequency last received in the selected waveband will be displayed.

*2: Only when a CD is in the player.

*3: Only when the device is connected.

Press and hold this button if you wish to immediately cut the volume to zero.

The audio display will show "MUTE".

If you press and hold the button again, the original sound volume will return and "MUTE" turns off.

■ “^” and “v” switch

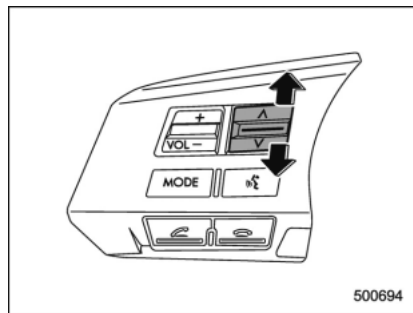

▼ With radio mode selected

Press the switch to the “^” or “v” side briefly to skip to a preset channel. Press and hold the switch to the “^” or “v” side to seek the next receivable station and stop at it.

That station’s frequency will be indicated on the audio display.

▼ With CD mode selected

Press the switch to the “^” side briefly to skip forward in the track order. Press the switch to the “v” side briefly to skip backward in the track order.

The track number will be shown on the audio display.

When the MP3/WMA/AAC format track is

playing, press and hold the switch to the “^” side to select the next folder. Press and hold the switch to the “v” side to go back to the previous folder.

▼ With USB/iPod®/Bluetooth® audio mode selected

Press the switch to the “^” side briefly to skip forward in the track order. Press the switch to the “v” side briefly to skip backward in the track order. The track number will be shown on the audio display.

When the USB/Bluetooth® audio mode is selected, press and hold the switch to the “^” side to select the next folder. Press and hold the switch to the “v” side to go back to the previous folder.

■ Volume control switch

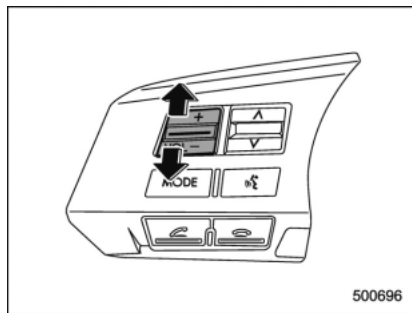

Press the switch to the “+” side to increase the volume. Press the switch to the “-” side to reduce the volume.

A number indicating the volume will be shown on the audio display.

Bluetooth® audio

NOTE

For models with the genuine SUBARU navigation system, refer to the Owner's Manual supplement for the navigation system.

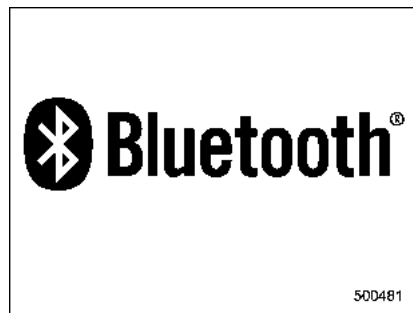

NOTE

The Bluetooth word mark and logo are registered trademarks of Bluetooth SIG, Inc.

This function enables you to play back audio sources from Bluetooth® audio devices. You need to register the Bluetooth® audio device in the system before using it.

NOTE

• The Bluetooth® audio function may not operate properly under the following conditions.

- The device is turned off.
- The battery of the device has run down.
- The device is not connected to the system.
- The device is behind the seat or in the glove box.
- A metal material is covering or touching the device.

• Depending on the type of device that is used, operation and sound volume may be different from normal use of those devices.

• The sound quality may degrade due to the influence of the device that is connected to the system or the circumstances of the Bluetooth network.

• When another Bluetooth® device is simultaneously connected, noise may be heard.

Media format

Bluetooth® audio devices cannot be connected if they are not compatible with the following Bluetooth® profiles.



• A2DP (Advanced Audio Distribution Profile)

• AVRCP (Audio/Video Remote Control Profile)

Setting Bluetooth® audio

NOTE

Bluetooth® audio can be set via the multi function display. For details, refer to “Bluetooth® audio setting” 3-92.

“MENU” button	
“TRACK” dial (type A audio)	
“TRACK” dial (type B audio)	

1. Select the “BT-A SETUP” menu by pressing the “MENU” button. For details, refer to “Other settings” 5-7.

2. Perform the following procedure by operating the “TRACK” dial while “BT-A” is displayed.

NOTE

You cannot set Bluetooth® audio while driving.

▼ Registering (pairing) device

NOTE

Only one device can be registered. If you want to register another device, delete the previously registered device and then perform the registering procedure. For details about deleting a device, refer to “Deleting device” 5-34.

1. Select the “PAIR AUDIO” menu.
 - If a device is already registered, “MEMORY FULL” will be displayed and the mode will change to the Bluetooth® audio setting mode.
2. After the passkey is shown on the display, input the passkey into the device.
 - If you input the correct passkey, “PAIRED” will be displayed and the registration procedure will be finished.
 - If you input an incorrect passkey, “FAILED” will be displayed, the registration procedure was not successful and the mode will change to the Bluetooth® audio setting mode.

NOTE

After the ignition switch is turned to the “LOCK”/“OFF” position, the registered device will not be automatically connected to the system even if the ignition switch is turned to the “ACC” or “ON” position.

▼ Selecting device

1. Select the “SELECT AUDIO” menu.
 - If no devices are registered, “EMPTY” will be displayed and the mode will change to the Bluetooth® audio setting mode.
2. Select the “CONFIRM” menu.
 - If the device is connected, “SELECTED” will be displayed and the selection procedure will be finished.
 - If the device cannot be connected, “FAILED” will be displayed and the selection procedure will not be successful.

▼ Setting passkey

1. Select the “SET PASSKEY” menu.
 - After the currently set passkey is displayed, a new passkey can be entered.
2. Input the new passkey by operating the “TRACK” dial.
3. Select the “CONFIRM” menu.

- The new passkey will be displayed, the passkey will be changed and the mode will change to the Bluetooth® audio setting mode.

▼ Deleting device

1. Select the “DELETE AUDIO” menu.
 - If no devices are registered, “EMPTY” will be displayed and the mode will change to the Bluetooth® audio setting mode.
2. Select the “CONFIRM” menu.
 - “DELETED” will be displayed and the mode will change to the Bluetooth® audio setting mode.

■ Bluetooth® audio operation

NOTE

Depending on the connected device, it may not activate as per the following items or not work smoothly.

▼ How to play back

NOTE

The following information will be displayed while playing Bluetooth® audio.

- Album name
- Artist name
- Song title

For details, refer to “Audio screen” 3-

54.

Perform any of the following procedures and select the “BT-A” mode.

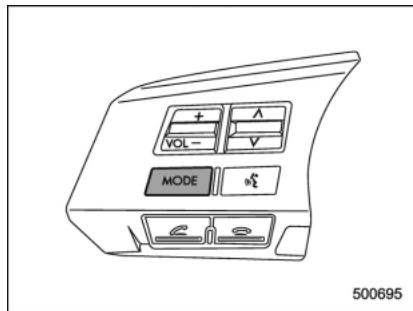

- Press the “MODE” button on the spoke of the steering wheel. For details, refer to “MODE button” 5-31.
- Press the “AUX/USB” button (type A audio).
- Press the “CD/AUX” button (type B audio).

▼ To select a track from its beginning

Select a track in the same way as for a CD. Refer to “To select a track from the beginning” 5-18.

▼ Repeating

Repeating is operated in the same way as for a CD. Refer to “Repeating” 5-19. Each time you briefly press the “RPT” button, the mode will change in the following sequence.

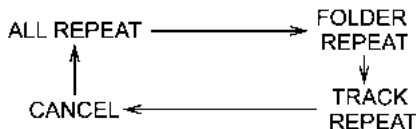

▼ Random playback

Random playback is operated in the same way as for a CD. Refer to “Random playback” 5-20. Each time you briefly press the “RDM” button, the mode will change in the following sequence.

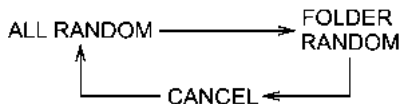

▼ Display selection

Select an item to be displayed using the same way as for a CD. Refer to “Display selection” 5-21. Each time you briefly press the **TEXT** button, the indication will change in the following sequence.

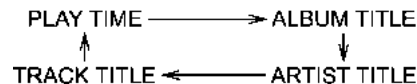

▼ Folder selection

Select a folder in the same way as for a CD. Refer to “Folder selection” 5-21.

Hands-free system

NOTE

- For models with the genuine SUBARU navigation system, refer to the Owner's Manual supplement for the navigation system.
- When selling your vehicle, make sure that you initialize the Hands-free system to prevent personal data from being improperly accessed.

The Hands-free system operates while the ignition switch is in the "ACC" or "ON" position.

You can use your cell phone without touching it by using the Hands-free system. To use the Hands-free system, connect a cell phone as follows.

When no cell phones are registered:

Register a cell phone to the in-vehicle equipment. For details, refer to "When no cell phones are registered" 5-47. After registering a phone, the phone will be automatically connected to the in-vehicle equipment.

When a cell phone is already registered:

The registered cell phone will be automatically connected to the in-vehicle equipment when the ignition switch is

turned to the "ACC" or "ON" position while carrying the cell phone.

When two cell phones or more are already registered:

If the system detects a cell phone in the passenger compartment which was previously connected to the in-vehicle equipment when the ignition switch was last turned to the "ACC" or "ON" position, the system connects the cell phone automatically to the in-vehicle equipment. You can select the phone to be connected to the in-vehicle equipment. For details, refer to "Selecting a cell phone" 5-47.

After connecting a cell phone, you can use the following functions.

Function	Page
Making a phone call	5-48
Taking/declining an incoming call	5-48
Registering phonebook data	5-49
Using and setting phonebook data	5-51
Deleting data	5-52

Even when no cell phones are connected, you may be able to set the following items.

Item	Page
Security setting	5-52
Phone setting	5-53
System setting	5-54

■ Safety precautions



WARNING

- For safety reasons, avoid operating a cell phone while driving.
- Do not make a phone call while driving. When you have an incoming call, stop the vehicle in a safe location before taking the incoming phone call. When you have to absolutely take a phone call, tell the caller "I'll call you back". And then call the caller back after stopping the vehicle in a safe location.



CAUTION

- Do not leave a cell phone in the vehicle. The temperature in the vehicle may become extremely high and cause a malfunction of the cell phone.

- When using a cell phone, be careful not to get it close to the in-vehicle equipment. Getting it too close to the in-vehicle equipment may result in deterioration in tone quality or a poor connecting condition.
- In the frequency band used by this equipment, along with industrial, scientific and medical equipment such as a microwave oven, radio stations (a license is required) to be used by the production line in the factory to identify movable bodies, specific small power radio stations (a license is not required) and amateur radio stations (a license is required) are being operated. (These three types of radio stations are hereinafter referred to as "other radio stations.") Before using this equipment, be sure to check to see if "other radio stations" are being operated in the vicinity. If there is detrimental radio interference from this equipment to "other radio stations," move the equipment to another location as soon as possible to avoid radio interference. The frequency band used

by this equipment is in the 2.4 GHz zone. The FH-SS modulation is employed as a modulation method. The expected inflicting interference distance is less than 33 ft (10 m). This equipment uses a full band and can avoid a band used by a movable body identification device.

■ Using the Hands-free system

▼ Turning on/off the Hands-free mode

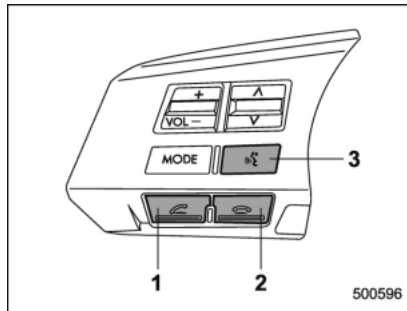



- 1) OFF hook switch
- 2) ON hook switch
- 3) Talk switch

To turn on the Hands-free mode, press the OFF hook switch . To turn off the

Hands-free mode, press the ON hook switch .

▼ Menu list of the Hands-free system (when not using the voice command system)

"TUNE/TRACK" dial:

Type A audio	
Type B audio	

1. Press the OFF hook switch  to turn on the Hands-free mode.
2. Turn the "TUNE/TRACK" dial to select a menu, and then press the dial to enter the selected menu.

5-38 Audio/Hands-free system

First menu	Second menu	Third menu	Details	Page
PHONE BOOK*	ADD ENTRY	BY VOICE	Adding a new number by voice	5-49
		BY PHONE	Adding a new number by cell phone	5-49
		MANUAL INPUT	Adding a new number by inputting manually	5-50
		CALL HISTORY	Adding a new number from the call history	5-50
		GO BACK		
	LIST NAMES	—	Showing the list of the names registered in the phonebook	5-51
	CHANGE NAME	—	Changing a name registered in the phonebook	5-51
	SET SPD DIAL	—	Registering a speed dial	5-51
	DELETE ENTRY	—	Deleting phonebook data	5-52
	DEL SPD DIAL	—	Deleting a registered speed dial	5-52
GO BACK	—			
REDIAL	DIAL	—	Redialing	5-48
	STORE	—	Adding a new number stored in the outgoing call history memory	5-50
	DELETE	—	Deleting a number stored in the outgoing call history memory	5-52
	GO BACK	—		
CALL BACK	DIAL	—	Dialing a number stored in the incoming call history memory	5-48
	STORE	—	Adding a new number stored in the incoming call history memory	5-50
	DELETE	—	Deleting a number stored in the incoming call history memory	5-52
	GO BACK	—		

*: If a cell phone is not registered, the menu described in the chart is not indicated.

First menu	Second menu	Third menu	Details	Page
SETUP	SECURITY	SET PIN	Setting a PIN code	5-52
		PHBK LOCK	Locking the phonebook	5-52
		PHBK UNLOCK	Unlocking the phonebook	5-53
		GO BACK		
	PHONE SETUP	PAIR PHONE	Registering a new cell phone	5-47
		SELECT PHONE	Selecting a cell phone to be used	5-47
		CHANGE NAME	Changing the registered name of the cell phone	5-53
		LIST PHONES	Showing the list of the registered cell phones	5-53
		SET PASSKEY	Changing the pass key	5-54
		DELETE	Deleting the registered cell phone	5-54
		GO BACK		
	SYSTEM SETUP	GUIDANCE VOL	Setting the volume of the voice guidance	5-54
		INITIALIZE	Initialization	5-54
		SEL LANGUAGE	Selecting the language (using Hands-free system)	5-54
		GO BACK		
	GO BACK	—		

▼ **Menu list of the Hands-free system
(when using voice command system)
(type B audio)**

NOTE

- Press the talk switch  and say "Help" to listen to the help guidance.
- For models with the multi function display, a list of enabled voice commands can be shown on the multi function display.

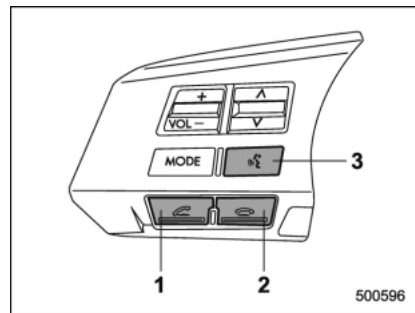

- 1) OFF hook switch
- 2) ON hook switch
- 3) Talk switch

To turn on the voice command system, press the talk switch  briefly. To turn off the voice command system, wait for 5 seconds without using the voice command system.

The commands available for the voice command system are listed in the following chart.

English:

First menu	Second menu	Third menu	Details	Page
Phone book*	Add entry	By voice	Adding a new number by voice	5-49
		By phone	Adding a new number by cell phone	5-49
		Call history	Adding a new number from call history	5-50
		Go back		
	List names		Showing the list of the names registered in the phonebook	5-51
	Change name		Changing a name registered in the phonebook	5-51
	Set speed dial		Registering a speed dial	5-51
	Delete entry		Deleting phonebook data	5-52
	Delete speed dial		Deleting a registered speed dial	5-52
	Go back			
Redial	Dial		Redialing	5-48
	Store		Adding a new number stored in the outgoing call history memory	5-50
	Delete		Deleting a number stored in the outgoing call history memory	5-52
	Go back			
Callback	Dial		Dialing a number stored in the incoming call history memory	5-48
	Store		Adding a new number stored in the incoming call history memory	5-50
	Delete		Deleting a number stored in the incoming call history memory	5-52
	Go back			

*: If a cell phone is not registered, you cannot use this command.

5-42 Audio/Hands-free system

First menu	Second menu	Third menu	Details	Page
Setup	Security	Set PIN	Setting a PIN code	5-52
		Phone book lock* ¹	Locking the phonebook	5-52
		Phone book unlock* ¹	Unlocking the phonebook	5-53
		Go back		
	Phone setup	Pair phone	Registering a new cell phone* ²	5-47
		Select phone	Selecting a cell phone to be used	5-47
		Change name	Changing the registered name of the cell phone	5-53
		List phones	Showing the list of the registered cell phones	5-53
		Set passkey	Changing the pass key	5-54
		Delete	Deleting the registered cell phone	5-54
Go back				
Dial by name			Making a phone call by saying a name	5-48
Dial by number			Making a phone call by saying a number	5-48
Outgoing* ³			Selecting an outgoing call history when adding a new number from the call history	5-50
Incoming* ³			Selecting an incoming call history when adding a new number from the call history	5-50

*1: If a PIN code is not registered, you cannot use these commands.

*2: Up to 5 cell phones can be registered.

*3: Select the "Phone book" menu then select the "Add entry" menu. Only after then selecting the "Call history" menu will these menus become available for use.

Français:

Premier menu	Deuxième menu	Troisième menu	Détails	Page
Registre*	Ajouter l'entrée	Vocalement	Ajout d'un nouveau numéro par la voix	5-49
		Par téléphone	Ajout d'un nouveau numéro par le téléphone cellulaire	5-49
		Historique d'appels	Ajout d'un nouveau numéro à partir de l'historique des appels	5-50
		Retourner		
	Lister les noms		Affichage de la liste des noms enregistrés dans le répertoire	5-51
	Modifier le nom		Changement du nom enregistré dans le répertoire	5-51
	Configurer composition abrégée		Enregistrement d'un appel rapide	5-51
	Supprimer l'entrée		Effacement de données du répertoire	5-52
	Supprimer composition abrégée		Effacement d'une composition rapide enregistrée	5-52
	Retourner			
Recomposer	Composer		Rappel du dernier numéro	5-48
	Enregistrer		Ajout d'un nouveau numéro enregistré dans la mémoire des historiques des appels sortants	5-50
	Supprimer		Suppression d'un numéro enregistré dans la mémoire des historiques des appels sortants	5-52
	Retourner			
Rappel	Composer		Appel du numéro enregistré dans la mémoire des historiques des appels entrants	5-48
	Enregistrer		Ajout d'un nouveau numéro enregistré dans la mémoire des historiques des appels entrants	5-50
	Supprimer		Suppression d'un numéro enregistré dans la mémoire des historiques des appels entrants	5-52
	Retourner			

*: Si un téléphone cellulaire n'est pas enregistré, vous ne pouvez pas utiliser cette commande.

Premier menu	Deuxième menu	Troisième menu	Détails	Page
Réglages	Sécurité	Configurer NIP	Réglage du code PIN	5-52
		Verrouiller le registre* ¹	Verrouillage du répertoire	5-52
		Déverrouiller le registre* ¹	Déverrouillage du répertoire	5-53
		Retourner		
	Réglages du téléphone	Jumeler le téléphone	Enregistrement d'un nouveau téléphone cellulaire* ²	5-47
		Sélectionner le téléphone	Sélection du téléphone cellulaire à utiliser	5-47
		Modifier le nom	Changement du nom enregistré du téléphone cellulaire	5-53
		Lister les téléphones	Affichage de la liste des téléphones cellulaires enregistrés	5-53
		Configurer le passe-partout	Changement du mot de passe	5-54
		Supprimer	Effacement d'un téléphone cellulaire enregistré	5-54
		Retourner		
Composer par nom			Passer un appel en dictant le nom	5-48
Composer par numéro			Passer un appel en dictant le numéro	5-48
Sortant* ³			Sélectionner un historique d'appels sortants lors de l'ajout d'un nouveau numéro à partir de l'historique des appels	5-50
Entrant* ³			Sélectionner un historique d'appels entrants lors de l'ajout d'un nouveau numéro à partir de l'historique des appels	5-50

*1: Si un code PIN n'est pas enregistré, vous ne pouvez pas utiliser ces commandes.

*2: Vous pouvez enregistrer jusqu'à 5 téléphones.

*3: Vous ne pouvez sélectionner ces menus qu'après avoir sélectionné, dans l'ordre, les menus "Registre", "Ajouter l'entrée" puis "Historique d'appels".

The other commands available for the voice command system are listed in the following chart.

	Command		Details
	English	Français	
1	0 (zero, oh)	0 (zéro)	—
2	1 (one)	1 (un)	—
3	2 (two)	2 (deux)	—
4	3 (three)	3 (trois)	—
5	4 (four)	4 (quatre)	—
6	5 (five)	5 (cinq)	—
7	6 (six)	6 (six)	—
8	7 (seven)	7 (sept)	—
9	8 (eight)	8 (huit)	—
10	9 (nine)	9 (neuf)	—
11	* (star)	* (étoile)	—
12	# (pound)	# (carré, dièse)	—
13	+ (plus)	+ (plus)	—
14	cancel	annuler	Turning off the Hands-free system
15	help	aide	Listening to the help guidance
16	repeat	répéter	Repeat the help guidance that you listened to before speaking the “repeat” command.
17	previous	précédent	
18	confirm	confirmer	
19	PHONE BOOK add entry	ajouter l'entrée dans le registre	Adding a new number





5-46 *Audio/Hands-free system*

	Command		Details
	English	Français	
20	PHONE BOOK change name	modifier le nom dans le registre	Changing a name registered in the phonebook
21	PHONE BOOK delete entry	supprimer l'entrée du registre	Deleting phonebook data
22	PHONE BOOK list names	lister les noms du registre	Showing the list of the names registered in the phonebook
23	PHONE BOOK set speed dial	configurer composition abrégée pour le registre	Registering a speed dial
24	PHONE BOOK delete speed dial	supprimer composition abrégée pour le registre	Deleting a registered speed dial

▼ Preparation for using the Hands-free system

▽ When no cell phones are registered

Before using the Hands-free system, it is necessary to register a cell phone in the system. Perform the following procedure to register a cell phone.

1. Press the OFF hook switch .
2. Select "ENGLISH"/"FRANÇAIS" by operating the "TUNE/TRACK" dial.
3. Press the "TUNE/TRACK" dial when the language of your choice is displayed.
 - "WELCOME!" will be displayed.
 - Voice prompts will now begin to help guide you through the pairing process.
4. Press the "TUNE/TRACK" dial or the talk switch  to begin the pairing process.
5. Perform either of the following procedures.
 - Select the "RECORD NAME" menu by using the "TUNE/TRACK" dial or
 - Press the talk switch  located on the steering wheel.
6. Say the name (voice tag) to be registered.
7. Press the talk switch  and say the word "Confirm" to confirm the recorded

name.

- Go to your phone's setting menu and access the Bluetooth device menu.
 - Scan for available Bluetooth devices.
 - "CAR M_MEDIA" should be displayed on your phone as an available device. Select this device.
 - After "CAR M_MEDIA" is selected, a pass key will be displayed.
8. Input the displayed pass key from the radio into the cell phone while "PKY: ****" is displayed on the radio.
 - If you input the correct pass key, "PAIRED" will be displayed and the registration procedure will be finished.
 - If you input an incorrect pass key, "FAILED" will be displayed and the registration procedure will not be successful.

▽ Registering a cell phone

To register a cell phone to the in-vehicle equipment, perform the following procedure.

1. Select the "SETUP" menu.
2. Select the "PHONE SETUP" menu.
3. Select the "PAIR PHONE" menu.
4. Perform either of the following procedures.

- Select the "RECORD NAME" menu.

- Press the talk switch .

5. Say the name (voice tag) to be registered.
6. Select the "CONFIRM" menu.
 - After "CAR M_MEDIA" is displayed, a pass key will be displayed.
7. Input the displayed pass key into the cell phone while "PKY: ****" is displayed.
 - If you input the correct pass key, "PAIRED" will be displayed and the registration procedure will be finished.
 - If you input an incorrect pass key, "FAILED" will be displayed and the registration procedure will not be successful.

▽ Selecting a cell phone

To select the registered cell phone for connecting to the in-vehicle equipment, perform the following procedure.



1. Select the "SETUP" menu.
2. Select the "PHONE SETUP" menu.
3. Select the "SELECT PHONE" menu.
 - If no cell phones are registered, "EMPTY" will be displayed and the mode will change to the "PHONE SETUP" mode.
4. Select the cell phone by performing

either of the following procedures.



- Operate the “TUNE/TRACK” dial.
 - Press the talk switch  and say the voice tag.
5. Select the “CONFIRM” menu.
- “SELECTED” will be displayed, the selected cell phone will be connected to the in-vehicle equipment and the mode will change to the “PHONE SETUP” mode.
 - If the selected cell phone cannot be connected, “FAILED” will be displayed and the mode will change to the “PHONE SETUP” mode.

▼ Making a phone call

▽ Making a phone call by saying name

1. Select the top menu (phone menu).
2. Press the talk switch .
3. Say “DIAL BY NAME”.
4. Press the talk switch  again.
5. Say the preferred name (voice tag) to be called.
 - Then the called name (voice tag) or the corresponding phone number will be displayed.
6. Select the “DIAL” menu or press the OFF hook switch .

▽ Making a phone call by saying number

1. Select the top menu (phone menu).
2. Press the talk switch .
3. Say “DIAL BY NUMBER”.
4. Press the talk switch  again.
5. Say the preferred phone number to be called.
6. Select the “DIAL” menu or press the OFF hook switch .

▽ Making a phone call from speed dial

It is possible to select a phone number from speed dial registered with the in-vehicle equipment to make a phone call.

1. Press the preset button (from 1 to 6) to which the preferred number is registered.
2. Press the OFF hook switch .

NOTE

When a preset button for which numbers are not registered is pressed, an error message will be indicated on the audio screen.

▽ Redial

1. Select the “REDIAL” menu.

2. Select the preferred number by operating the “TUNE/TRACK” dial.
3. Select the “DIAL” menu or press the OFF hook switch .



▽ Callback

1. Select the “CALL BACK” menu.
2. Select the preferred number by operating the “TUNE/TRACK” dial.
3. Select the “DIAL” menu or press the OFF hook switch .

▽ Making a phone call from list name

It is possible to select a phone number from the list name registered with the in-vehicle equipment to make a phone call. For details, refer to “List names function”  5-51.

▽ Top redial

1. Press the OFF hook switch  and load the outgoing call history.
2. Select the “DIAL” menu or press the OFF hook switch .

▼ Taking a phone call and declining an incoming call

To take a phone call: Press the OFF hook switch .

To put an incoming call on hold (only if the cell phone has this function): Press the ON hook switch  briefly.

To decline an incoming call (only if the cell phone has this function): Press and hold the ON hook switch .

▼ Ending a call

Press the ON hook switch .

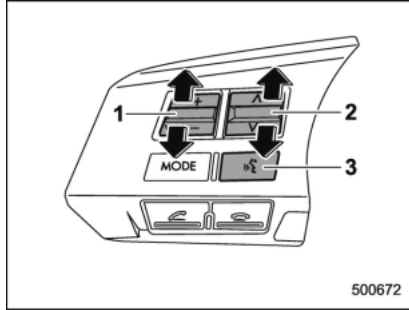

▼ Volume control



- 1) Volume control switch
- 2) Speech volume control switch
- 3) Talk switch

Press the volume control switch to the “+” side to increase the phone call volume, voice volume and voice guidance volume. Press the switch to the “-” side to decrease the volume.

Press the speech volume control switch to the “^” side to increase the speech volume. Press the switch to the “v” side to decrease the volume.

During a call, press the talk switch  to turn the microphone off. Press the talk switch  once again to turn the microphone on.

▽ Adjustable level of each volume

Volume	Range	Initial setting
Phone call	0 to 14	7
Voice	0 to 14	7
Voice guidance	0 to 6	3

▼ Registering phonebook data

NOTE

The maximum number of phonebook entries that can be registered in the phonebook is 50.

▽ Registering by voice

1. Select the “PHONE BOOK” menu.
2. Select the “ADD ENTRY” menu.
3. Select the “BY VOICE” menu.
4. Press the talk switch .
5. Say the phone number to be registered.
6. Select the “CONFIRM” menu.

7. Perform either of the following procedures.

- Select the “RECORD NAME” menu by operating the “TUNE/TRACK” dial.
- Press the talk switch .

8. Say the name (voice tag) to be registered.

9. Select the “CONFIRM” menu.

- Then “STORED” will be displayed and the mode will change to the registering speed dial mode. Refer to “Registering speed dial”  5-51.

▽ Registering by phone

1. Select the “PHONE BOOK” menu.
2. Select the “ADD ENTRY” menu.
3. Select the “BY PHONE” menu.
4. Select the “CONFIRM” menu.
 - Then “TRANSFER” will be displayed.
5. Transfer the data from the cell phone. For details about transferring the data, refer to the instruction manual of the cell phone.
6. Select the “CONFIRM” menu.
7. Perform either of the following procedures.
 - Select the “RECORD NAME” menu by operating the “TUNE/TRACK” dial.
 - Press the talk switch .

- Say the name (voice tag) to be registered.
- Select the "CONFIRM" menu.
 - Then "STORED" will be displayed and the mode will change to the registering speed dial mode. Refer to "Registering speed dial" 5-51.

▽ Registering by inputting manually

- Select the "PHONE BOOK" menu.
- Select the "ADD ENTRY" menu.
- Select the "MANUAL INPUT" menu by operating the "TUNE/TRACK" dial.
- Input the phone number to be registered.
- Perform either of the following procedures.
 - Select the "RECORD NAME" menu by operating the "TUNE/TRACK" dial.
 - Press the talk switch .
- Say the name (voice tag) to be registered.
- Select the "CONFIRM" menu.
 - Then "STORED" will be displayed and the mode will change to the registering speed dial mode. Refer to "Registering speed dial" 5-51.

NOTE

While inputting the phone numbers, if "GO BACK" is chosen using the "TUNE/TRACK" dial, the character that was input last will be deleted.

▽ Registering from call history

- Select the "PHONE BOOK" menu.
- Select the "ADD ENTRY" menu.
- Select the "CALL HISTORY" menu.
- Select the "OUTGOING" or "INCOMING" menu.
- Select the phone number by operating the "TUNE/TRACK" dial.
- Perform either of the following procedures.
 - Select the "RECORD NAME" menu by operating the "TUNE/TRACK" dial.
 - Press the talk switch .
- Say the name (voice tag) to be registered.
- Select the "CONFIRM" menu.
 - Then "STORED" will be displayed and the mode will change to the registering speed dial mode. Refer to "Registering speed dial" 5-51.

▽ Registering from redial

- Select the "REDIAL" menu.
- Select the phone number by operating

the "TUNE/TRACK" dial.

- Select the "STORE" menu.
- Select the "CONFIRM" menu.
- Perform either of the following procedures.
 - Select the "RECORD NAME" menu by operating the "TUNE/TRACK" dial.
 - Press the talk switch .
- Say the name (voice tag) to be registered.
- Select the "CONFIRM" menu.
 - Then "STORED" will be displayed and the mode will change to the registering speed dial mode. Refer to "Registering speed dial" 5-51.

▽ Registering from call back

- Select the "CALL BACK" menu.
- Select the phone number by operating the "TUNE/TRACK" dial.
- Select the "STORE" menu.
- Select the "CONFIRM" menu.
- Perform either of the following procedures.
 - Select the "RECORD NAME" menu by operating the "TUNE/TRACK" dial.
 - Press the talk switch .
- Say the name (voice tag) to be registered.
- Select the "CONFIRM" menu.

– Then “STORED” will be displayed and the mode will change to the registering speed dial mode. Refer to “Registering speed dial” 5-51.

▽ Registering speed dial

1. After registering phonebook data, select the “SPEED DIAL” menu.
2. Press the preset button (from 1 to 6) to which you want to register the phone number.

NOTE

If the number to be used is already registered in speed dial, “OVERWRITE?” will be displayed.

▼ Using and setting phonebook data

▽ List names function

The voice tags registered in the phonebook are spoken by using the list names function. To use the list names function, perform the following procedure.

1. Select the “PHONE BOOK” menu.
2. Select the “LIST NAMES” menu.
3. Select the registered data by performing either of the following procedures.
 - Press the talk switch .
 - Operate the “TUNE/TRACK” dial.
4. After “SELECTED” is displayed, you

can select the following menus.

- “DIAL” to make a phone call
- “CHANGE NAME” to change the name (voice tag)
- “SET SPD DIAL”/“SET SPEED DIAL” to set the speed dial
- “DELETE ENTRY” to delete the name (voice tag) from the phonebook
- “GO BACK” to go back to the menu mode

NOTE

- After “LIST NAMES” is selected, if the OFF hook switch  is pushed, the selected number will be called.
- After “LIST NAMES” is selected, if no operation is performed, the memories will be displayed and voice tags will be spoken. After all memories/voice tags are displayed/spoken, “END OF LIST” will be displayed and the mode will change to the “PHONE BOOK” menu mode.

▽ Changing voice tag

1. Select the “PHONE BOOK” menu.
2. Select the “CHANGE NAME” menu.
3. Select the phone number by performing either of the following procedures.
 - Operate the “TUNE/TRACK” dial.
 - Press the talk switch  and say

the voice tag.

4. Select the “CONFIRM” menu (only after saying the voice tag).
 - Then the selected phone number/name will be displayed.
5. Perform either of the following procedures.
 - Select the “RECORD NAME” menu by operating the “TUNE/TRACK” dial.
 - Press the talk switch .
6. Say the new voice tag.
7. Select the “CONFIRM” menu.
 - Then “CHANGED” will be displayed.

▽ Set speed dial

1. Select the “PHONE BOOK” menu.
2. Select the “SET SPD DIAL”/“SET SPEED DIAL” menu.
3. Select the phone number by performing either of the following procedures.
 - Operate the “TUNE/TRACK” dial.
 - Press the talk switch  and say the voice tag.
4. Select the “CONFIRM” menu (only after saying the voice tag).
5. Press the preset button (from 1 to 6) to which you want to register the phone number.



NOTE

If the number to be used is already registered in speed dial, "OVERWRITE?" will be displayed.

▼ Deleting data**▽ Deleting the phonebook data**

1. Select the "PHONE BOOK" menu.
2. Select the "DELETE ENTRY" menu.
3. Select the phone number by performing either of the following procedures.
 - Operate the "TUNE/TRACK" dial.
 - Press the talk switch  and say the voice tag.
4. Select the "CONFIRM" menu.
 - Then "DELETED" will be displayed and the selected phonebook data will be deleted.

▽ Deleting the speed dial

1. Select the "PHONE BOOK" menu.
2. Select the "DEL SPD DIAL"/"DELETE SPEED DIAL" menu.
3. Press the preset button (from  to ) to which you want to delete the speed dial.
4. Select the "CONFIRM" menu.
 - Then "DELETED" will be displayed and the selected speed dial will be deleted.

▽ Deleting the redial data

1. Select the "REDIAL" menu.
2. Select the phone number by operating the "TUNE/TRACK" dial.
3. Select the "DELETE" menu.
4. Select the "CONFIRM" menu.
 - Then "DELETED" will be displayed and the selected redial data will be deleted.

▽ Deleting the callback data



1. Select the "CALLBACK" menu.
2. Select the phone number by operating the "TUNE/TRACK" dial.
3. Select the "DELETE" menu.
4. Select the "CONFIRM" menu.
 - Then "DELETED" will be displayed and the selected callback data will be deleted.

■ Bluetooth® settings**▼ Security setting**

1. Select the "SETUP" menu.
2. Select the "SECURITY" menu.
3. Perform the following procedures.

▽ Setting PIN code

The PIN code is a 4-digit number and is used when locking the phonebook.

1. Select the "SET PIN" menu.
 - Then "CURRENT PIN?" will be displayed.
2. Input the current PIN code by performing either of the following procedures.
 - Operate the "TUNE/TRACK" dial.
 - Press the talk switch  and say the number.
3. Select the "CONFIRM" menu.
4. Input the new PIN code by performing either of the following procedures.
 - Operate the "TUNE/TRACK" dial.
 - Press the talk switch  and say the number.
5. Select the "CONFIRM" menu.

▽ Locking the phonebook**CAUTION**

After locking the phonebook, you cannot unlock the phonebook without inputting the PIN code. Do not forget the PIN code after locking the phonebook.

1. Select the "PHBK LOCK"/"PHONEBOOK LOCK" menu.
 - Then "CURRENT PIN?" will be displayed.
2. Input the PIN code by performing

either of the following procedures.

- Operate the “TUNE/TRACK” dial.
 - Press the talk switch  and say the number.
3. Select the “CONFIRM” menu.
 - If the inputted PIN code is correct, “LOCKED” will be displayed and the phonebook will be locked.

NOTE

While the phonebook is locked, if the operation restricted menu is selected, “PHBK LOCK” will be displayed.

▽ Unlocking the phonebook

NOTE

If you have forgotten your PIN code and/or are somehow unable to unlock the phonebook, the phonebook lock can be released by initializing the registered data and re-setting the PIN code. However, initializing the data will cause all data registered in the hands-free system, such as the registration devices and phonebook data, to be erased. For initialization, refer to “Initializing the registered data” 5-54.

1. Select the “PHBK UNLOCK”/“PHONEBOOK UNLOCK” menu.
 - Then “CURRENT PIN?” will be

displayed.

NOTE

If the phonebook is not locked, “UNLOCK” will be displayed and the mode will change to the security mode.

2. Input the PIN code by performing either of the following procedures.
 - Operate the “TUNE/TRACK” dial.
 - Press the talk switch  and say the number.
3. Select the “CONFIRM” menu.
 - If the inputted PIN code is correct, “UNLOCKED” will be displayed and the phonebook will be unlocked.

▼ Phone setup

1. Select the “SETUP” menu.
2. Select the “PHONE SETUP” menu.
3. Perform the following procedures.

▽ Setting pair phone

Refer to “Registering a cell phone” 5-47.



▽ Selecting phone

Refer to “Selecting a cell phone” 5-47.

▽ Changing the voice tag of the cell phone

1. Select the “CHANGE NAME” menu.
 - If no cell phones are registered,

“EMPTY” will be displayed and the mode will change to the “PHONE SETUP” mode.

2. Select the cell phone by performing either of the following procedures.
 - Operate the “TUNE/TRACK” dial.
 - Press the talk switch  and say the voice tag.
3. Perform either of the following procedures.
 - Select the “RECORD NAME” menu by operating the “TUNE/TRACK” dial.
 - Press the talk switch .
4. Say the new voice tag to be registered.
5. Select the “CONFIRM” menu.
 - “CHANGED” will be displayed and the mode will change to the “PHONE SETUP” mode.

▽ List phones function

The cell phone voice tags saved in the cell phone list are spoken by using the list phones function.

1. Select the “LIST PHONES” menu.
 - If no cell phones are registered, “EMPTY” will be displayed and the mode will change to the “PHONE SETUP” mode.
2. Registered cell phones will be displayed in the saved order. While displayed, if the “TUNE/TRACK” dial is

– **CONTINUED** –

turned, the next registered cell phone will be displayed. Press the ON hook button  to close the Hands-free menu.

3. Select a cell phone by performing either of the following procedures.

- Operate the “TUNE/TRACK” dial.
- Press the talk switch .

4. After “SELECTED” is displayed, you can select the following menus.

- “SELECT PHONE” to connect the selected cell phone
- “CHANGE NAME” to change the voice tag
- “DELETE” to delete the selected cell phone from the list
- “GO BACK” to go back to the “PHONE SETUP” mode

▽ Setting passkey

1. Select the “SET PASSKEY” menu.
 - After the currently set passkey is displayed, a new passkey can be entered.
2. Input the new passkey by performing either of the following procedures.
 - Operate the “TUNE/TRACK” dial.
 - Press the talk switch  and say the passkey.
3. Select the “CONFIRM” menu.
 - The new passkey will be displayed,

the passkey will be changed and the mode will change to the “PHONE SETUP” mode.

▽ Deleting registered cell phone from the list

1. Select the “DELETE” menu.
2. Select a cell phone to be deleted by performing either of the following procedures.
 - Operate the “TUNE/TRACK” dial.
 - Press the talk switch  and say the voice tag.
3. Select the “CONFIRM” menu.
 - “DELETED” will be displayed, the data will be deleted and the mode will change to the “PHONE SETUP” mode.

▼ System setup

1. Select the “SETUP” menu.
2. Select the “SYSTEM SETUP” menu.
3. Perform the following procedures.

▽ Setting guidance volume

To set the guidance volume, perform the following procedure.

1. Select the “GUIDANCE VOL” menu by operating the “TUNE/TRACK” dial.
2. Set the guidance volume by operating

the “TUNE/TRACK” dial.

▽ Initializing the registered data

To initialize the registered data, perform the following procedure.

1. Select the “INITIALIZE” menu by operating the “TUNE/TRACK” dial.
2. Select the “CONFIRM” menu by operating the “TUNE/TRACK” dial.
 - First “PLEASE WAIT”, then “INITIALIZED” will be displayed. The registered data will be initialized and the mode will change to the last mode.

▽ Selecting language

To select the language, perform the following procedure.

1. Select the “SEL LANGUAGE” menu by operating the “TUNE/TRACK” dial.
2. Select the preferred language by operating the “TUNE/TRACK” dial.

■ Tips for the Hands-free system

▼ Bluetooth®

It is possible to connect a cell phone to the in-vehicle equipment through the **Bluetooth®** format (wireless) to make a phone call from the in-vehicle equipment or take

an incoming phone call.

Since the **Bluetooth**[®] format is wireless, a connection between the in-vehicle equipment and the cell phone can be made without placing them in close proximity of each other. The cell phone can be used with it left in the breast pocket or bag.

NOTE

- The Hands-free system may not operate properly under the following conditions.
 - The cell phone is turned off.
 - The cell phone is not in the phone call area.
 - The battery of the cell phone has run down.
 - The cell phone is not connected to the Hands-free system.
 - The cell phone is behind the seat or in the glove box.
 - A metal material covers or touches the cell phone.
- Depending on the type of cell phone that is used, the screen on the cell phone may remain illuminated while the ignition switch is in the "ON" position. If this occurs, turn the illumination off by adjusting the cell phone settings.
- Depending on the setting of the cell phone, the dial lock function may be

activated after making a call. Deactivate the automatic dial lock function of the cell phone before using the Hands-free system.

- Depending on the type of cell phone that is used, operation and the sound volume may be different from those of cell phones currently used.
- When the ignition switch is turned to the "LOCK"/"OFF" position during a call, the call may be disconnected or continued on the cell phone depending on the type of cell phone that is used. Note that operation of the cell phone may be necessary if the call is continued on the cell phone.
- Do not speak at the same time as the other party during a call. If you and the other party speak at the same time, it may be difficult for the other party to hear your voice and vice versa. This is normal.
- The receiver sound volume should be set as low as possible. Otherwise, the party you are calling may notice an undesirable echo sound.
- Speak clearly and loudly.
- It may be difficult for the other party to hear your voice under the following conditions.
 - Driving on a rough road
 - Driving at a high speed

- Driving with a window open
- When air from the ventilator blows directly towards the microphone
- When the sound coming from the ventilator is loud
- When the cell phone is too close to the microphone
- The sound quality may degrade due to the influence of the cell phone that is connected to the system or the circumstances of the Bluetooth network.
- When another Bluetooth[®] device is simultaneously connected, noise may be heard in the voice coming from the hands-free phone.
- ▼ Corresponding profiles for the cell phone
 - HFP (Hands Free Profile): Ver. 1.0
 - OPP (Object Push Profile): Ver. 1.1

■ Certification for the Hands-free system



CAUTION

FCC CAUTION

Changes or modifications not expressly approved by the party responsible for compliance could void the user's authority to operate the equipment.

NOTE

This device complies with Part 15 of FCC Rules and Industry Canada licence-exempt RSS standard(s). Operation is subject to the following two conditions: (1) this device may not cause interference, and (2) this device must accept any interference, including interference that may cause undesired operation of this device.

Le présent appareil est conforme aux la partie 15 des règles de la FCC et CNR d'Industrie Canada applicables aux appareils radio exempts de licence. L'exploitation est autorisée aux deux conditions suivantes: (1) l'appareil ne doit pas produire de brouillage, et (2) l'utilisateur de l'appareil doit accepter tout brouillage radioélectrique subi,

même si le brouillage est susceptible d'en compromettre le fonctionnement.

NOTE

This equipment complies with FCC/IC radiation exposure limits set forth for an uncontrolled environment and meets the FCC radio frequency (RF) Exposure Guidelines in Supplement C to OET65 and RSS-102 of the IC radio frequency (RF) Exposure rules. This equipment has very low levels of RF energy that it deemed to comply without maximum permissive exposure evaluation (MPE). But it is desirable that it should be installed and operated keeping the radiator at least 20cm or more away from person's body (excluding extremities: hands, wrists, feet and ankles).

Cet équipement est conforme aux limites d'exposition aux rayonnements énoncées pour un environnement non contrôlé et respecte les règles des radioélectriques (RF) de la FCC lignes directrices d'exposition dans le Supplément C à OET65 et d'exposition aux fréquences radioélectriques (RF) CNR-102 de l'IC. Cet équipement émet une énergie RF très faible qui est considérée conforme sans évaluation de l'exposition maximale autorisée. Cependant,

cet équipement doit être installé et utilisé en gardant une distance de 20 cm ou plus entre le dispositif rayonnant et le corps (à l'exception des extrémités: mains, poignets, pieds et chevilles).

This transmitter must not be co-located or operated in conjunction with any other antenna or transmitter.

▼ Mexico models

Módulo Bluetooth instalado en el interior de la radio

COFETEL RCPCLPF13-0984

Clarion

PF-3633

500720

La operación de este equipo está sujeta a las siguientes dos condiciones:

- (1) es posible que este equipo o dispositivo no cause interferencia perjudicial y
- (2) este equipo o dispositivo debe aceptar cualquier interferencia, incluyendo

la que pueda causar su operación no deseada.

500721

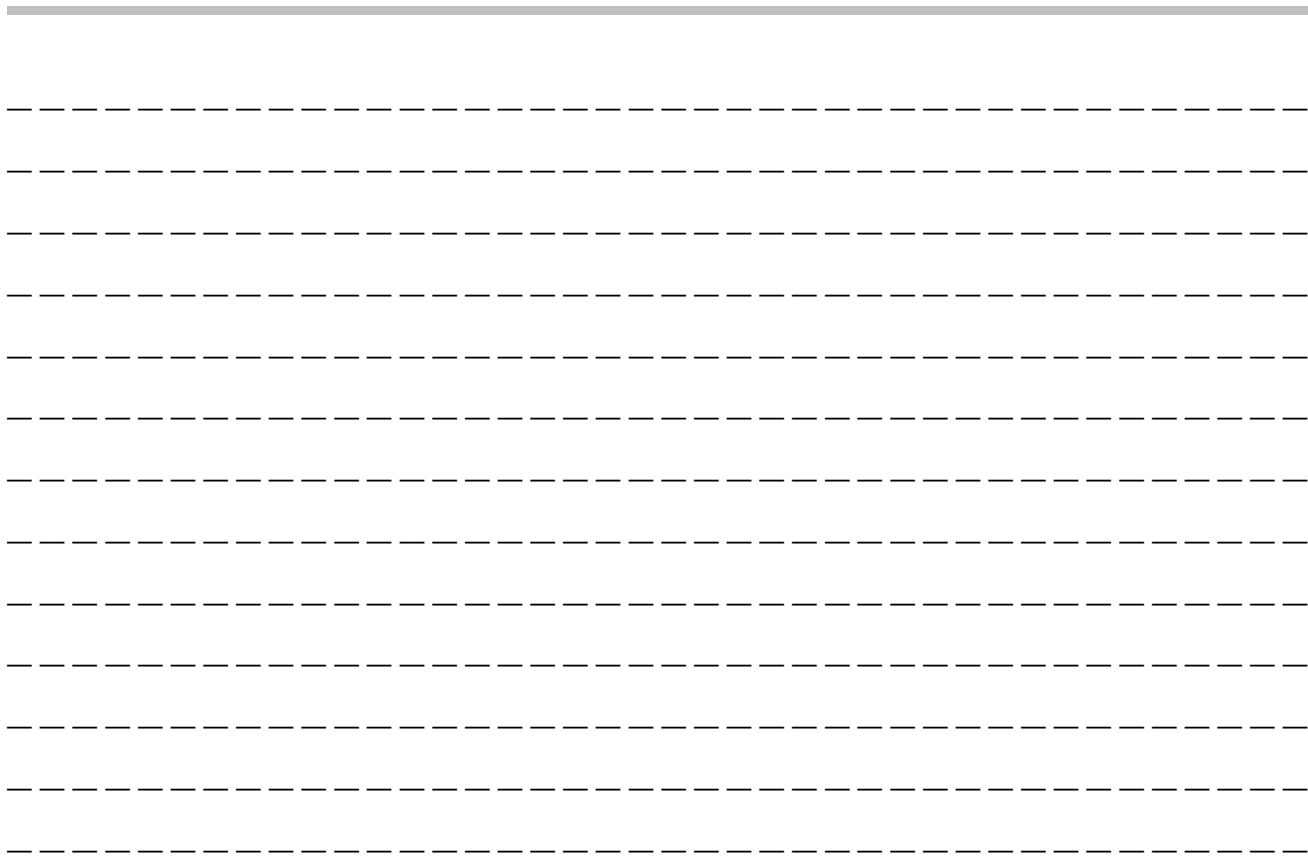

Interior lights	6-2	Bottle holders	6-7
Dome light	6-2	Accessory power outlets	6-7
Map lights	6-2	Use with a cigarette lighter (if equipped).....	6-8
OFF delay timer	6-3	Ashtray (if equipped)	6-9
Sun visors	6-3	Floor mat (if equipped)	6-10
Vanity mirror with light	6-4	Coat hook	6-11
Storage compartment	6-4	Under-floor storage compartment	6-11
Glove box	6-4	Rear view camera (if equipped)	6-12
Center console.....	6-5	How to use the rear view camera	6-13
Cup holders	6-5	Viewing range on the screen.....	6-14
Front passenger's cup holder	6-5	Help line.....	6-15
Rear passenger's cup holder	6-6		

Interior lights



CAUTION

When leaving your vehicle, make sure the lights are turned off to avoid battery discharge.

■ Dome light

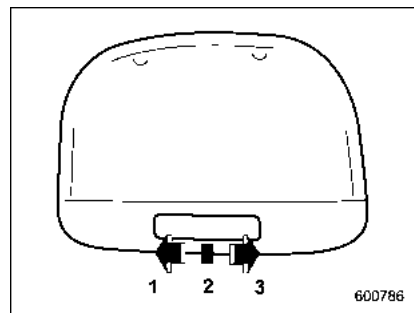

- 1) ON
- 2) DOOR
- 3) OFF

The dome light switch has the following three positions.

ON: The light remains on continuously.

OFF: The light remains off.

DOOR: The dome light illuminates automatically in the following cases.

- Any of the doors is opened.
- The doors are unlocked using the keyless access function (if equipped). Refer to “Locking and unlocking with “keyless access” entry function” 2-11.
- The doors are unlocked using the remote keyless entry system. Refer to “Remote keyless entry system” 2-17.
- The ignition switch is turned from the “ACC” position to the “LOCK”/“OFF” position.

■ Map lights

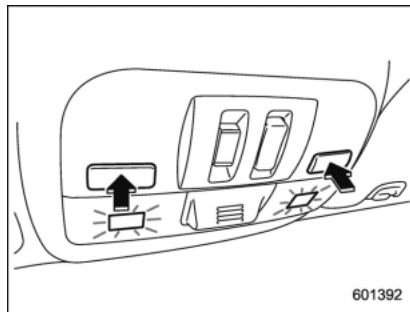

Type A

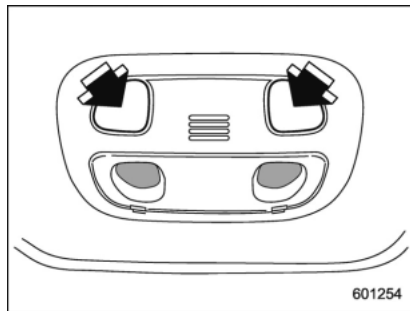

Type B

To turn on the map light, push the switch. To turn it off, push the switch again.

When leaving the vehicle, make sure the lights are turned off to avoid battery discharge.

▼ Automatic illumination (type A map lights)

The map lights illuminate automatically in the following cases.

- Any of the doors is opened.
- The doors are unlocked using the keyless access function (if equipped). Refer to "Locking and unlocking with "keyless access" entry function" 2-11.
- The doors are unlocked using the remote keyless entry transmitter.
- The ignition switch is turned from the "ACC" position to the "LOCK"/"OFF" position.

■ OFF delay timer

The following lights have an automatic illumination function.

- dome light (when the dome light switch is in the "DOOR" position)
- map light (type A)

After being illuminated automatically, these lights remain on for several seconds and then gradually turn off after all doors are closed.

While the lights are illuminated, if any of the following operations are performed, the lights turn off immediately.

- The ignition switch is turned from the "LOCK"/"OFF" position to the "ACC" or "ON" position.
- All doors are locked using the keyless access function (if equipped).
- All doors are locked using the remote keyless entry system.

The setting for the period of time in which the lights remain on (OFF delay timer) can be changed by a SUBARU dealer. Contact your SUBARU dealer for details. Also, the setting can be changed by operating the multi function display. For details, refer to "Interior light off delay timer setting" 3-86.

Sun visors

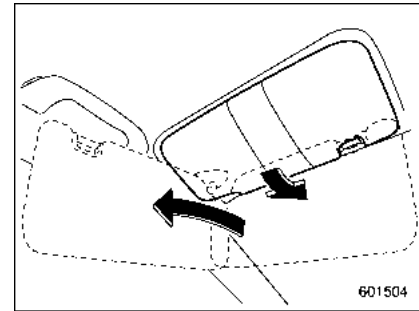

To block out glare, swing down the visors. To use the sun visor at a side window, swing it down and move it sideways.

■ Vanity mirror with light



CAUTION

Keep the vanity mirror cover closed while the vehicle is being driven to avoid being temporarily blinded by the glare of bright light.

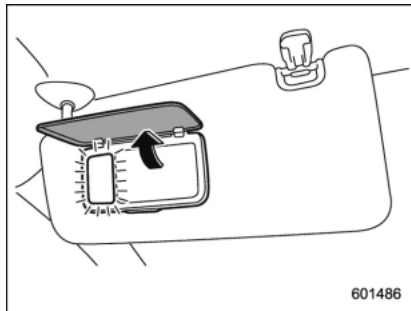

To use the vanity mirror, swing down the sun visor and open the vanity mirror cover. The light beside the vanity mirror illuminates when the mirror cover is opened.

NOTE

Use of the vanity mirror light for a long period of time while the engine is not running can cause battery discharge.

Storage compartment



CAUTION

- Always keep the storage compartment closed while driving to reduce the risk of injury in the event of a sudden stop or an accident.
- Do not store spray cans, containers with flammable or corrosive liquids or any other dangerous items in the storage compartment.

■ Glove box

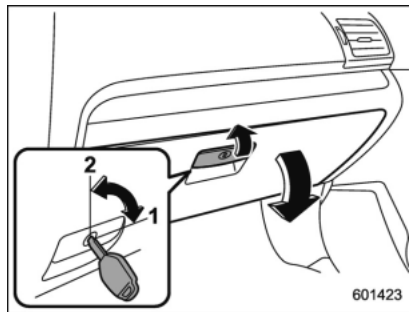

- 1) Lock
- 2) Unlock

To open the glove box, pull the handle. To close it, push the lid firmly upward. When the light control switch is in the "O" or "OFF" position (or when the headlight indicator light illuminates in the combination meter if the light control switch is in the "AUTO" position), the glove box light will illuminate if the lid is opened.

To lock the glove box, insert the key and turn it clockwise. To unlock the glove box, insert the key and turn it counterclockwise.

■ Center console

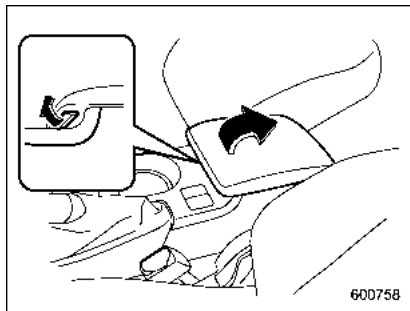

To open the lid, pull up the lock release.

Cup holders

▲ CAUTION

Take care to avoid spills. Beverages, if hot, might burn you and/or your passengers. Spilled beverages may also damage upholstery, carpets or audio equipment.

■ Front passenger's cup holder

▲ CAUTION

Do not pick up a cup from the cup holder or put a cup in the holder while you are driving, as this may distract you and lead to an accident.

▼ Except STI

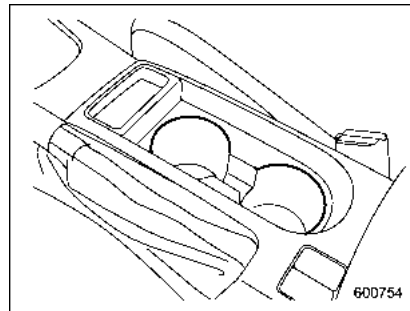

A dual cup holder is built into the center console, beside the parking brake lever.

▼ STI

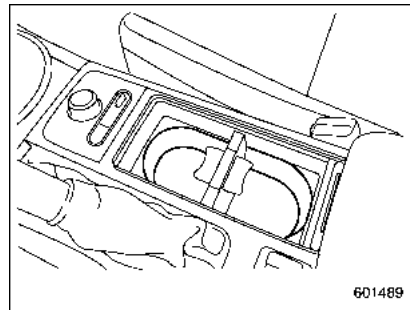

The dual cup holder is built into the center

console near the parking brake lever.

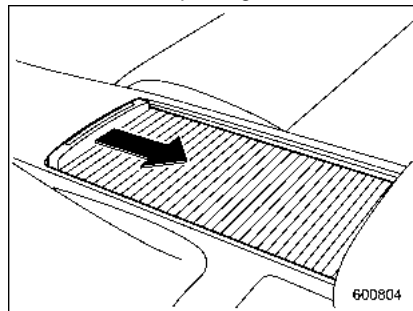

To access the cup holder, pull the lid toward the rear.

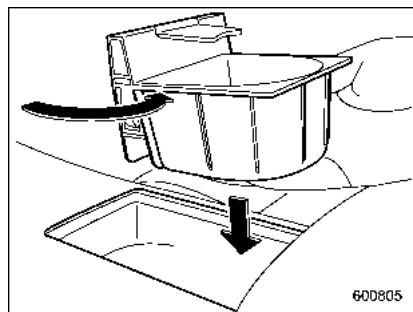

The divider in the cup holder can be pulled out and inserted in a different position (further toward the front or rear) to enable

cups of different sizes to be held.

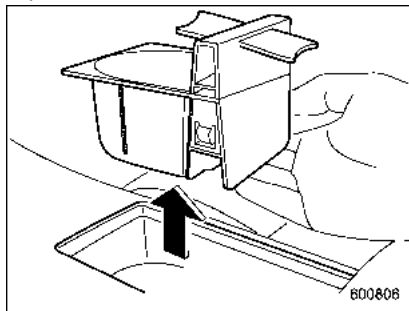

NOTE

With the divider taken out, the cup holder can be used as a storage box.

■ Rear passenger's cup holder

⚠ CAUTION

When not in use, always keep the cup holder stored while driving to reduce the risk of injury in the event of a sudden stop or an accident.

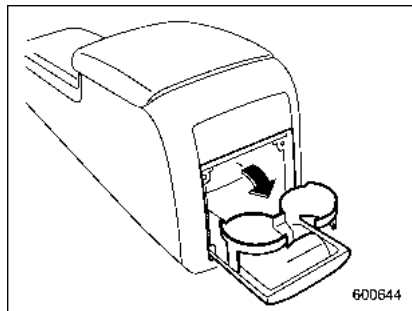

A dual cup holder is located at the back of the center console. To use the cup holder, open the lid by pulling its upper edge.

Bottle holders

CAUTION

- Do not pick up a bottle from the bottle holder or put a bottle in the holder while you are driving, as this may distract you and lead to an accident.
- When placing a beverage in a bottle holder, make sure it is capped. Otherwise, the beverage could spill when opening/closing the door or while driving and, if the beverage is hot, it could burn you and/or your passengers.

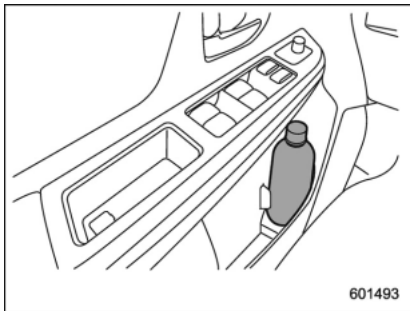

601493

The bottle holder equipped on each door

trim can be used to hold a beverage bottle and other items.

Accessory power outlets

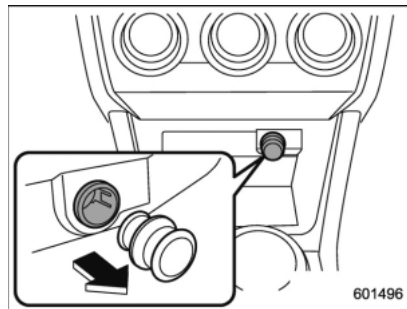

601496

Power outlet below the climate control dials

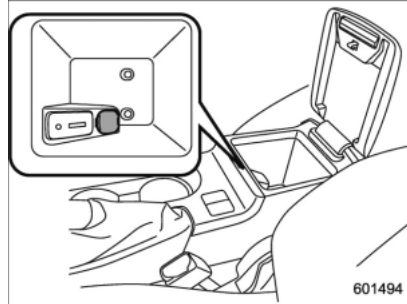

601494

Power outlet in the center console (except STI)

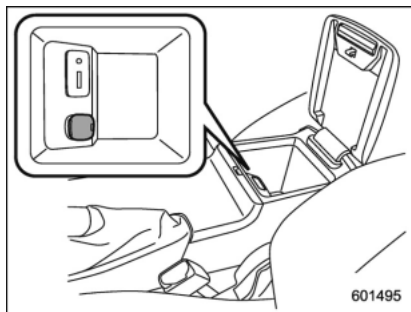

Power outlet in the center console (STI)

Accessory power outlets are provided below the climate control dials and in the center console. Electrical power (12V DC) from the battery is available at any of the outlets when the ignition switch is in either the "ACC" or "ON" position.

You can use an in-vehicle electrical appliance by connecting it to an outlet.

The maximum power rating of an appliance that can be connected is **120W**. Do not use an appliance which exceeds the indicated wattage for each outlet.

When using appliances connected to two or more outlets simultaneously, the total power consumed by them must not exceed 120W.

CAUTION

- Do not attempt to use a cigarette lighter in the accessory power outlets.
- Do not place any foreign objects, especially metal ones such as coins or aluminum foil, into the accessory power outlet. That could cause a short circuit. Always put the cap on the accessory power outlet when it is not in use.
- Use only electrical appliances which are designed for 12V DC. The maximum power rating of an appliance that can be connected is 120W. Do not use an appliance which exceeds the indicated wattage for each outlet.

When using appliances connected to two or more outlets simultaneously, the total power consumed by them must not exceed 120W. Overloading the accessory power outlet can cause a short circuit. Do not use double adapters or more than one electrical appliance.

- If the plug on your electric appliance is either too loose or too

tight for the accessory power outlet, this can result in a poor contact or cause the plug to get stuck. Only use plugs that fit properly.

- Use of an electric appliance in the accessory power outlet for a long period of time while the engine is not running can cause battery discharge.
- Before driving your vehicle, make sure that the plug and the cord on your electrical appliance will not interfere with your shifting gears and operating the accelerator and brake pedals. If they do, do not use the electrical appliance while driving.

■ Use with a cigarette lighter (if equipped)

To use the accessory power outlet as a cigarette lighter socket, purchase the cigarette lighter plug, which is an optional accessory. A cigarette lighter plug is available from your SUBARU dealer.

The cigarette lighter operates only when the ignition switch is in the "ON" or "ACC" position.

To use the cigarette lighter, push in the

knob and wait a few moments. It will automatically spring up when ready for use.

 **WARNING**

To avoid being burned, never grasp the lighter by the end with the heating element. Doing so could result in injury and could also damage the heating element.

 **CAUTION**

- Do not hold the lighter pushed in, because it will overheat.
- The electrical power socket is originally designed to use a genuine SUBARU cigarette lighter plug. Do not use a non-genuine cigarette lighter plug in the socket. Doing so may cause a short-circuit and overheating, resulting in a fire.
- If the socket is ever used for a plug-in accessory such as a cell phone, that may damage the portion of the socket's internal mechanism that causes a cigarette lighter plug to "pop out" after its lighter element is heated. Therefore, do not place a cigar-

ette lighter plug in a socket that has been used, even once, to power a plug-in accessory. Doing so may cause the plug to stick and overheat, creating a potential fire hazard.

Ashtray (if equipped)

 **CAUTION**

- Do not use ashtrays as waste receptacles or leave a lighted cigarette in an ashtray. This could cause a fire.
- Always extinguish matches and cigarettes before putting them into the ashtray, and then close the ashtray securely. If you keep the ashtray open, the fire of the cigarette may spread to another cigarette butt and start a fire.
- Do not put flammable material in the ashtray.
- Do not leave a lot of cigarette butts in the ashtray.

NOTE

Particles of ash and tobacco will accumulate around the hinges of the ashtray's inner lid. Clean them off using a toothbrush or a similar narrow-ended implement.

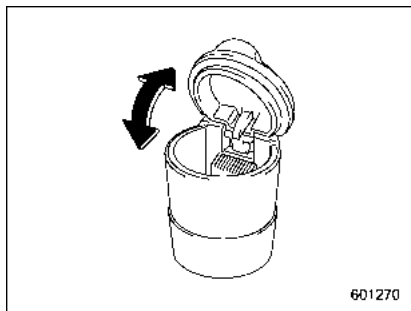

The portable ashtray can be installed in each cup holder or bottle holder. For the locations of the cup holders, refer to “Cup holders” ¶6-5. For the locations of the bottle holders, refer to “Bottle holders” ¶6-7.

When using the ashtray, open the lid of the ashtray. Fully close the lid after using the ashtray to help reduce residual smoke.

Floor mat (if equipped)

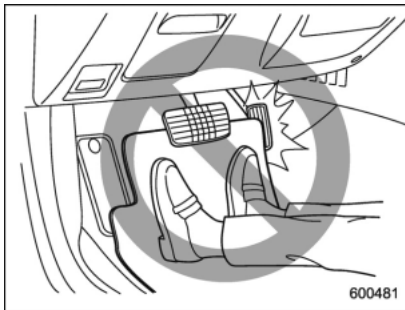

CAUTION

If the floor mat slips forward and interferes with the movement of the pedals during driving, it could cause an accident. Observe the following precautions to prevent the floor mat from slipping forward.

- Be sure to use a genuine SUBARU floor mat or an equivalent designed with grommets in the correct locations.
- Make sure that the driver's floor mat is placed in its proper location and is correctly secured on its retaining pins.

- Do not use more than one floor mat.

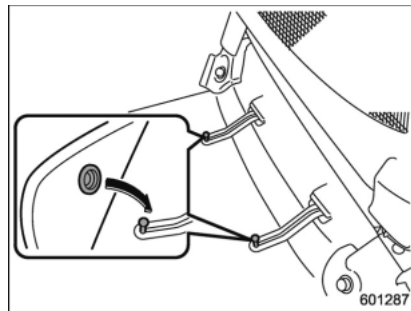

Retaining pins are located on the driver's side floor.

The floor mat should be properly secured using the built-in grommets, by placing the grommets over the pins and pushing them downward.

Coat hook

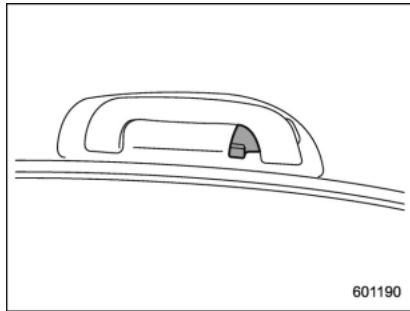

A coat hook is attached to the rear passenger's hand grip.

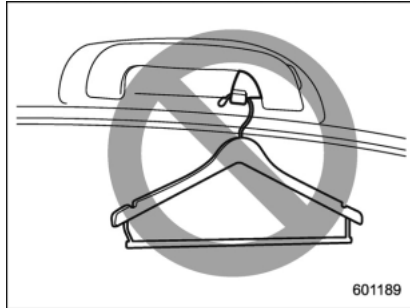

WARNING

Hang clothing directly on the coat hooks without using hangers. Do not hang coat hangers or other hard or pointed objects on the coat hooks. If such items are hanging on the coat hooks, when the SRS curtain airbags deploy, they could cause serious injuries by coming off the coat hooks and being thrown through the cabin or by preventing correct airbag deployment. Before hanging clothing on the coat hooks, make sure there are no pointed objects in the pockets.

CAUTION

Never hang anything on the coat hook that might obstruct the driver's view or that could cause injury in sudden stops or in a collision.

Under-floor storage compartment

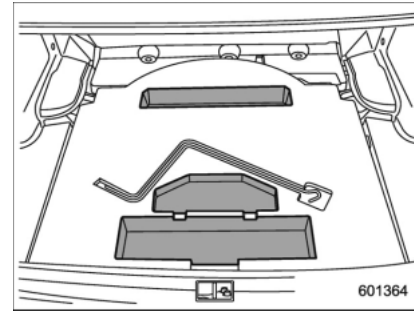

The storage compartment is located under the floor of the trunk and can be used to store small items. Pull the strap to open the trunk floor lid, and then remove the lid.

NOTE

- The shape of the storage compartment may be different depending on the model.
- When storing a flat tire, put the storage tray in the trunk.

CAUTION

- Always keep the lids closed while driving to reduce the risk of

injury in the event of a sudden stop or an accident.

- Do not store spray cans, containers with flammable or corrosive liquids or any other dangerous items in the storage compartment.

Rear view camera (if equipped)

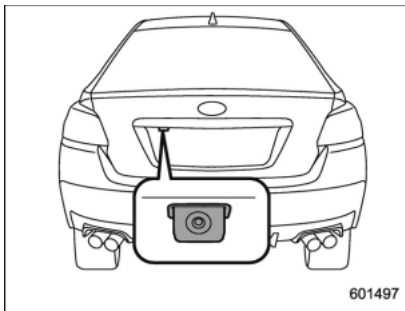

A rear view camera is attached to the trunk lid. When the ignition switch is "ON" and the shift lever (MT models) or select lever (CVT models) is set to "R", the rear view camera automatically displays the rear view image behind the vehicle on the multi function display.

WARNING

- Since the rear view camera uses a wide-angle lens, the image on the monitor is different from the actual view in terms of distance.
- Since the range and field of view of the image on the monitor is

limited, you should always check the rear view and the surrounding area with your eyes and mirrors, and move backward at a slow speed. Moving backward only by checking the rear view image from the camera could cause an accident.

- Do not disassemble or modify the camera, switch or wiring. If smoke comes out or you smell a strange odor, stop using the rear view camera immediately. Contact your SUBARU dealer for an inspection. Continued use may result in accident, fire or electric shock.

CAUTION

- If your vehicle is washed with a high-pressure washer, do not allow water to contact the camera directly. Entry of water into the camera lens may result in condensation, malfunction, fire or electric shock.
- Since the camera is a precision device, do not subject it to strong impacts. Otherwise, malfunction, fire or electric shock may occur.

- If mud or snow sticks to or is frozen on the camera, you must be very careful when removing it. Otherwise, damage to the camera may cause a fire or electric shock. Pour water or lukewarm water over the camera to remove mud and ice, and wipe it with a soft, dry cloth.
- Do not put a flame close to the camera or wiring. Otherwise, damage or fire may occur.
- When replacing the fuse, be sure to use a fuse with the specified rating. Use of a fuse with a different rating may result in a malfunction.
- If the rear view camera is used for a long time while the engine is not operated, the battery may become completely discharged.

NOTE

- Do not wipe the camera with alcohol, benzine or paint thinner. Otherwise, discoloration may occur. To remove contamination, wipe the camera with a cloth moistened with a diluted neutral detergent and then wipe it with a soft, dry cloth.
- When waxing the vehicle, be careful

not to apply the wax to the camera. If it comes in contact with the camera, moisten a clean cloth with a diluted neutral detergent to remove the wax.

- The camera lens has a hard coating to help prevent scratches. However, when washing the vehicle or cleaning the camera lens, be careful not to scratch the camera lens. Do not use a washing brush directly on the camera lens. The image quality of the rear view camera may deteriorate.
- Strong light shined on the camera lens may develop vertical lines around the light source. This is not a malfunction.
- Under fluorescent light, the display may flicker. However, this is not a malfunction.
- The image of the rear view camera may be slightly different from the actual color of the objects.

■ How to use the rear view camera

When the shift lever/select lever is set to "R", the rear view camera automatically displays the rear view image from the vehicle. When the lever is set to other positions, the image before setting to "R" is displayed.

1. Set the ignition switch to "ON".

2. Set the shift lever/select lever to "R".

You can set the rear view image to remain displayed for a certain time if the shift lever/select lever is set to a position other than "R". Refer to "Rear view camera image display delayed-off function setting"  3-76.

NOTE

- The image of the rear view camera has priority over other screen displays.
- The image of the rear view camera is horizontally reversed as is the case with the vehicle rearview mirror or the side view mirror.
- It may be difficult to see the image of the rear view camera in the following cases. This is not a malfunction of the camera.
 - The vehicle is in a dark place (at night, in a tunnel, etc.).
 - The vehicle is in an extremely hot or cold place.
 - An object (such as raindrops, snow, dirt, etc.) that disturbs the view of the rear view camera sticks to the lens of the camera.
 - Strong light shined directly on the camera lens (occasionally, there are vertical lines on the screen).

■ Viewing range on the screen



The range that can be viewed with the rear view camera is limited. Always be sure to check with your eyes when moving backward and proceed slowly.

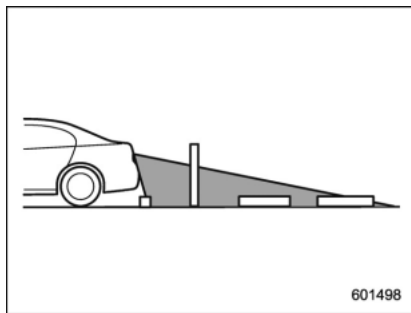

Range of view

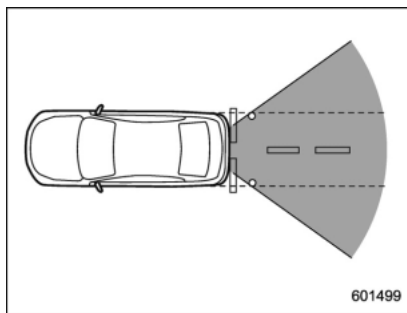

Range of view

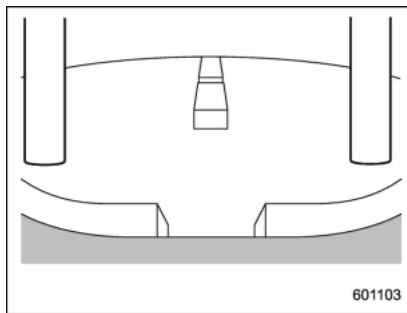
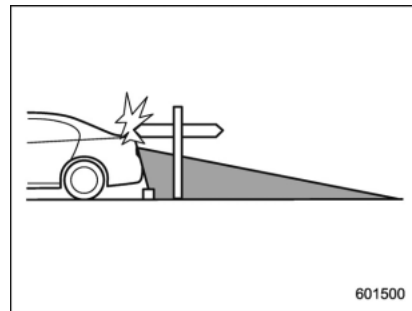

Image from camera

The area from the rear end of the bumper can be viewed. Areas at both ends of the bumper and areas just under the bumper cannot be viewed.

Also, the image from the rear view camera looks shorter than the actual distance.



Range of view

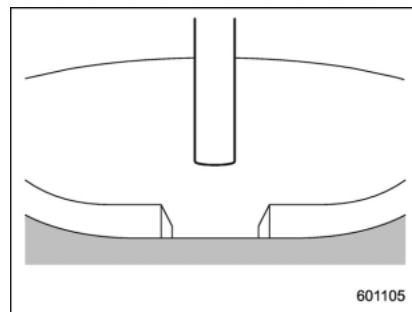

Image from camera

The area above the camera cannot be viewed. If there is an object that has a

wide projection on its upper part such as a sign pole behind the vehicle, the projection cannot be seen on the screen.

■ Help line

The help line (distance marker and vehicle width line) is a guide to help you realize the actual distance from the screen image.

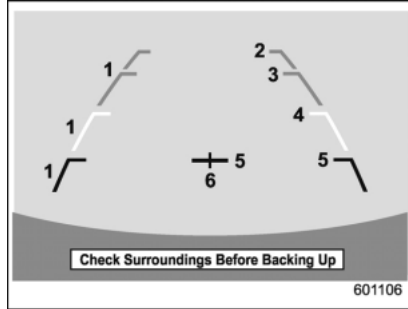

- 1) Vehicle width line (oblique vertical line)
- 2) Approx. 10 feet (3 m) from the bumper (green horizontal line)
- 3) Approx. 6.5 feet (2 m) from the bumper (green horizontal line)
- 4) Approx. 3 feet (1 m) from the bumper (yellow horizontal line)
- 5) Approx. 1.5 feet (0.5 m) from the bumper (red horizontal line)
- 6) Vehicle centerline

When the shift lever/select lever is set to position "R", the monitor screen displays

the help lines together with the rear view image.

⚠ CAUTION

- When moving backward, always check the back with your eyes without relying on the help lines.
- The actual position may be different from the indication of the help lines.
- Differences may occur due to number of passengers or loaded cargo.
- When the vehicle is on a slope or when the vehicle is inclined against the road, the indication is different from the actual position.

▼ Difference between screen image and actual road

The distance markers show the distance for a level road when the vehicle is not loaded. It may be different from the actual distance depending on the loading conditions or road conditions.

▽ When there is an upward slope at the back

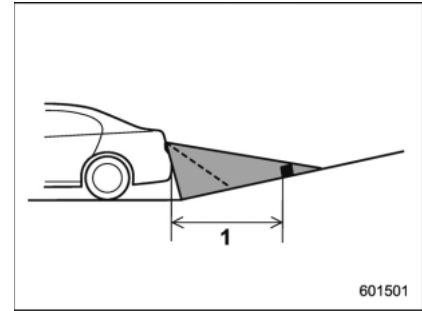

- 1) 3 feet (1 m)

The distance on the screen looks farther than the actual distance.

▽ When there is a downward slope at the back

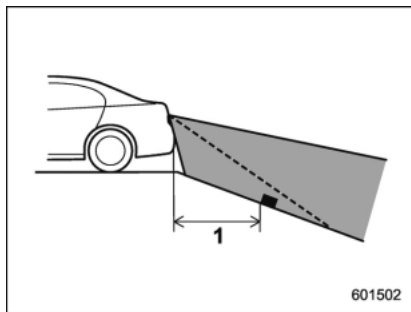

- 1) 3 feet (1 m)

The distance on the screen looks nearer than the actual distance.

NOTE

When cargo is loaded, the rear view distance on the screen looks farther than the actual distance as in an upward slope.

▼ Feature of distance marker

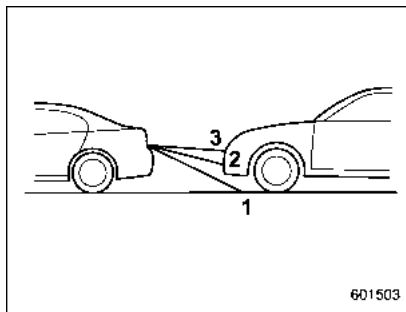

- 1) 3 feet (1 m) line
- 2) 6.5 feet (2 m) line
- 3) 10 feet (3 m) line

The distance marker shows the distance on the road. If there is a car or other object close behind, distance cannot be correctly displayed.

Fuel	7-3	Driver's Control Center Differential (C.DIFF/ DCCD) (STI)	7-19
Fuel requirements	7-3	To change mode of driver's control center differential	7-20
Fuel filler lid and cap	7-5	Auto mode	7-20
State emission testing (U.S. only)	7-7	Manual mode	7-21
Preparing to drive	7-8	Temporary release	7-23
Starting and stopping the engine (models without push-button ignition switch)	7-9	Continuously variable transmission	7-23
Starting engine	7-9	Select lever	7-24
Stopping the engine	7-11	Selection of manual mode	7-25
Starting and stopping engine (models with push-button start system)	7-12	Shift lock function	7-27
Safety precautions	7-12	Driving tips	7-28
Operating range for push-button start system	7-12	SI-DRIVE (STI)	7-28
Starting engine	7-12	Intelligent (I) mode	7-28
Stopping engine	7-14	Sport (S) mode	7-29
When access key does not operate properly	7-14	Sport Sharp (S#) mode	7-29
Remote engine start system (dealer option)	7-14	SI-DRIVE selector	7-30
Models with "keyless access with push-button start system"	7-15	SI-DRIVE (except STI: CVT models)	7-30
Entering the vehicle while it is running via remote start	7-16	Intelligent (I) mode	7-30
Entering the vehicle following remote engine start shutdown	7-16	Sport (S) mode	7-31
Pre-heating or pre-cooling the interior of the vehicle	7-16	Sport Sharp (S#) mode	7-31
System maintenance	7-16	SI-DRIVE switches	7-32
Manual transmission	7-16	Limited slip differential (LSD) (STI)	7-32
Shifting speeds	7-17	Power steering	7-33
Driving tips	7-18	STI	7-33
		Except STI	7-33
		Braking	7-34
		Braking tips	7-34
		Brake system	7-34
		Disc brake pad wear warning indicators	7-35

ABS (Anti-lock Brake System)	7-35	Parking tips	7-43
ABS system self-check.....	7-36	Hill start assist system	7-44
ABS warning light	7-36	To activate/deactivate the Hill start assist system	7-46
Electronic Brake Force Distribution (EBD) system	7-36	Hill start assist warning light/Hill start assist OFF indicator light	7-47
Steps to take if EBD system malfunctions.....	7-37	Cruise control	7-47
Vehicle Dynamics Control system	7-38	To set cruise control.....	7-48
Vehicle Dynamics Control system monitor	7-39	To temporarily cancel the cruise control.....	7-49
Vehicle Dynamics Control OFF switch.....	7-40	To turn off the cruise control.....	7-49
Tire pressure monitoring system (TPMS) (U.S.-spec. models)	7-41	To change the cruising speed	7-49
Parking your vehicle	7-43	Cruise control indicator	7-50
Parking brake.....	7-43	Cruise control set indicator.....	7-50

Fuel



CAUTION

Use of a fuel which is low in quality or use of an inappropriate fuel additive may cause engine damage.

■ Fuel requirements

▼ STI

The engine is designed to operate at maximum performance using **unleaded gasoline** with an octane rating of **93 AKI (98 RON) or higher**. If 93 AKI (98 RON) fuel is not readily available in your area, unleaded gasoline with an octane rating of 91 AKI (95 RON) may be used with no detriment to engine durability or driveability. However, you may notice a slight decrease in maximum engine performance while using 91 AKI (95 RON) fuel. Use of 91 AKI (95 RON) fuel will not affect your warranty coverage.

▼ Except STI

The engine is designed to operate using **unleaded gasoline** with an octane rating of **91 AKI (95 RON) or higher**. If 91 AKI (95 RON) fuel is not readily available, unleaded gasoline with an octane rating of

87 AKI (90 RON) may be temporarily used.

For optimum engine performance and driveability, it is recommended that you use premium grade unleaded gasoline.

Regular unleaded gasoline with an octane rating of 87 AKI (90 RON) or higher may also be used. Using regular unleaded gasoline will not be detrimental to engine durability, nor will it affect your warranty coverage. However, depending on your driving habits and conditions, you may notice a decrease in maximum engine performance, fuel economy or slight engine vibration or knocking. If you experience any of these conditions while using a lower octane rated fuel, you may want to return to using 91 AKI (95 RON) octane rated fuel as soon as possible. Additionally, if your vehicle knocks heavily or persistently, the use of 91 AKI (95 RON) or higher grade unleaded gasoline is required.

▼ Fuel octane rating

This octane rating is the average of the Research Octane and Motor Octane numbers and is commonly referred to as the Anti Knock Index (AKI).

Using a gasoline with a lower octane rating can cause persistent and heavy knocking, which can damage the engine.

Do not be concerned if your vehicle sometimes knocks lightly when you drive up a hill or when you accelerate. Contact your SUBARU dealer if you use a fuel with the specified octane rating and your vehicle knocks heavily or persistently.

▼ Unleaded gasoline

The neck of the fuel filler pipe is designed to accept only an unleaded gasoline filler nozzle. Under no circumstances should leaded gasoline be used because it will damage the emission control system and may impair driveability and fuel economy.

▼ Gasoline for California-certified LEV

If your vehicle was certified to California's low emission vehicle (LEV) standards as indicated on the underhood tune-up label, it is designed to optimize engine and emission performance with gasoline that meets the clean burning low-sulfur California gasoline specifications. If you live in any other state than California, your vehicle will operate on gasoline meeting Federal specifications. Gasoline sold outside California is permitted to have higher sulfur levels, which may affect the performance of your vehicle's catalytic converter and may produce a sulfur exhaust odor or smell. SUBARU recommends that you try a different brand of unleaded gasoline

having lower sulfur to determine if the problem is fuel related before returning your vehicle to an authorized dealer for service.

▼ MMT

Some gasoline contains an octane-enhancing additive called MMT (Methylcyclopentadienyl Manganese Tricarbonyl). If you use such fuels, your emission control system performance may deteriorate and the CHECK ENGINE warning light/Malfunction indicator light may turn on. If this happens, return to your authorized SUBARU Dealer for service. If it is determined that the condition is caused by the type of fuel used, repairs may not be covered by your warranty.

▼ Gasoline for cleaner air

Your use of gasoline with detergent additives will help prevent deposits from forming in your engine and fuel system. This helps keep your engine in tune and your emission control system working properly, and is a way of doing your part for cleaner air. If you continuously use a high quality fuel with the proper detergent and other additives, you should never need to add any fuel system cleaning agents to your fuel tank.

Many gasolines are now blended with materials called oxygenates. Use of these

fuels can also help keep the air cleaner. Oxygenated blend fuels, such as MTBE (Methyl Tertiary Butyl ether) or ethanol (ethyl or grain alcohol) may be used in your vehicle, but should contain no more than 15% MTBE or 10% ethanol for the proper operation of your SUBARU.

Do not use any gasoline that contains more than 10% ethanol, including from any pump labeled E15, E30, E50 or E85 (which are only some examples of fuel containing more than 10% ethanol).

In addition, some gasoline suppliers are now producing reformulated gasolines, which are designed to reduce vehicle emissions. SUBARU approves the use of reformulated gasoline.

If you are not sure what the fuel contains, you should ask your service station operators if their gasolines contain detergents and oxygenates and if they have been reformulated to reduce vehicle emissions.

As additional guidance, only use fuels suited for your vehicle as explained in the following description.

- Fuel should be unleaded and have an octane rating no lower than that specified in this manual.
- Methanol (methyl or wood alcohol) is

sometimes mixed with unleaded gasoline. Methanol can be used in your vehicle **ONLY** if it does not exceed 5% of the fuel mixture **AND** if it is accompanied by sufficient quantities of the proper cosolvents and corrosion inhibitors required to prevent damage to the fuel system. Do not use fuel containing methanol **EXCEPT** under these conditions.

- If undesirable driveability problems are experienced and you suspect they may be fuel related, try a different brand of gasoline before seeking service at your SUBARU dealer.
- Fuel system damage or driveability problems which result from the use of improper fuel are not covered under the SUBARU Limited Warranty.



CAUTION

Do not let fuel spill on the exterior surfaces of the vehicle. Because fuel may damage the paint, be sure to wipe off any spilled fuel quickly. Paint damage caused by spilled fuel is not covered under the SUBARU Limited Warranty.

■ Fuel filler lid and cap

▼ Refueling

Only one person should be involved in refueling. Do not allow others to approach the area of the vehicle near the fuel filler pipe while refueling is in progress. Be sure to observe any other precautions that are posted at the service station.

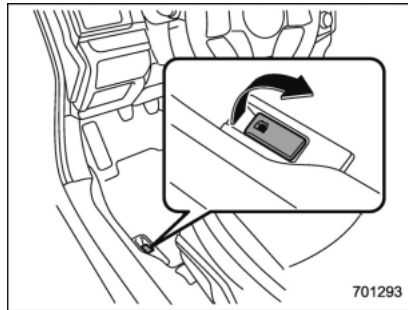
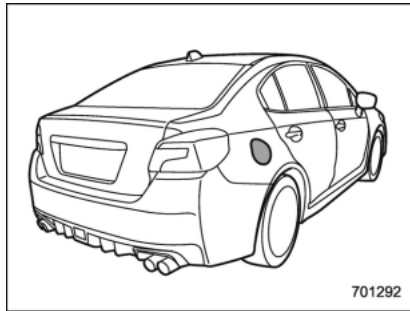

1. To open the fuel filler lid, pull the lid release lever up. The lever is on the floor at the left of the driver's seat.

WARNING

Before opening the fuel filler cap, first touch the vehicle body or a metal portion of the fuel pump or similar object to discharge any static electricity that may be present on your body. If your body is carrying an electrostatic charge, there is a possibility that an electric spark could ignite the fuel, which could burn you. To avoid acquiring a new static electric charge, do not get back into the vehicle while refueling is in progress.

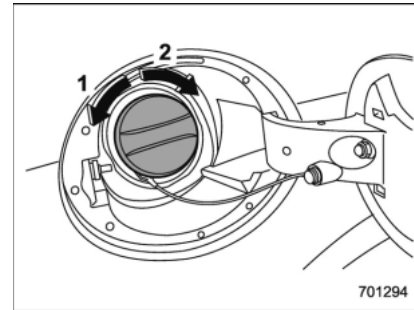

- 1) Open
- 2) Close

2. Remove the fuel filler cap by turning it slowly counterclockwise.

WARNING

- Gasoline vapor is highly flammable. Before refueling, always first stop the engine and close all vehicle doors and windows. Make sure that there are no lighted cigarettes, open flames or electrical sparks in the adjacent area. Only handle fuel outdoors. Quickly wipe up any spilled fuel.
- When opening the cap, grasp it firmly and turn it slowly to the

left. Do not remove the cap quickly. Fuel may be under pressure and spray out of the fuel filler neck, especially in hot weather. If you hear a hissing sound while you are removing the cap, wait for the sound to stop and then slowly open the cap to prevent fuel from spraying out and creating a fire hazard.

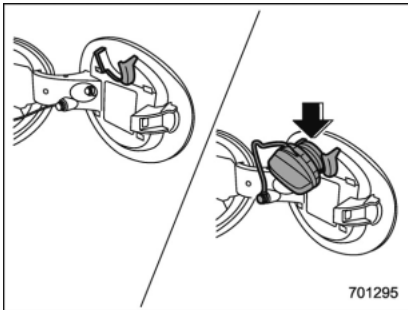

3. Set the fuel filler cap on the cap holder inside the fuel filler lid.

WARNING

- When refueling, insert the fuel nozzle securely into the fuel filler pipe. If the nozzle is lifted or not fully inserted, its automatic stop-

ping mechanism may not function, causing fuel to overflow the tank and creating a fire hazard.

- Stop refueling when the automatic stop mechanism on the fuel nozzle activates. If you continue to add fuel, temperature changes or other conditions may cause fuel to overflow from the tank and create a fire hazard.

4. Stop filling the tank after the fuel filler pump automatically stops. Do not add any more fuel.

5. Put the cap back on, turn it clockwise until you hear a clicking noise. Be certain not to catch the tether under the cap while tightening.

6. Close the fuel filler lid completely.

If you spill any fuel on the painted surface, rinse it off immediately. Otherwise, the painted surface could be damaged.

NOTE

- You will see the “▶” sign in the fuel gauge. This indicates that the fuel filler door (lid) is located on the right side of the vehicle.
- If the fuel filler cap is not tightened until it clicks or if the tether is caught under the cap, the CHECK ENGINE

warning light/malfunction indicator light may illuminate. Refer to “CHECK ENGINE warning light/Malfunction indicator light” 3-16.

CAUTION

- Never add any cleaning agents to the fuel tank. The addition of a cleaning agent may cause damage to the fuel system.
- After refueling, turn the cap clockwise until it clicks to ensure that it is fully tightened. If the cap is not securely tightened, fuel may leak out while the vehicle is being driven or fuel spillage could occur in the event of an accident, creating a fire hazard.
- Do not let fuel spill on the exterior surfaces of the vehicle. Because fuel may damage the paint, be sure to wipe off any spilled fuel quickly. Paint damage caused by spilled fuel is not covered under the SUBARU Limited Warranty.
- Always use a genuine SUBARU fuel filler cap. If you use the wrong cap, it may not fit or have proper venting and your fuel tank and emission control system may be damaged. It could also

lead to fuel spillage and a fire.

- Immediately put fuel in the tank whenever the low fuel warning light illuminates. Engine misfires as a result of an empty tank could cause damage to the engine.

State emission testing (U.S. only)

WARNING

Testing of an All-Wheel Drive model must **NEVER** be performed on a single two-wheel dynamometer. Attempting to do so will result in uncontrolled vehicle movement and may cause an accident or injuries to persons nearby.

CAUTION

- At state inspection time, remember to tell your inspection or service station in advance not to place your SUBARU AWD vehicle on a two-wheel dynamometer. Otherwise, serious transmission damage will result.
- Resultant vehicle damage due to improper testing is not covered under the SUBARU Limited Warranty and is the responsibility of the state inspection program or its contractors or licensees.

California and a number of federal states

have Inspection/Maintenance programs to inspect your vehicle's emission control system. If your vehicle does not pass this test, some states may deny renewal of your vehicle's registration.

Your vehicle is equipped with a computer that monitors the performance of the engine's emission control system. Certified emission inspectors will inspect the On-Board Diagnostic (OBDII) system as part of the state emission inspection process. The OBDII system is designed to detect engine and transmission problems that might cause the vehicle emissions to exceed allowable limits. OBDII inspections apply to all 1996 model year and newer passenger cars and trucks. Over 30 states plus the District of Columbia have implemented emission inspection of the OBDII system.

- The inspection of the OBDII system consists of a visual operational check of the "CHECK ENGINE" warning light/malfunction indicator light (MIL) and an examination of the OBDII system with an electronic scan tool.
- A vehicle passes the OBDII system inspection if proper operation of the "CHECK ENGINE" warning light is observed, there are no stored diagnostic trouble codes, and the OBDII readiness monitors are all complete.

- A vehicle fails the OBDII inspection if the “**CHECK ENGINE**” warning light is not properly operating (light is illuminated or is not working due to a burned out bulb) or there is one or more diagnostic trouble codes stored in the vehicle’s computer.

- A state emission inspection may reject (not pass or fail) a vehicle if the number of OBDII system readiness monitors “**NOT READY**” is greater than one. If the vehicle’s battery has been recently replaced or disconnected, the OBDII system inspection may indicate that the vehicle is not ready for the emission test. Under this condition, the vehicle driver should be instructed to drive his/her vehicle for a few days to reset the readiness monitors and return for an emission re-inspection.

- Owners of rejected or failing vehicles should contact their SUBARU Dealer for service.

Some states still use dynamometers in their emission inspection program. A dynamometer is a treadmill or roller-like testing device that allows your vehicle’s wheels to turn while the vehicle remains in one place. Prior to your vehicle being put on a dynamometer, tell your emission inspector not to place your SUBARU AWD vehicle on a two-wheel dynamometer. **Otherwise, serious transmission damage will result.**

The U.S. Environmental Protection Agency (EPA) and states using two-wheel dynamometers in their emission testing program have EXEMPTED SUBARU AWD vehicles from the portion of the testing program that involves a two-wheel dynamometer. There are some states that use four-wheel dynamometers in their testing program. When properly used, this equipment should not damage a SUBARU AWD vehicle.

Under no circumstances should the rear wheels be jacked off the ground, nor should the driveshaft be disconnected for state emission testing.

Preparing to drive

You should perform the following checks and adjustments every day before you start driving.

1. Check that all windows, mirrors, and lights are clean and unobstructed.
2. Check the appearance and condition of the tires. Also check tires for proper inflation.
3. Look under the vehicle for any sign of leaks.
4. Check that the hood and trunk lid are fully closed.
5. Check the adjustment of the seat.
6. Check the adjustment of the inside and outside mirrors.
7. Fasten your seatbelt. Check that your passengers have fastened their seatbelts.
8. Check the operation of the warning and indicator lights when the ignition switch is turned to the “ON” position.
9. Check the gauges, indicator and warning lights after starting the engine.

NOTE

- **Engine oil, engine coolant, brake fluid, washer fluid and other fluid levels should be checked daily, weekly or at fuel stops.**

- Check that there are no small animals such as cats or mice inside the engine compartment or under the vehicle. There is a possibility that when starting the engine those small animals may be caught by the cooling fan or belts, which could cause a vehicle malfunction as well as injury or death to the animals themselves.

Starting and stopping the engine (models without push-button ignition switch)

■ Starting engine

CAUTION

Do not operate the starter motor continuously for more than 10 seconds. If the engine fails to start after operating the starter for 5 to 10 seconds, wait for 10 seconds or more before trying again.

NOTE

It may be difficult to start the engine when the battery has been disconnected and reconnected (for maintenance or other purposes). This difficulty is caused by the electronically controlled throttle's self-diagnosis function. To overcome it, keep the ignition switch in the "ON" position for approximately 10 seconds before starting the engine.

- ▼ General precautions when starting engine

WARNING

- Never start the engine from outside the vehicle. It may result in an accident.
- Do not leave the engine running in locations with poor ventilation, such as a garage and indoors. The exhaust gas may enter the vehicle or indoors, and it may result in carbon monoxide poisoning.
- Do not start the engine near dry foliage, paper, or other flammable substances. The exhaust pipe and exhaust emissions can create a fire hazard at high temperatures.

CAUTION

- If the engine is stopped during driving, the catalyst may overheat and burn.

- When starting the engine, be sure to sit in the driver's seat (except when using the remote engine start system).

NOTE

- Avoid rapid racing and rapid acceleration immediately after the engine has started.
- For a short time after the engine has started, the engine speed is kept high. When the warm-up is completed, the engine speed lowers automatically.
- On rare occasions, it may be difficult to start the engine depending on the fuel and the usage condition (repeated driving of a distance in which the engine has not warmed up sufficiently). In such a case, it is recommended that you change to a different brand of fuel.
- On rare occasions, transient knocking may be heard from the engine when the accelerator is operated rapidly such as a rapid start-up and a rapid acceleration. This is not a malfunction.
- The engine starts more easily when the headlights, air conditioner and rear window defogger are turned off.
- After the engine starts, the engine speed will be kept high until the engine has warmed up sufficiently.

▼ MT models

1. Apply the parking brake.
2. Turn off unnecessary lights and accessories.
3. Depress the clutch pedal to the floor and shift the shift lever into neutral. Hold the clutch pedal to the floor while starting the engine.

The starter motor will only operate when the clutch pedal is depressed fully to the floor.

4. Turn the ignition switch to the "ON" position and check the operation of the warning and indicator lights. Refer to "Warning and indicator lights" 3-13.
5. Turn the ignition switch to the "START" position **without** depressing the accelerator pedal. Release the key immediately after the engine has started.

If the engine does not start, try the following.

- (1) Turn the ignition switch to the "LOCK" position and wait for at least 10 seconds. After checking that the parking brake is firmly set, turn the ignition switch to the "START" position while depressing the accelerator pedal slightly (approximately a quarter of the full stroke). Release the accelerator pedal as soon as the engine starts.

- (2) If this fails to start the engine, turn

the ignition switch back to the "LOCK" position and wait for at least 10 seconds. Then fully depress the accelerator pedal and turn the ignition switch to the "START" position. If the engine starts, quickly release the accelerator pedal.

(3) If this fails to start the engine, turn the ignition switch again to the "LOCK" position. After waiting for 10 seconds or longer, turn the ignition switch to the "START" position without depressing the accelerator pedal.

(4) If the engine still refuses to start, contact your nearest SUBARU dealer for assistance.

6. Confirm that all warning and indicator lights have turned off after the engine has started. The fuel injection system automatically lowers the idle speed as the engine warms up.

▼ CVT models

1. Apply the parking brake.
2. Turn off unnecessary lights and accessories.
3. Shift the select lever to the "P" or "N" position (preferably the "P" position).

The starter motor will only operate when the select lever is at the "P" or "N" position.

4. Turn the ignition switch to the "ON"

position and check the operation of the warning and indicator lights. Refer to "Warning and indicator lights" 3-13.

5. Turn the ignition switch to the "START" position **without** depressing the accelerator pedal. Release the key immediately after the engine has started.

If the engine does not start, try the following.

(1) Turn the ignition switch to the "LOCK" position and wait for at least 10 seconds. After checking that the parking brake is firmly set, turn the ignition switch to the "START" position while depressing the accelerator pedal slightly (approximately a quarter of the full stroke). Release the accelerator pedal as soon as the engine starts.

(2) If this fails to start the engine, turn the ignition switch back to the "LOCK" position and wait for at least 10 seconds. Then fully depress the accelerator pedal and turn the ignition switch to the "START" position. If the engine starts, quickly release the accelerator pedal.

(3) If this fails to start the engine, turn the ignition switch again to the "LOCK" position. After waiting for 10 seconds or longer, turn the ignition switch to the "START" position without depressing the accelerator pedal.

(4) If the engine still refuses to start, contact your nearest SUBARU dealer for assistance.

6. Confirm that all warning and indicator lights have turned off after the engine has started. The fuel injection system automatically lowers the idle speed as the engine warms up.

While the engine is warming up, make sure that the select lever is at the "P" or "N" position and that the parking brake is applied.



CAUTION

If you restart the engine while the vehicle is moving, shift the select lever into the "N" position. Do not attempt to place the select lever of a moving vehicle into the "P" position.

■ Stopping the engine

The ignition switch should be turned off only when the vehicle is stopped and the engine is idling.



WARNING

Do not stop the engine when the vehicle is moving. This will cause loss of power to the power steering

and the brake booster, making steering and braking more difficult. It could also result in accidental activation of the "LOCK" position on the ignition switch, causing the steering wheel to lock.

Starting and stopping engine (models with push-button start system)

■ Safety precautions

Refer to "Safety precautions" ④2-8.

■ Operating range for push-button start system

Refer to "Operating range for push-button start system" ④3-6.

■ Starting engine

WARNING

- There are some general precautions when starting the engine. Carefully read the precautions described in "General precautions when starting engine" ④7-9.
- If the indicator on the push-button ignition switch flashes in green after the engine has started, never drive the vehicle. The steering is still locked, and it may result in an accident.

CAUTION

- When the operation indicator on the push-button ignition switch is flashing in orange, there may be a malfunction with the vehicle. Contact a SUBARU dealer immediately.
- If the indicator on the push-button ignition switch is flashing in green after the engine has started, it means that the steering is still locked. Depress the brake pedal while moving the steering wheel to the right and left, and press the push-button ignition switch.
- Do not continue pushing the push-button ignition switch for more than 10 seconds. Doing so could cause a malfunction. If the engine does not start, stop pushing the push-button ignition switch and turn off the engine. Wait 10 seconds, and then push the push-button ignition switch to start the engine.

NOTE

- When the push-button ignition switch is pressed while depressing

the clutch pedal (MT models) or the brake pedal (CVT models), the engine starter operates for a maximum of 10 seconds and after starting the engine, the starter stops automatically.

- When the push-button ignition switch is pressed while depressing the clutch pedal (MT models) or the brake pedal (CVT models), the engine can be started regardless of the status of the push-button ignition switch.

- If the security indicator light illuminates when you attempt to start the engine but the engine does not start, press the push-button ignition switch to switch the power to "OFF" and then try to start the engine again.

- If the engine does not start, press the push-button ignition switch without depressing the clutch pedal (MT models) or the brake pedal (CVT models) to switch the power to "OFF". Then, while depressing the clutch pedal (MT models) or the brake pedal (CVT models) more forcefully, press the push-button ignition switch.

- The engine start procedures may not function depending on the radio wave conditions around the vehicle. In such a case, refer to "Starting engine" ④9-17.

- If the vehicle battery is discharged, the steering cannot be unlocked.

Charge the battery.

- After the engine starts, the engine speed will be kept high until the engine has warmed up sufficiently.

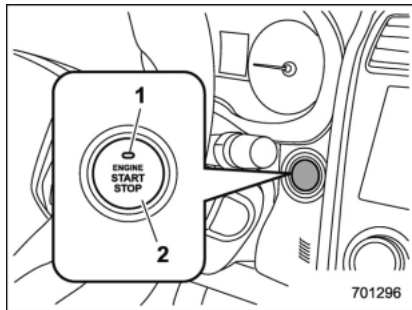

- 1) Operation indicator
- 2) Push-button ignition switch

When the push-button ignition switch is pressed while depressing the clutch pedal (MT models)/brake pedal (CVT models), the engine will start. The start procedure of the engine is as follows.

▼ MT models

1. Carry the access key, and sit in the driver's seat.
2. Apply the parking brake.
3. Shift the shift lever in neutral.
4. Depress the brake pedal.
5. Depress the clutch pedal until the

indicator on the push-button ignition switch turns green.

6. While depressing the clutch pedal, press the push-button ignition switch.

NOTE

In case the engine does not start by the normal engine start procedure, move the shift lever to the neutral position, and switch the power to "ACC". Depress the clutch pedal, and press the push-button ignition switch for at least 15 seconds. The engine may start. Only use this engine start procedure in case of emergency.

▼ CVT models

1. Carry the access key, and sit in the driver's seat.
2. Apply the parking brake.
3. Shift the select lever in the "P" position. The engine can also start when the select lever is in the "N" position, however, for safety reasons, start in the "P" position.
4. Depress the brake pedal until the operation indicator on the push-button ignition switch turns green. When starting with the select lever in the "N" position, the indicator does not turn green.
5. While depressing the brake pedal, press the push-button ignition switch.

NOTE

- While pressing the select lever button in, the indicator on the push-button ignition switch will not turn green even when the select lever is in the "P" position.
- In case the engine does not start by the normal engine start procedure, move the select lever to the "P" position, and switch the power to "ACC". Depress the brake pedal, and press the push-button ignition switch for at least 15 seconds. The engine may start. Only use this engine start procedure in case of emergency.
- When the engine is not started, the brake pedal may feel stiff. In such a case, depress the brake pedal more forcefully than usual. Check that the operation indicator on the push-button ignition switch turns green, and press the push-button ignition switch to start the engine.

■ Stopping engine

1. Stop the vehicle completely.
2. Move the select lever to the “P” position (CVT models).
3. Press the push-button ignition switch. The engine will stop, and the power will be switched to “OFF”.

WARNING

- Do not touch the push-button ignition switch during driving.

When the push-button ignition switch is operated as follows, the engine will stop.

- The switch is pressed and held for 3 seconds or longer.
- The switch is pressed briefly 3 times or more in succession.

When the engine stops, the brake booster will not function. A greater foot pressure will be required on the brake pedal.

The power steering system will not operate either. A greater force will be required to steer, and it may result in an accident.

- If the engine stops during driving, do not operate the push-button ignition switch or open any of the

doors until the vehicle is stopped in a safe location. It is dangerous because the steering lock may be activated. Stop the vehicle in a safe place, and contact a SUBARU dealer immediately.

CAUTION

For CVT models:

- Do not stop the engine while the select lever is in a position other than the “P” position.
- If the engine is stopped while the select lever is in a position other than the “P” position, the power will be in “ACC”. If the vehicle is left in this condition, the battery may be discharged.

NOTE

Although you can stop the engine by operating the push-button ignition switch, do not stop the engine during driving except in an emergency.

■ When access key does not operate properly

Refer to “Access key – if access key does not operate properly” 9-16.

Remote engine start system (dealer option)

WARNING

- There are some general precautions when starting the engine. Carefully read the precautions described in “General precautions when starting engine” 7-9.
- Do not remote start a vehicle in an enclosed environment (e.g. closed garage). Prolonged operation of a motor vehicle in an enclosed environment can cause a harmful build-up of Carbon Monoxide. Carbon Monoxide is harmful to your health. Exposure to high levels of Carbon Monoxide can cause headaches, dizziness or in extreme cases unconsciousness and/or death.
- Before performing any servicing of the vehicle, temporarily place the remote engine start system in service mode to prevent the system from unexpectedly starting the engine.

The remote engine start system allows

you to start the engine from outside the vehicle. In addition, the remote engine start system can activate the heater or air conditioner, providing you with a comfortable cabin upon entry.

■ Models with “keyless access with push-button start system”

NOTE

For more details, refer to the Owner’s Manual supplement for the remote engine start system.

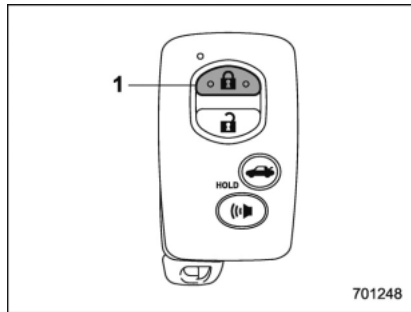

Access key

- 1) Lock button

An access key can be used as the remote engine start transmitter. Operate the lock button to start or stop the engine as

follows.

▼ Before starting the engine

Before using the remote engine start system to start the engine, confirm the following conditions.

- The select lever is in the “P” position.
- All doors are closed.
- The engine hood is closed.
- The push-button ignition switch is in the “OFF” position.

▼ Starting the engine

To start the engine with remote engine start system, briefly press the lock button twice within 2 seconds, then press and hold the lock button for 3 seconds.

1. Press the lock button briefly. The hazard warning flashers then flash once.
2. Within 2 seconds, press the lock button briefly again. The hazard warning flashers then flash once again.
3. After step 2, immediately press and hold the lock button. The hazard warning flashers then flash once.
4. Approximately 3 seconds after step 3, release the lock button. The engine will then start successfully.

▼ Stopping the engine

Press and hold the lock button to stop the engine with remote engine start system.

▼ Automatic engine shutdown

The remote engine start system will automatically shut down or will not start the engine under the following conditions.

- The total run-time has exceeded 20 minutes.
- Any door is opened.
- The select lever is moved to any position other than “P”.
- The engine hood is opened.
- The push-button ignition switch is pressed.
- The brake pedal is depressed.
- The engine speed is 3,000 rpm or more.

The time setting until the engine automatically stops can be changed. To change it, please contact your SUBARU dealer. Note that some settings may violate state, provincial, or local laws and regulations. Check the laws in your area to determine which setting is permitted.

■ Entering the vehicle while it is running via remote start

1. Unlock the vehicle doors using the keyless access function. If the vehicle's doors are unlocked manually using the key, the vehicle's alarm system will trigger (if the alarm system is armed prior to activating the remote engine start system) and the engine will turn off. Perform either of the following procedures to disarm the alarm system. Refer to "Alarm system" φ 2-21.

- Switch the ignition to the "ACC" or "ON" state by pressing the push-button ignition switch once or twice, respectively.
 - Press any button on the access key/transmitter.
2. Enter the vehicle.
 3. The engine will shut down when any door is opened.
 4. Press the push-button ignition switch while depressing the brake pedal to restart the engine.

■ Entering the vehicle following remote engine start shutdown

An alarm trigger may occur if the vehicle is opened by the remote keyless entry transmitter within a few seconds immedi-

ately following remote engine start shutdown.

■ Pre-heating or pre-cooling the interior of the vehicle

After the system starts the engine, the automatic climate control system will activate the "FULL AUTO" mode and heat or cool the interior to the predetermined median (room) temperature. No pre-setting of controls is necessary.

■ System maintenance

For models with "keyless access with push-button start system":

Perform the procedure described in "Replacing access key battery" φ 11-49.

Manual transmission

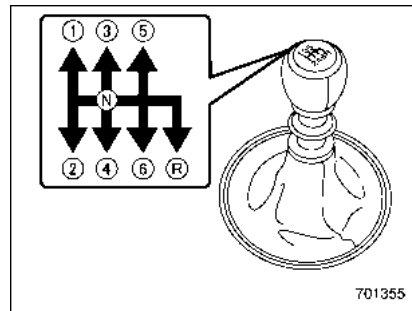

This manual transmission is a completely synchromesh, 6-forward-speed and 1-reverse-speed transmission.

The shift pattern is shown on the shift lever knob.

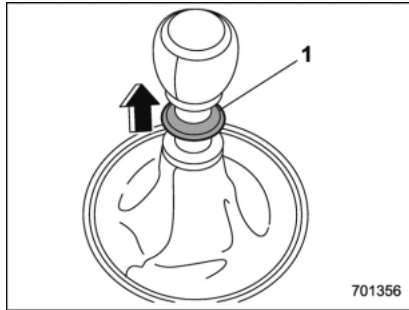

1) Slider

You must raise the slider and hold it in that position before you can move the shift lever to the "R" position.

To change gears, fully depress the clutch pedal, move the shift lever, and gradually let up on the clutch pedal.

If it is difficult to shift into gear, put the transmission in neutral, release the clutch pedal momentarily, and then try again.

⚠ WARNING

- Do not drive the vehicle with the clutch disengaged (i.e., when the clutch pedal is depressed) or with the shift lever in the neutral position. Engine braking has no effect in either of these conditions and the risk of an accident is consequently increased.
- Do not engage the clutch (i.e., release the clutch pedal) suddenly when starting the vehicle. By doing so the vehicle might unexpectedly accelerate or the transmission could malfunction.

⚠ CAUTION

Shift into reverse **ONLY** when the vehicle has completely stopped. It may cause damage to the transmission to try shifting into reverse when the vehicle is moving.

■ Shifting speeds

▼ Recommended shifting speeds

The best compromise between fuel economy and vehicle performance during normal driving is ensured by shifting up at the speeds listed in the following table.

Shift up	mph (km/h)
1st to 2nd	15 (24)
2nd to 3rd	25 (40)
3rd to 4th	40 (64)
4th to 5th	45 (72)
5th to 6th	50 (80)

▼ Shift-up indicator (STI)

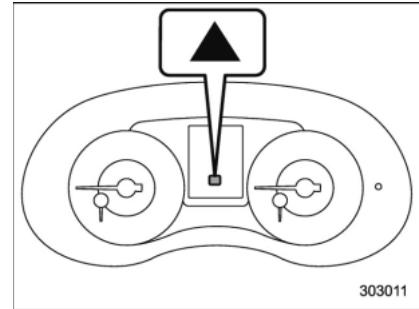

The shift-up indicator appears to inform

the driver about the upshift timing.

The shift-up indicator can be activated or deactivated. For details, refer to "Shift-up indicator (STI)" 3-31.

▼ Maximum allowable speeds

The following table shows the maximum speeds that are possible with each different gear. The tachometer's needle will enter the red area if these speeds are exceeded.

With the exception of cases where sudden acceleration is required, the vehicle should not be driven with the tachometer's needle inside the red area. Failure to observe this precaution can lead to excessive engine wear and poor fuel economy.

Gear	STI mph (km/h)	Except STI mph (km/h)
1st	31 (50)	31 (49)
2nd	51 (82)	55 (88)



WARNING

When shifting down a gear, ensure that the vehicle is not travelling at a speed exceeding the Maximum Allowable Speed for the gear which is about to be selected. Failure to observe this precaution can lead to

engine over-revving and this in turn can result in engine damage.

In addition, sudden application of engine brakes when the vehicle is travelling on a slippery surface can lead to wheel locking; as a consequence, control of the vehicle may be lost and the risk of an accident increased.

NOTE

Never exceed the posted speed limit.

■ Driving tips

Do not drive with your foot resting on the clutch pedal and do not use the clutch to hold your vehicle at a standstill on an upgrade. Either of those actions may cause clutch damage.

Do not drive with your hand resting on the shift lever. This may cause wear on the transmission components.

When it is necessary to reduce vehicle speed due to slow traffic, turning corners, or driving up steep hills, downshift to a lower gear before the engine starts to labor.

On steep downgrades, downshift the transmission to 5th, 4th, 3rd or 2nd gear

as necessary; this helps to maintain a safe speed and to extend brake pad life.

In this way, the engine provides a braking effect. Remember, if you "ride" (over use) the brakes while descending a hill, they may overheat and not work properly.

The engine may, on rare occasions, knock when the vehicle rapidly accelerates or rapidly pulls away from a standstill. This phenomenon is not an indication of a problem in your vehicle.

Driver's Control Center Differential (C.DIFF/DCCD) (STI)

WARNING

Always use the utmost care when driving. Being overconfident because you are driving a vehicle with a driver's control center differential could easily lead to a serious accident.

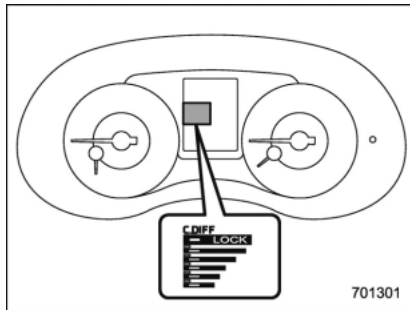

CAUTION

- All the indicators will flash in the event that the driver's control center differential has a malfunction.

tion. Have the vehicle inspected by your SUBARU dealer.

- When a malfunction exists — the rear differential oil temperature warning light is illuminating or the AWD warning light is flashing, there may be the case that all the indicators will disappear and the setting of the initial LSD torque will be cancelled (will return to the minimum torque). This, however, is not a malfunction of the driver's control center differential itself.

The driver's control center differential allows you to freely change the degree of limitation of the differential action (limited slip differential (LSD) torque) of your vehicle's center differential.

By using the center differential control switch, you can set an initial LSD torque to match the road surface conditions, driving conditions and your driving style.

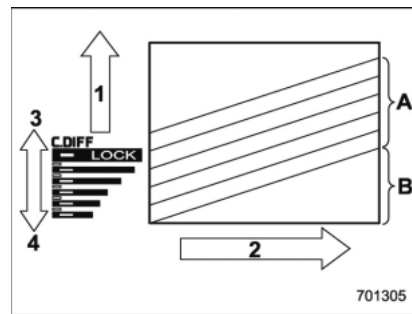

- 1) LSD torque
- 2) Traction torque
- 3) Initial LSD torque (maximum)
- 4) Initial LSD torque (minimum)
- A) Initial LSD torque (adjustable)
- B) Mechanical LSD torque

The driver's control center differential has an auto mode and a manual mode. In the auto mode, the system automatically adjusts the initial LSD torque. In the manual mode, you can change to the desired mode manually by using the center differential control switch.

NOTE

If you rapidly depress and release the accelerator pedal while driving at low speed, you may hear a knocking sound from the vicinity of the center differen-

tial and rear differential. This sound occurs because of the structure of the center differential. It does not indicate a problem.

■ To change mode of driver's control center differential

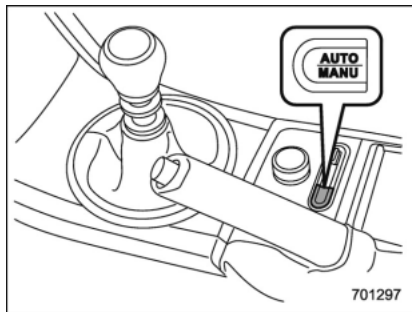

Press the "AUTO-MANU" switch on the center console to switch from auto mode to manual mode or vice versa. When you select the auto mode, the "AUTO" indicator appears. When you select the manual mode, the "AUTO" indicator disappears.

■ Auto mode

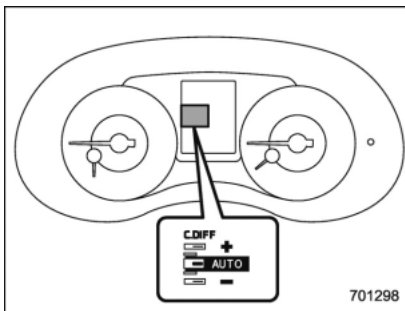

In the auto mode, the system estimates the driving and road conditions using signals from the wheel speed sensor, throttle position sensor, steering angle sensor and brake switch, etc. According to the result, it electronically and automatically controls the degree of limitation of the differential action (LSD torque) to optimize the differential action of the center differential. When the ignition switch is turned ON, the "AUTO" indicator on the combination meter appears.

The auto mode has 3 modes as follows.

Mode	Operation
AUTO [+]	This mode emphasizes traction control and strengthens the limitation of differential action that is suitable for driving on slippery roads for vehicle stability.
AUTO	This mode is suitable for most driving situations.
AUTO [-]	This mode is suitable when you seek quick response from the steering wheel and smooth driving.

▼ Mode setting method

In most situations, it is recommended that the "AUTO" mode is selected.

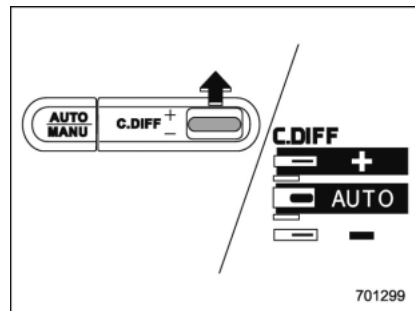

Push the control switch forward to select

the "AUTO [+]" mode. After setting the mode, "AUTO [+]" appears.

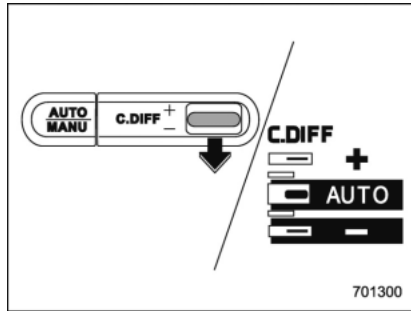

Pull the control switch rearward to select the "AUTO [-]" mode. After setting the mode, "AUTO [-]" appears.

When the "AUTO [+]" mode is selected, pull the control switch rearward to change to the "AUTO" mode. When the "AUTO [-]" mode is set, push the control switch forward to change to the "AUTO" mode.

Manual mode

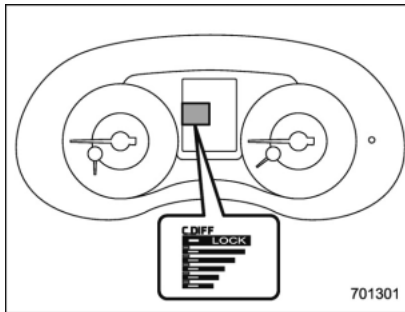

In the manual mode, you can use the center differential control switch to adjust the initial LSD torque as desired. When this mode is selected, the "AUTO" indicator disappears.

Center differential control switch and indicator

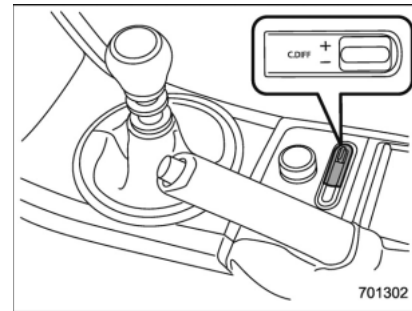

The control switch is located beside the parking brake lever. By pushing the control switch forward or pulling it rearward, it is possible to change the initial LSD torque.

The center differential indicator on the combination meter gives six levels of indication. The indicator and control switch are linked; when the switch is pushed or pulled to change the initial LSD torque, the indicator changes accordingly.

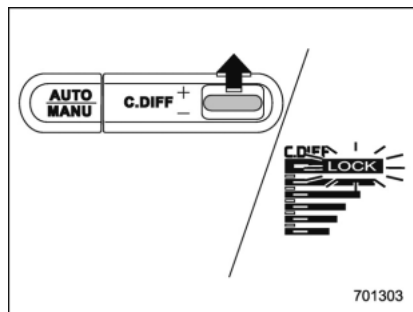

Push the switch forward to increase the initial LSD torque; when the "LOCK" indicator appears, the initial LSD torque setting is maximum. The center differential will then be almost completely locked.

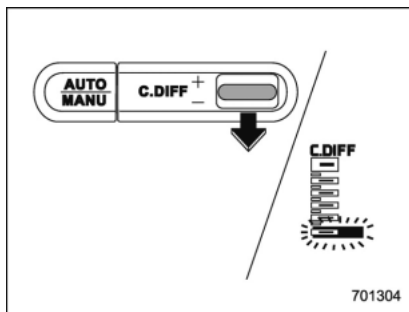

Pull the switch rearward to reduce the initial LSD torque. When the lowest position of the driver's control center differential indicator is displayed, the initial LSD torque will be minimum. Under this condition, only the Mechanical LSD torque will limit the differential action.

CAUTION

- Do not operate the control switch when a wheel slippage occurs. Wait until the wheelspin has been brought under control.
- Under any of the following conditions after setting to the manual mode, pull the center differential control switch to minimize the initial LSD torque:

- When a temporary spare tire is installed
- When your vehicle is towed
- When the vehicle is stopped with the manual mode selected

NOTE

• A higher initial LSD torque setting gives the vehicle greater traction when driving straight ahead but makes cornering more difficult. Remember this when adjusting the initial LSD torque. In general, higher initial LSD torque settings assist driving on slippery roads and lower settings for non-slippery roads. When the vehicle is stuck in snow or mud, setting the initial LSD torque to the maximum will help to free the vehicle.

- The setting of the initial LSD torque will remain even when the auto mode is selected or the ignition switch is turned to the "LOCK"/"OFF" position. However, the initial LSD torque will be minimized when the battery is disconnected and reconnected.
- During cornering or when making turns (especially when going into the garage), the rotational difference between the front and rear wheels may

cause a braking effect accompanied by vibration and noise. This does not indicate a problem. The phenomenon will disappear when setting the initial LSD torque to the minimum.

In the auto mode, it controls the initial LSD torque automatically. While in the auto mode, this phenomenon sometimes occurs depending on the driving condition, however, it does not indicate a problem.

- Use the center differential indicator only as a rough indication of the initial LSD torque.
- If you operate the center differential control switch while quickly accelerating or turning a tight corner, you may feel slight shocks. This is due to differential action by the center differential and does not indicate a problem.

■ Temporary release

When the driver stops the vehicle and pulls the parking brake lever after manually setting the initial LSD torque, the LSD torque is temporarily minimized. However the indicator on the combination meter continues to show the driver's selected initial LSD torque. When the driver releases the parking brake lever, the initial LSD torque set by the driver is restored.

Continuously variable transmission

The continuously variable transmission is electronically controlled and provides an infinite number of forward speeds and 1 reverse speed. It also has a manual mode.



WARNING

Do not shift from the "P" or "N" position into the "D" or "R" position while depressing the accelerator pedal. This may cause the vehicle to jump forward or backward.



CAUTION

- Shift into the "P" or "R" position only after the vehicle is completely stopped. Shifting while the vehicle is moving may cause damage to the transmission.
- Do not race the engine for more than 5 seconds in any position except the "N" or "P" position when the brake is applied or when chocks are used in the wheels. This may cause the transmission fluid to overheat.
- Avoid shifting from one of the

forward driving positions into the "R" position or vice versa until the vehicle has completely stopped. Such shifting may cause damage to the transmission.

- When parking the vehicle, first securely apply the parking brake and then place the select lever in the "P" position. Avoid parking for a long time with the select lever in any other position as doing so could result in a dead battery.

NOTE

- Immediately after transmission fluid is replaced, you may feel that the transmission operation is somewhat unusual. This results from invalidation of data which the on-board computer has collected and stored in memory to allow the transmission to shift at the most appropriate times for the current condition of your vehicle. Optimized shifting will be restored as the vehicle continues to be driven for a while.
- When driving a CVT model under continuous heavy load conditions such as when climbing a long, steep hill, the engine speed or the vehicle speed may

automatically be reduced. This is not a malfunction. This phenomenon results from the engine control function maintaining the cooling performance of the vehicle. The engine and vehicle speed will return to a normal speed when the engine is able to maintain the optimum cooling performance after the heavy load decreases. Driving under a heavy load must be performed with extreme care.

- The continuously variable transmission is a chain type system that provides superior transmission efficiency for maximum fuel economy. At times, depending on varying driving conditions, a chain operating sound may be heard that is characteristic of this type of system.

■ Select lever

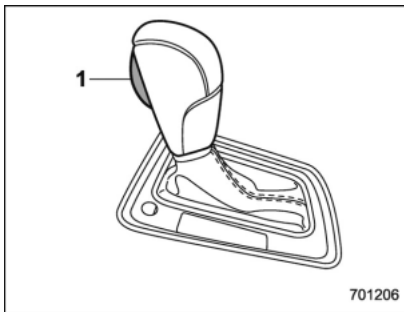

1) Select lever button

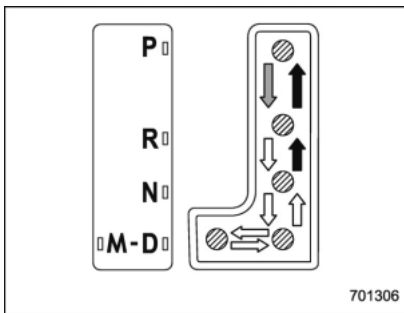

↔ : With the brake pedal depressed, shift while pressing the select lever button in.

➡ : Shift while pressing the select lever

button in.

↔ : Shift without pressing the select lever button.

The select lever has four positions, "P", "R", "N", "D" and it also has an "M" position for using the manual mode.

▼ P (Park)

This position is for parking the vehicle and starting the engine. In this position, the transmission is mechanically locked to prevent the vehicle from rolling freely.

When you park the vehicle, first apply the parking brake firmly, then shift into the "P" position. Do not hold the vehicle with only the mechanical friction of the transmission.

To shift the select lever from the "P" to any other position, you should depress the brake pedal fully then move the select lever. This prevents the vehicle from lurching when it is started.

▼ R (Reverse)

This position is for backing the vehicle. To shift from the "N" to "R" position, stop the vehicle completely then move the lever to the "R" position while pressing the select lever button in.

When the ignition switch has been turned to the "LOCK"/"OFF" position, movement

of the select lever from the “N” to “R” position is possible for a limited time period by depressing the brake pedal, and then it becomes impossible. For details, refer to “Shift lock function” 7-27.

▼ N (Neutral)

This position is for restarting a stalled engine. In this position, the transmission is neutral, meaning that the wheels and transmission are not locked. Therefore, the vehicle will roll freely, even on the slightest incline unless the parking brake or foot brake is applied.

Avoid coasting with the transmission in neutral. Engine braking has no effect in this condition.

WARNING

Do not drive the vehicle with the select lever in the “N” (neutral) position. Engine braking has no effect in this condition and the risk of an accident is consequently increased.

NOTE

If the select lever is in the “N” position when you stop the engine for parking, you may not subsequently be able to move it to the “R” and “P” positions. If this happens, turn the ignition switch to the “ON” position. You will then be able to move the select lever to the “P” position.

▼ D (Drive)

This position is for normal driving. The transmission shifts automatically and continuously into a suitable gear according to the vehicle speed and the acceleration you require. Also, while driving up and down a hill, the transmission assists and controls the driving performance and engine braking while corresponding to the road grade.

When more acceleration is required in the “D” position, depress the accelerator pedal fully to the floor and hold that position. The transmission will automatically downshift. If the Intelligent (I) mode or the Sport (S) mode has been selected, the transmission will operate like a conventional automatic transmission. When you release the pedal, the transmission will return to the original gear position.

If one of the shift paddles behind the

steering wheel is operated while driving in the “D” position, the transmission will temporarily switch to the manual mode. In this mode, you can shift into any gear position using the shift paddles. For details about the manual mode, refer to “Selection of manual mode” 7-25. Once the vehicle speed stabilizes, the transmission will switch from the manual mode back to the “D” position for normal driving.

■ Selection of manual mode

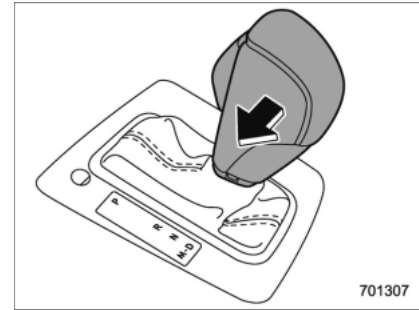

With the vehicle either moving or stationary, move the select lever from the “D” position to the “M” position to select the manual mode.

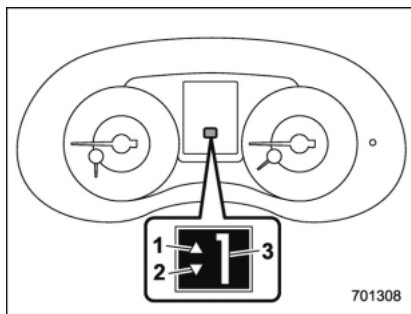

- 1) Upshift indicator
- 2) Downshift indicator
- 3) Gear position indicator

When the manual mode is selected, the gear position indicator and upshift indicator and/or downshift indicator on the combination meter appear.

The gear position indicator shows the currently selected gear in the following range.

- 1st-to-8th-gear (when the Sport Sharp (S#) mode is selected)
- 1st-to-6th-gear (in other situations)

The upshift and downshift indicators show when a gear shift is possible. When the upshift indicator “▲” appears, upshifting is possible. When the downshift indicator “▼” appears, downshifting is possible.

When both indicators appear, upshifting and downshifting are both possible. When the vehicle stops (for example, at traffic signals), the downshift indicator turns off.

Gearshifts can be performed using the shift paddle behind the steering wheel.

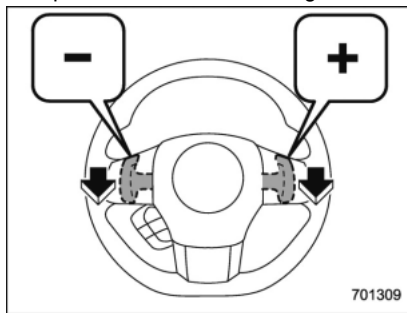

To upshift to the next higher gear position, pull the shift paddle that has “+” indicated on it. To downshift to the next lower gear position, pull the shift paddle that has “-” indicated on it.

To deselect the manual mode, return the select lever to the “D” position from the “M” position.

CAUTION

Do not place or hang anything on

the shift paddles. Doing so may result in accidental gear shifting.

NOTE

Please read the following points carefully and bear them in mind when using the manual mode.

- If you attempt to shift down when the engine speed is too high, i.e., when a downshift would push the tachometer needle beyond the red zone, beeps will be emitted to warn you that the downshift is not possible.
- If you attempt to shift up when the vehicle speed is too low, the transmission will not respond.
- You can perform a skip-shift (for example, from 4th to 2nd) by operating the shift paddle twice in rapid succession.
- The transmission automatically selects 1st gear when the vehicle stops moving.
- If the temperature of the transmission fluid becomes too high, the “AT OIL TEMP” warning light on the combination meter will illuminate. Immediately stop the vehicle in a safe location and let the engine idle until the warning light turns off.
- By selecting the Sport Sharp (S#)

mode, upshifting will not occur automatically. According to the road conditions, shift change manually so that the tachometer needle does not enter the red zone. Also, if the engine revolutions reach the specified number, the fuel supply will be cut. In this case, perform shift up operation.

■ Shift lock function

The shift lock function helps prevent the improper operation of the select lever.

- The select lever cannot be operated unless the ignition switch is turned to the "ON" position and the brake pedal is depressed.
- The select lever cannot be moved from the "P" position to any other position before the brake pedal is depressed. Depress the brake pedal first, and then operate the select lever.
- Only the "P" position allows you to turn the ignition switch from the "ACC" position to the "LOCK"/"OFF" position and remove the key from the ignition switch.
- If the ignition switch is turned to the "LOCK"/"OFF" position while the select lever is in the "N" position, the select lever may not be moved to the "P" position after a period of time. Therefore, move the select lever to the "P" position with the

brake pedal depressed soon after the ignition switch is turned to the "LOCK"/"OFF" position.

▼ Shift lock release

If the select lever cannot be operated, turn the ignition switch back to the "ON" position then move the select lever to the "P" position with the select lever button pressed and brake pedal depressed.

If the select lever does not move after performing the above procedure, perform the following steps.

● When the select lever cannot be shifted from "P" to "N":

Refer to "Shift lock release using the shift lock release button" 7-27.

● When the select lever cannot be shifted from "N" to "R", "P":

Within 60 seconds after placing the ignition switch in the "ACC" position, move the select lever to the "P" position with the select lever button pressed and brake pedal depressed.

If you must perform the above procedure, the shift lock system (or the vehicle control system) may be malfunctioning. Contact a SUBARU dealer for an inspection as soon as possible.

If the select lever does not move after

performing the above procedure, refer to "Shift lock release using the shift lock release button" 7-27.

▼ Shift lock release using the shift lock release button

Perform the following procedure to release the shift lock.

1. Apply the parking brake and stop the engine.

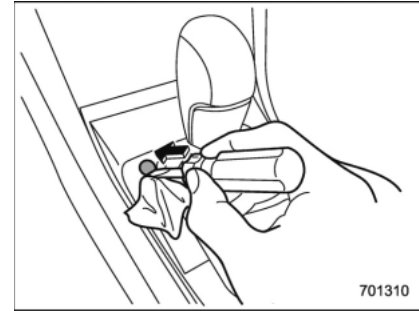

2. Wrap the tip of a flat-head screwdriver with vinyl tape or a cloth and use it to remove the shift lock cover. The shift lock release button is located under the shift lock cover.

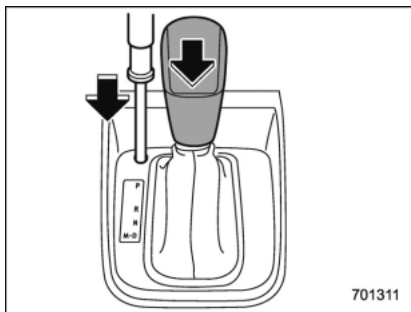

3. While depressing the brake pedal, insert a screwdriver into the hole, press the shift lock release button using a screwdriver, and then move the select lever.

If the select lever does not move after performing the above procedure, the shift lock system may be malfunctioning. Contact a SUBARU dealer for an inspection as soon as possible.

■ Driving tips

- Always apply the foot or parking brake when the vehicle is stopped in the “D” or “R” position.
- Always apply the parking brake when parking your vehicle. Do not hold the vehicle with only the mechanical friction of the transmission.

- Do not keep the vehicle in a stationary position on an uphill grade by using the “D” position. Use the brake instead.
- The engine may, on rare occasions, knock when the vehicle rapidly accelerates or rapidly pulls away from a standstill. This phenomenon does not indicate a malfunction.

SI-DRIVE (STI)

SI-DRIVE (SUBARU Intelligent Drive) works to maximize engine performance, control and efficiency.

This system consists of three modes: Intelligent (I), Sport (S), and Sport Sharp (S#). By adjusting the SI-DRIVE selector, the character of the power unit changes.

■ Intelligent (I) mode

▼ For smooth, efficient performance driving

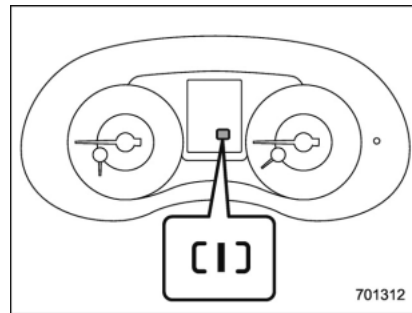

The Intelligent (I) mode provides well-balanced performance with greater fuel efficiency and smooth driveability without stress. Power delivery is moderate during acceleration for maximum fuel efficiency.

This is ideal for around-town driving and situations that do not require full power output. It provides better control in difficult driving conditions, such as slippery roads or loose surfaces, due to gentler throttle response.

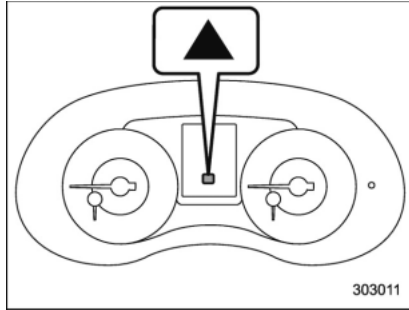

When the Intelligent (I) mode is selected, a shift-up indicator “▲” on the combination meter will blink to signal the best time to shift gears for maximum fuel efficiency.

■ Sport (S) mode

▼ For all-around performance driving

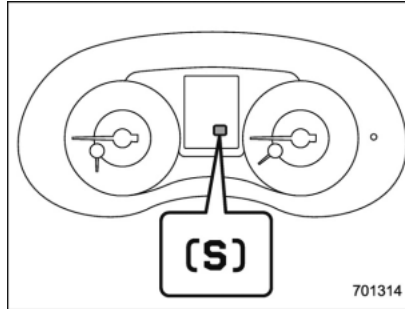

The Sport (S) mode provides the engine power desired by those who want to make the driving experience their own personal adventure.

The linear acceleration characteristic of this versatile mode is ideal for normal driving use.

■ Sport Sharp (S#) mode

▼ For maximum performance driving

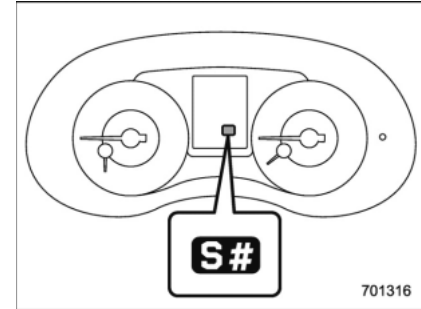

For sports-minded drivers, the Sport Sharp (S#) mode offers an exhilarating level of engine performance and control. The throttle becomes more responsive regardless of the engine speed. Delivering maximum driving enjoyment, this mode is ideal for tackling twisting roads and for merging or overtaking other vehicles on the freeway with confidence.

■ SI-DRIVE selector

When you rotate the SI-DRIVE selector to the left, the current SI-DRIVE mode changes to the Sport (S) mode. When you rotate it to the right, the mode changes to the Sport Sharp (S#) mode, and when you push it, the mode changes to the Intelligent (I) mode. After performing this operation, the switch returns to its original location.

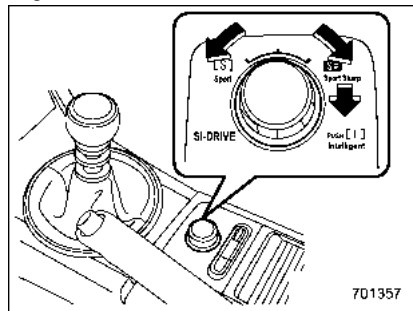

NOTE

- The next time you turn on the engine, after you turned off the engine in the Sport Sharp (S#) mode, the SI-DRIVE mode changes to the Sport (S) mode.
- The next time you turn on the engine, after you turned off the engine in the Sport (S) mode or Intelligent (I)

mode, the SI-DRIVE mode will stay in the same mode as when the engine was turned off.

- While the engine is running, if the **CHECK ENGINE** warning light/malfunction indicator light illuminates, the SI-DRIVE mode changes to the Sport (S) mode. In this case, it is not possible to change to the Sport Sharp (S#) mode or Intelligent (I) mode.
- If there is a possibility that the engine could overheat because of a temperature increase of the engine coolant, it is not possible to change to the Sport Sharp (S#) mode. While the vehicle is in the Sport Sharp (S#) mode, it changes to the Sport (S) mode when the engine coolant temperature increases.
- If any of the SI-DRIVE indicators blink, the SI-DRIVE system may be malfunctioning. Contact your SUBARU dealer.

SI-DRIVE (except STI: CVT models)

SI-DRIVE (SUBARU Intelligent Drive) works to maximize engine performance, control and efficiency.

This system consists of three modes: Intelligent (I), Sport (S), and Sport Sharp (S#). By operating the SI-DRIVE switches, the character of the power unit changes.

■ Intelligent (I) mode

- ▼ For smooth, efficient performance driving

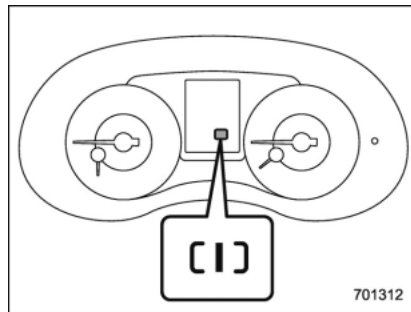

The linear acceleration characteristic of the Intelligent (I) mode is ideal for normal driving usage.

The Intelligent (I) mode provides well-balanced performance with greater fuel efficiency and smooth driveability without stress. Power delivery is moderate during acceleration for maximum fuel efficiency. This is ideal for around-town driving and situations that do not require full power output. It provides better control in difficult driving conditions, such as slippery roads or loose surfaces, due to gentler throttle response.

■ Sport (S) mode

▼ For all-around performance driving

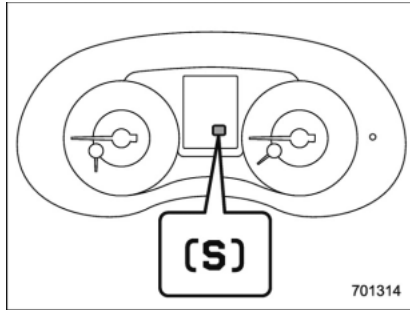

The Sport (S) mode provides the engine power desired by those who want to make the driving experience their own personal adventure.

■ Sport Sharp (S#) mode

▼ For maximum performance driving

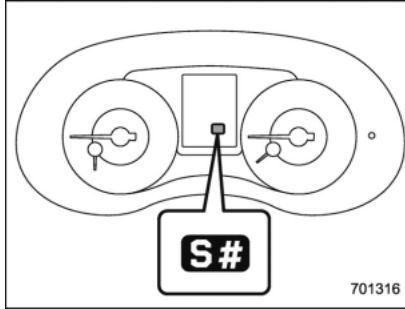

For sports-minded drivers, the Sport Sharp (S#) mode offers an exhilarating level of engine performance and control. The throttle becomes more responsive regardless of the engine speed. Delivering maximum driving enjoyment, this mode is ideal for tackling twisting roads and for merging or overtaking other vehicles on the freeway with confidence.

When you select the Sport Sharp (S#) mode while the select lever is in the "D" position, the transmission gear ratio will shift from variable speed to eight-speed. The select lever/gear position indicator display will change from "D" to the gear position.

When selecting Sport Sharp (S#) mode, the following controls will be applied.

Uphill control: Prevents unnecessary shift-up/shift-down during ascent.

Cornering control: While turning, if there is a large centrifugal force, shift-up will not occur: during re-acceleration.

Braking control: At the beginning of corners etc., heavy application of the brake pedal will cause automatic down-shift and gently re-accelerate.

Sudden acceleration return control: During acceleration, if acceleration pedal is returned suddenly (for example, at corners etc.), shift-up will not be applied.

■ SI-DRIVE switches

NOTE

If any of the SI-DRIVE indicators blink, the SI-DRIVE system may be malfunctioning. Contact your SUBARU dealer.

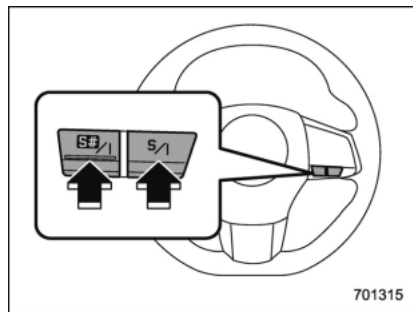

SI-DRIVE switches

To select the Intelligent (I) mode, perform either of the following procedures.

- Press the “S/I” switch when the Sport (S) mode is selected
- Press the “S#/I” switch when the Sport Sharp (S#) mode is selected

To select the Sport (S) mode, press the “S/I” switch when any mode other than Sport (S) mode is selected.

To select the Sport Sharp (S#) mode, press the “S#/I” switch when any mode

other than Sport Sharp (S#) mode is selected.

NOTE

- The next time you turn on the engine, after you turned off the engine in the Sport (S) mode or Sport Sharp (S#) mode, the SI-DRIVE mode changes to the Intelligent (I) mode.

- While the engine is running, if the CHECK ENGINE warning light/malfunction indicator light illuminates, the SI-DRIVE mode changes to the Sport (S) mode. In this case, it is not possible to change to another mode.

- If there is a possibility that the engine could overheat because of a temperature increase of the engine coolant, it is not possible to change to the Sport Sharp (S#) mode. While the vehicle is in the Sport Sharp (S#) mode, it changes to the Sport (S) mode when the engine coolant temperature increases.

Limited slip differential (LSD) (STI)

The LSD provides optimum distribution of power according to the difference in revolutions between the right and left wheels that may be caused by certain driving conditions, thereby improving driving stability on snow-covered, muddy or other slippery roads or when high speed driving.

CAUTION

- Never start the engine while a tire on one side is jacked up, as the vehicle may move.
- If one tire is spinning in mud, avoid continued spinning at high speed as this could adversely affect the LSD.
- If you use a temporary spare tire to replace a flat tire, be sure to use the original temporary spare tire stored in the vehicle. Using other sizes will adversely affect the LSD.

Power steering

■ STI

The vehicle is equipped with a hydraulic power steering system. The power steering system operates only when the engine is running.

If you lose power steering assist because the engine stops or the system fails to function, you can steer but it will take much more effort.

CAUTION

Do not hold the steering wheel at the fully locked position left or right for more than 5 seconds. This may damage the power steering pump.

NOTE

Right after the engine has been started and before it has warmed up, you may hear a noise coming from areas adjacent to the power steering pump which is located at the right-front area of the engine compartment. This noise is normal. It does not indicate power steering system trouble.

■ Except STI

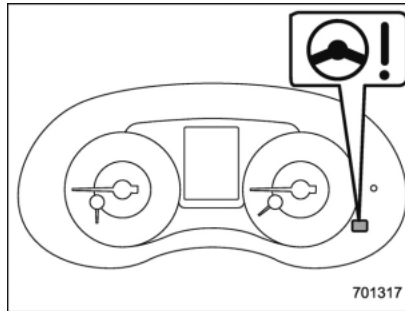

Power steering warning light

The vehicle is equipped with an electric power steering system. The power steering system operates only while the engine is running. When the ignition switch is turned to the "ON" position, the power steering warning light on the combination meter illuminates to inform the driver that the warning system is functioning properly. Then, if the engine started, the warning light turns off to inform the driver that the steering power assist is operational.

CAUTION

While the power steering warning light is illuminated, there may be more resistance when the steering

wheel is operated. Drive carefully to the nearest SUBARU dealer and have the vehicle inspected immediately.

NOTE

If the steering wheel is operated in the following ways, the power steering control system may temporarily limit the power assist in order to prevent the system components, such as the control computer and drive motor, from overheating.

- The steering wheel is operated frequently and turned sharply while the vehicle is maneuvered at extremely low speeds, such as while frequently turning the steering wheel during parallel parking.
- The steering wheel remains in the fully turned position for a long period of time.

At this time, there will be more resistance when steering. However this is not a malfunction. Normal steering force will be restored after the steering wheel is not operated for a while and the power steering control system has an opportunity to cool down. However, if the power steering is operated in a non-standard way which causes power

assist limitation to occur too frequently, this may result in a malfunction of the power steering control system.

Braking

■ Braking tips



WARNING

Never rest your foot on the brake pedal while driving. This can cause dangerous overheating of the brakes and needless wear on the brake pads and linings.

▼ When the brakes get wet

When driving in rain or after washing the vehicle, the brakes may get wet. As a result, brake stopping distance will be longer. To dry the brakes, drive the vehicle at a safe speed while lightly depressing the brake pedal to heat up the brakes.

▼ Use of engine braking

Remember to make use of engine braking in addition to foot braking. When descending a grade, if only the foot brake is used, the brakes may start working improperly because of brake fluid overheating, caused by overheated brake pads. To help prevent this, shift into a lower gear to get stronger engine braking.

▼ Braking when a tire is punctured

Do not depress the brake pedal suddenly when a tire is punctured. This could cause

a loss of control of the vehicle. Keep driving straight ahead while gradually reducing speed. Then slowly pull off the road to a safe place.

■ Brake system

▼ Two separate circuits

Your vehicle has two separate circuit brake systems. Each circuit works diagonally across the vehicle. If one circuit of the brake system should fail, the other half of the system still works. If one circuit fails, the brake pedal will go down much closer to the floor than usual and you will need to press it down much harder. And a much longer distance will be needed to stop the vehicle.

▼ Brake booster

The brake booster uses engine manifold vacuum to assist braking force. Do not turn off the engine while driving because that will turn off the brake booster, resulting in poor braking power.

The brakes will continue to work even when the brake booster completely stops functioning. If this happens, however, you will have to depress the pedal much harder than normal and the braking distance will increase.

▼ Brake assist system

⚠ WARNING

Do not be overconfident about the brake assist. It is not a system that brings more braking ability to the vehicle beyond its braking capability. Always use the utmost care when driving regarding vehicle speed and safe distance.

⚠ CAUTION

When you need to brake suddenly, continue depressing the brake pedal strongly to obtain the effect of the brake assist.

Brake assist is a driver assistance system. It assists the brake power when the driver cannot depress the brake pedal strongly and the brake power is insufficient.

Brake assist generates the brake power according to the speed at which the driver depresses the brake pedal.

NOTE

When you depress the brake pedal strongly or suddenly, the following phenomena occur. However, even though these occur, they do not indi-

cate any malfunctions, and the brake assist system is operating properly.

- You might feel that the brake pedal is applied by lighter force and generates a greater braking force.
- You might hear an ABS operating noise from the engine compartment.

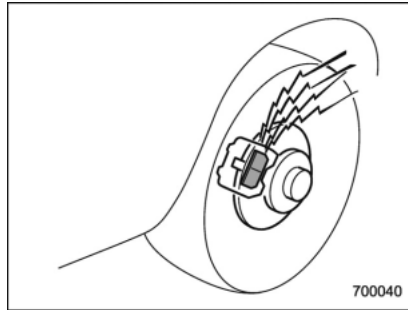
■ Disc brake pad wear warning indicators

The disc brake pad wear warning indicators on the disc brakes give a warning noise when the brake pads are worn.

If a squeaking or scraping noise is heard from the disc brakes while braking, immediately have your vehicle checked by your SUBARU dealer.

ABS (Anti-lock Brake System)

The ABS system prevents the lock-up of wheels which may occur during sudden braking or braking on slippery road surfaces. This helps prevent the loss of steering control and directional stability caused by wheel lock-up.

When the ABS system is operating, you may hear a chattering noise or feel a slight vibration in the brake pedal. This is normal when the ABS operates.

The ABS system will not operate when the vehicle speed is below approximately 6 mph (10 km/h).

⚠ WARNING

Always use the utmost care in driving – overconfidence because you are driving a vehicle with the ABS system could easily lead to a serious accident.

⚠ CAUTION

- The ABS system does not always decrease stopping distance. You should always maintain a safe

following distance from other vehicles.

- **When driving on badly surfaced roads, gravel roads, icy roads, or over deep newly fallen snow, stopping distances may be longer for a vehicle with the ABS system than one without. When driving under these conditions, therefore, reduce your speed and leave ample distance from other vehicles.**
- **When you feel the ABS system operating, you should maintain constant brake pedal pressure. Do not pump the brake pedal since doing so may defeat the operation of the ABS system.**

■ ABS system self-check

Just after the vehicle is started, you may feel on the brake pedal a vibration similar to when the ABS operates, and you may also hear the sound of the ABS working from the engine compartment. This is caused by an automatic functional test of the ABS system being carried out and does not indicate any abnormal condition.

■ ABS warning light

Refer to "ABS warning light" 3-20.

Electronic Brake Force Distribution (EBD) system

The EBD system maximizes the effectiveness of the brakes by allowing the rear brakes to supply a greater proportion of the braking force. It functions by adjusting the distribution of braking force to the rear wheels in accordance with the vehicle's loading condition and speed.

The EBD system is an integral part of the ABS system and uses some of the ABS system's components to perform its function of optimizing the distribution of braking force. If any of the ABS components used by the EBD system malfunction, the EBD system also stops working.

When the EBD system is operating, you may hear a chattering noise or feel a slight vibration in the brake pedal. This is normal and does not indicate a malfunction.

■ Steps to take if EBD system malfunctions

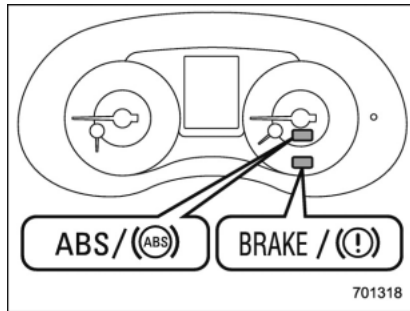

Brake and ABS warning light

If a malfunction occurs in the EBD system, the system stops working and the brake system warning light and ABS warning light illuminate simultaneously.

The EBD system may be malfunctioning if the brake system warning light and ABS warning light illuminate simultaneously during driving.

Even if the EBD system malfunctions, the conventional braking system will still function. However, the rear wheels will be more prone to locking when the brakes are applied harder than usual and the vehicle's motion may therefore become somewhat harder to control.

If the brake system warning light and ABS warning light illuminate simultaneously, take the following steps.

1. Stop the vehicle in the nearest safe, flat location.
2. Shut down the engine, apply the parking brake, and then restart it.
3. Release the parking brake. If both warning lights turn off, the EBD system may be malfunctioning. Drive carefully to the nearest SUBARU dealer and have the system inspected.
4. If both warning lights illuminate again and remain illuminated after the engine has been restarted, shut down the engine again, apply the parking brake, and check the brake fluid level. Refer to "Brake fluid" 11-24.
5. If the brake fluid level is not below the "MIN" mark, the EBD system may be malfunctioning. Drive carefully to the nearest SUBARU dealer and have the system inspected.
6. If the brake fluid level is below the "MIN" mark, DO NOT drive the vehicle. Instead, have the vehicle towed to the nearest SUBARU dealer for repair.



WARNING

- Driving with the brake system

warning light illuminated is dangerous. This indicates your brake system may not be working properly. If the light remains illuminated, have the brakes inspected by a SUBARU dealer immediately.

- If at all in doubt about whether the brakes are operating properly, do not drive the vehicle. Have your vehicle towed to the nearest SUBARU dealer for repair.

Vehicle Dynamics Control system

WARNING

Always use the utmost care in driving – overconfidence because you are driving a vehicle with the Vehicle Dynamics Control system could easily lead to a serious accident.

CAUTION

- Even if your vehicle is equipped with Vehicle Dynamics Control system, winter tires should be used when driving on snow-covered or icy roads; in addition, vehicle speed should be reduced considerably. Simply having a Vehicle Dynamics Control system does not guarantee that the vehicle will be able to avoid accidents in any situation.
- Activation of the Vehicle Dynamics Control system is an indication that the road being travelled on has a slippery surface; since having Vehicle Dy-

namics Control is no guarantee that full vehicle control will be maintained at all times and under all conditions, its activation should be seen as a sign that the speed of the vehicle should be reduced considerably.

- Whenever suspension components, steering components, or an axle are removed from a vehicle, have an inspection of that system performed by an authorized SUBARU dealer.
- The following precautions should be observed in order to ensure that the Vehicle Dynamics Control system is operating properly:
 - All four wheels should be fitted with tires of the same size, type, and brand. Furthermore, the amount of wear should be the same for all four tires.
 - Keep the tire pressure at the proper level as shown on the vehicle placard attached to the driver's side door pillar.
 - Use only the specified temporary spare tire to replace a flat tire. With a temporary spare tire, the effectiveness

of the Vehicle Dynamics Control system is reduced and this should be taken into account when driving the vehicle in such a condition.

- If non-matching tires are used, the Vehicle Dynamics Control system may not operate correctly.
- The Vehicle Dynamics Control system helps prevent unstable vehicle motion such as skidding using control of the brakes and engine power. Do not turn off the Vehicle Dynamics Control system unless it is absolutely necessary. If you must turn off the Vehicle Dynamics Control system, drive very carefully according to the road surface condition.

In the event of wheelspin and/or skidding on a slippery road surface and/or during cornering and/or an evasive maneuver, the Vehicle Dynamics Control system adjusts the engine's output and the wheels' respective braking forces to help maintain traction and directional control.

• Traction Control Function

The traction control function is designed to prevent spinning of the driving wheels on

slippery road surfaces, thereby helping to maintain traction and directional control. Activation of this function is shown by flashing the Vehicle Dynamics Control operation indicator light.

● Skid Suppression Function

The skid suppression function is designed to help maintain directional stability by suppressing the wheels' tendency to slide sideways during steering operations. Activation of this function is shown by flashing of the Vehicle Dynamics Control operation indicator light.

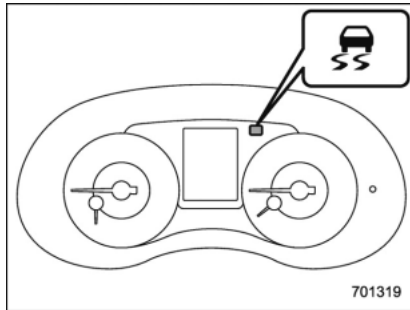

Vehicle Dynamics Control operation indicator light

NOTE

- The Vehicle Dynamics Control system may be considered normal when

the following conditions occur.

- Slight twitching of the brake pedal is felt.
- The vehicle or steering wheel shakes to a small degree.
- An operating sound from the engine compartment is heard briefly when starting the engine and when driving off after starting the engine.
- The brake pedal seems to jolt when driving off after starting the engine.

- In the circumstances shown in the following list, the vehicle may be less stable than it feels to the driver. The Vehicle Dynamics Control System may therefore operate. Such operation does not indicate a system malfunction.

- on gravel-covered or rutted roads
- on unfinished roads
- when the vehicle is fitted with snow tires or winter tires
- Activation of the Vehicle Dynamics Control system will cause operation of the steering wheel to feel slightly different compared to that for normal conditions.

- It is always important to reduce speed when approaching a corner, even if your vehicle is equipped with

the Vehicle Dynamics Control system.

- Always turn off the engine before replacing a tire. Failure to do so may render the Vehicle Dynamics Control system unable to operate correctly.

■ Vehicle Dynamics Control system monitor

Refer to “Vehicle Dynamics Control warning light/Vehicle Dynamics Control operation indicator light” [Ⓐ]3-23 and “Vehicle Dynamics Control OFF indicator light/Traction mode indicator light” [Ⓐ]3-25.

■ Vehicle Dynamics Control OFF switch

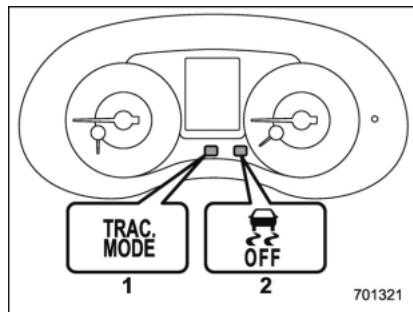

- 1) Traction mode indicator light
- 2) Vehicle Dynamics Control OFF indicator light

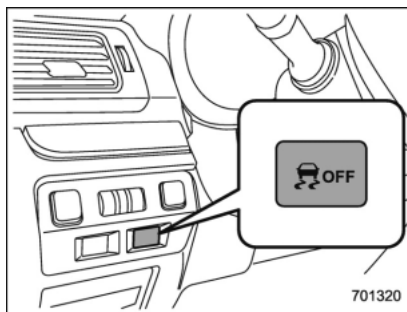

Vehicle Dynamics Control OFF switch

When the switch is pressed briefly or for more than approximately 2 seconds during engine operation, the mode of the Vehicle Dynamics Control system will be changed.

▼ Vehicle Dynamics Control mode

When the ignition switch is on, this mode is selected.

This mode enables all controls for ABS, the Traction Control System, and the Vehicle Dynamics Control system. Select this mode for most driving situations.

When this mode is selected, both indicator lights on the combination meter turn off.

▼ Traction mode

This mode restricts the functions of the Traction Control System and Vehicle Dynamics Control system and thus delays utilizing their functions as a reaction to vehicle behavior in comparison with the Vehicle Dynamics Control mode. This mode should be used in driving situations where the vehicle dynamic performance will improve without decreasing engine torque control.

When the switch is pressed briefly during engine operation, the traction mode indicator light and the Vehicle Dynamics Control OFF indicator light on the combination meter illuminate. When the switch is pressed again to reactivate the Vehicle Dynamics Control system, the traction mode indicator light and the Vehicle Dynamics Control OFF indicator light turn off.

▼ Vehicle Dynamics Control OFF mode

This mode allows only the ABS control. This mode should be used in an emergency situation such as getting out of snow or mud.

When the switch is pressed for more than approximately 2 seconds during engine operation, the Vehicle Dynamics Control OFF indicator light on the combination

meter illuminates. When the switch is pressed again to reactivate the Vehicle Dynamics Control system, the Vehicle Dynamics Control OFF indicator light turns off.

NOTE

- The Vehicle Dynamics Control system will be activated automatically when the engine is started.
- If the switch is held down for 30 seconds or longer, the Vehicle Dynamics Control OFF indicator light turns off, the Vehicle Dynamics Control system is activated, and the system ignores any further pressing of the switch. To make the switch usable again, turn the ignition switch to the "LOCK"/"OFF" position and restart the engine.
- When the Vehicle Dynamics Control OFF mode is selected, the vehicle's running performance is comparable with that of a vehicle that does not have a Vehicle Dynamics Control system. Do not deactivate the Vehicle Dynamics Control system except when absolutely necessary.
- Even when the Vehicle Dynamics Control OFF mode is selected, components of the brake control system may still activate. When the brake control system is activated, the Vehicle Dy-

namics Control operation indicator light illuminates.

Tire pressure monitoring system (TPMS) (U.S.-spec. models)

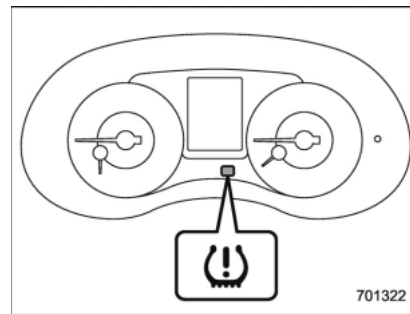

Low tire pressure warning light

The tire pressure monitoring system provides the driver with a warning message by sending a signal from a sensor that is installed in each wheel when tire pressure is severely low.

The tire pressure monitoring system will activate only when the vehicle is driven at speeds above 20 mph (32 km/h). Also, this system may not react immediately to a sudden drop in tire pressure (for example, a blow-out caused by running over a sharp object).

 **WARNING**

If the low tire pressure warning light illuminates while driving, never brake suddenly and keep driving straight ahead while gradually reducing speed. Then slowly pull off the road to a safe place. Otherwise an accident involving serious vehicle damage and serious personal injury could occur.

Check the pressure for all four tires and adjust the pressure to the COLD tire pressure shown on the tire placard on the door pillar on the driver's side.

Even when the vehicle is driven a very short distance, the tires get warm and their pressures increase accordingly. Be sure to let the tires cool thoroughly before adjusting their pressures to the standard values shown on the tire placard. Refer to "Tires and wheels"  11-30. The tire pressure monitoring system does not function when the vehicle is stationary. After adjusting the tire pressures, increase the vehicle speed to at least 20 mph (32 km/h) to start the TPMS re-checking of the tire inflation pressures. If the tire pressures are now above the severe

low pressure threshold, the low tire pressure warning light should turn off a few minutes later.

If this light still illuminates while driving after adjusting the tire pressure, a tire may have significant damage and a fast leak that causes the tire to lose air rapidly. If you have a flat tire, replace it with a spare tire as soon as possible.

When a spare tire is mounted or a wheel rim is replaced without the original pressure sensor/transmitter being transferred, the low tire pressure warning light will illuminate steadily after blinking for approximately one minute. This indicates the TPMS is unable to monitor all four road wheels. Contact your SUBARU dealer as soon as possible for tire and sensor replacement and/or system resetting.

Do not inject any tire liquid or aerosol tire sealant into the tires, as this may cause a malfunction of the tire pressure sensors. If the light illuminates steadily after blinking for approximately one minute, promptly contact a SUBARU dealer to have the system inspected.

 **CAUTION**

- Do not place metal film or any metal parts in the trunk. This may cause poor reception of the signals from the tire pressure sensors, and the tire pressure monitoring system will not function properly.
- FCC WARNING
Changes or modifications not expressly approved by the party responsible for compliance could void the user's authority to operate the equipment.

NOTE

This device complies with part 15 of the FCC Rules and RSS-Gen of IC Rules. Operation is subject to the following two conditions: (1) This device may not cause harmful interference, and (2) this device must accept any interference received, including interference that may cause undesired operation.

Parking your vehicle

■ Parking brake

To set the parking brake, depress the brake pedal firmly and hold it down until the parking brake lever is fully pulled up.

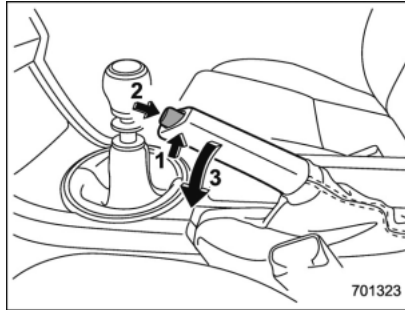

To release the parking brake, perform the following procedure.

1. Pull the lever up slightly.
2. Press the release button.
3. Lower the lever while keeping the button pressed.

When the parking brake is set while the engine is running, the parking brake warning light illuminates. After starting the vehicle, be sure that the warning light has turned off before the vehicle is driven. Refer to "Parking brake warning" 3-20.

⚠ CAUTION

Never drive while the parking brake is set because this will cause unnecessary wear on the brake linings. Before starting to drive, always make sure that the parking brake has been fully released.

■ Parking tips

When parking your vehicle, always perform the following items.

- Apply the parking brake firmly.
- For MT models, put the shift lever in the "1" (1st) for upgrade or "R" (Reverse) for a downgrade.
- For CVT models, put the select lever in the "P" (Park) position.

Never rely on the mechanical friction of the transmission alone to hold the vehicle.

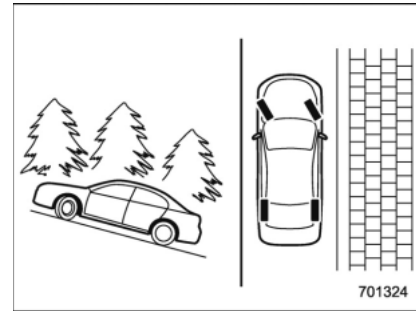

When parking on a hill, always turn the steering wheel. When the vehicle is headed up the hill, the front wheels should be turned away from the curb.

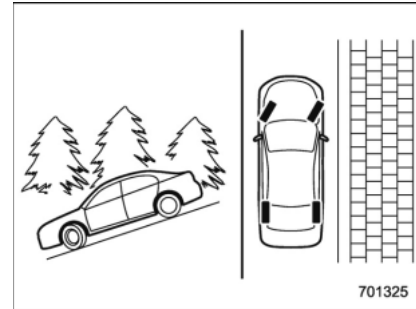

When facing downhill, the front wheels should be turned into the curb.

 **WARNING**

- Never leave unattended children or pets in the vehicle. They could accidentally injure themselves or others through inadvertent operation of the vehicle. Also, on hot or sunny days, the temperature in a closed vehicle could quickly become high enough to cause severe or possibly fatal injuries to people.
- Do not park the vehicle over flammable materials such as dry grass, waste paper or rags, as they may burn easily if they come near hot engine or exhaust system parts.
- Be sure to stop the engine if you take a nap in the vehicle. If engine exhaust gas enters the passenger compartment, occupants in the vehicle could die from carbon monoxide (CO) contained in the exhaust gas.

 **CAUTION**

If your vehicle has a front under-spoiler and rear underspoiler (both optional), pay attention to blocks

and other obstructions on the ground when parking. The under-spoilers could be damaged by contact with them.

Hill start assist system

 **CAUTION**

The Hill start assist system is a device only for helping the driver to START the vehicle on an uphill grade. To prevent accidents when the vehicle is parked on a slope, be sure to firmly set the parking brake. When setting the parking brake, make sure that the vehicle remains stationary when the clutch pedal (MT models) and brake pedal (both MT and CVT models) are released.

The Hill start assist system is a device to make the following vehicle operations easier.

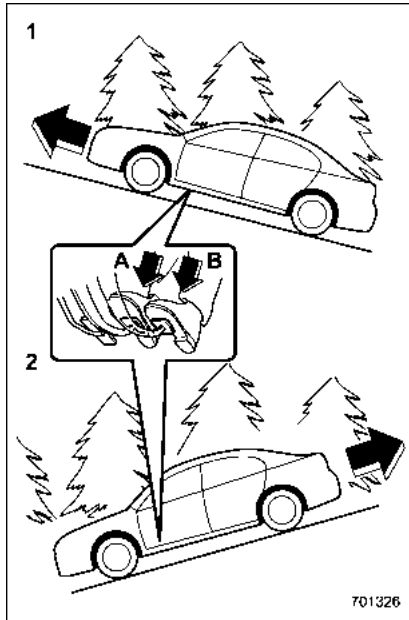

- 1) Starting forward facing uphill
 - 2) Starting backward facing downhill
- A) Brake pedal (both MT models and CVT models)
 - B) Clutch pedal (MT models only)

In both these cases, the Hill start assist system operates under the following con-

ditions.

- when the clutch pedal is depressed while the brake pedal is also depressed (MT models)
- when the vehicle has stopped with the brake pedal depressed (CVT models)

Braking power is maintained temporarily (for approximately 2 seconds) by the Hill start assist system after the brake pedal is released. The driver is therefore able to start the vehicle in the same way as on a level grade, just using the clutch pedal (MT models only) and accelerator pedal (all models).

If the braking power of the Hill start assist system is insufficient after the brake pedal is released, apply more braking power by depressing the brake pedal again.

The Hill start assist system may not operate on slight grades. Also, the Hill start assist system does not operate in the following cases.

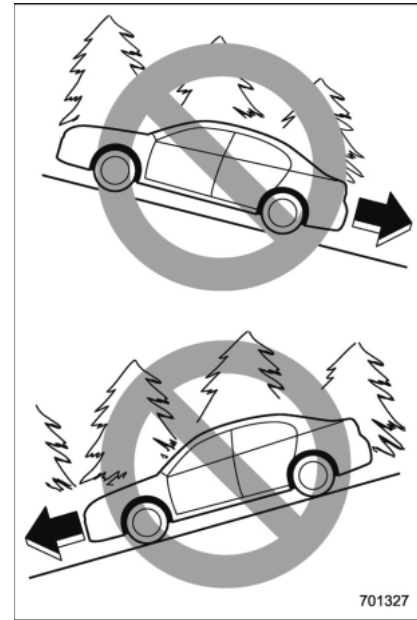

- when starting backward facing uphill
- when starting forward facing downhill
- while the parking brake is applied
- while the ignition switch is in the "ACC" or "LOCK"/"OFF" position
- while the Hill start assist warning light/

Hill start assist OFF indicator light is illuminated

When using the Hill start assist system, a braking effect may be felt even after the brake pedal has been released. However, this braking effect should disappear once the clutch pedal is released.

NOTE

A slight jolt may be felt when the vehicle begins to move forward after being reversed.

■ To activate/deactivate the Hill start assist system

CAUTION

While the Hill start assist system is deactivated, when starting on an uphill grade, braking power is not maintained if the brake pedal is released. Start on an uphill grade by using the parking brake.

You can activate/deactivate the Hill start assist system according to the following procedure.

NOTE

If you make an error when performing any steps in the following procedure,

place the ignition switch in the “LOCK”/“OFF” position once and then start over again.

▼ To deactivate

1. Park your vehicle in a flat and safe location and apply the parking brake.
2. Turn the ignition switch to the “LOCK”/“OFF” position.
3. Restart the engine.

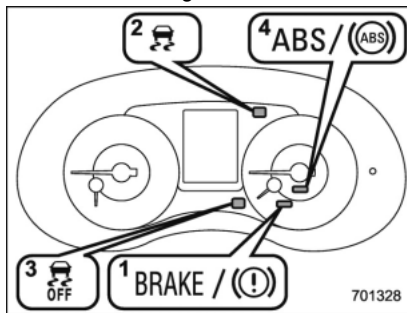

4. Confirm the following items.
 - (1) The Brake system warning light illuminates.
 - (2) The Vehicle Dynamics Control warning light turns off.
 - (3) The Vehicle Dynamics Control OFF indicator light turns off.
 - (4) The ABS warning light turns off.

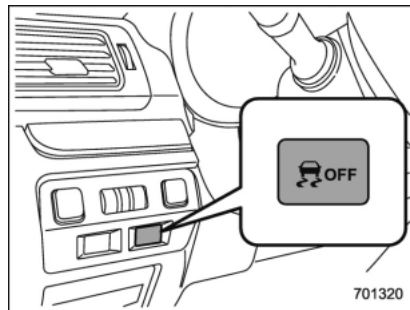

Vehicle Dynamics Control OFF switch

5. Press the Vehicle Dynamics Control OFF switch and hold it until the Vehicle Dynamics Control OFF indicator light “OFF” on the combination meter illuminates for several seconds and then turns off.
6. Within 5 seconds after the Vehicle Dynamics Control OFF indicator light turns off, release the Vehicle Dynamics Control OFF switch.

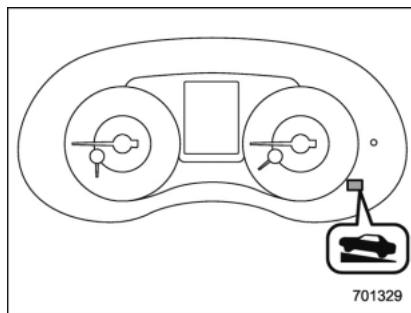

Hill start assist OFF indicator light

7. Within 2 seconds after releasing the Vehicle Dynamics Control OFF switch, press the Vehicle Dynamics Control OFF switch once again. Then the Hill start assist OFF indicator light illuminates.
8. Turn the ignition switch to the "LOCK"/"OFF" position. The hill start assist system has now been deactivated.

NOTE

While the Hill start assist system is deactivated, the Hill start assist OFF indicator light illuminates continuously.

▼ To activate

When the procedure to deactivate the Hill start assist system is performed again, the

system is activated. When the Hill start assist system is activated, the Hill start assist OFF indicator light turns off.

■ Hill start assist warning light/ Hill start assist OFF indicator light

Refer to "Hill start assist warning light/Hill start assist OFF indicator light" 3-22.

Cruise control

Cruise control enables you to maintain a constant vehicle speed without holding your foot on the accelerator pedal and it is operative when the vehicle speed is 25 mph (40 km/h) or more.



WARNING

Do not use the cruise control under any of the following conditions. These may cause loss of vehicle control.

- driving up or down a steep grade
- driving on slippery or winding roads
- driving in heavy traffic

NOTE

- On uphill and downhill slopes, depending on the degree of the slope and the load of the vehicle, there may be cases when a constant speed cannot be guaranteed.
- If the cruise control indicator does not appear even after pressing the cruise control main button, it is possible that there is a malfunction in the system. We recommend that you contact your SUBARU dealer for an in-

spection.

- Make sure the cruise control system is turned off when the cruise control is not in use to avoid unintentionally setting the cruise control.

■ To set cruise control

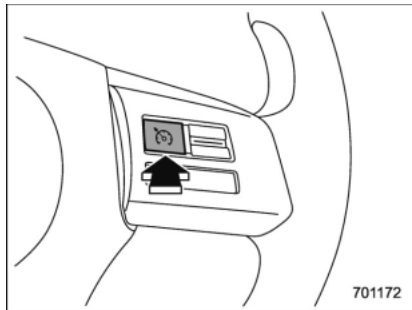

Cruise control main button

1. Press the cruise control main button.

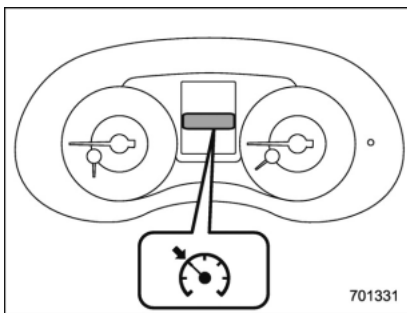

Cruise control indicator

The cruise control indicator on the combination meter will appear.

2. Depress the accelerator pedal until the vehicle reaches the desired speed.

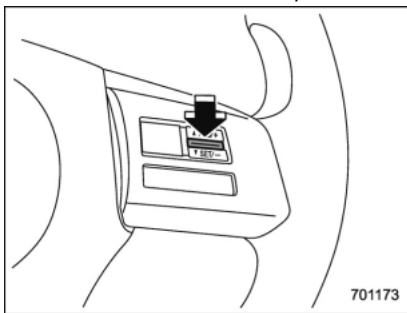

3. Press the "RES/SET" switch to the

"SET" side and release it. Then release the accelerator pedal.

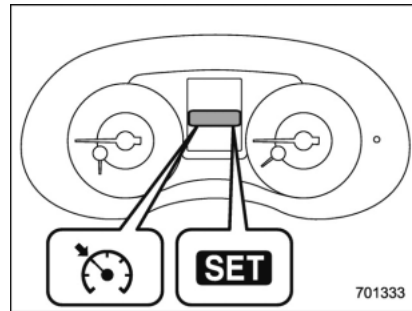

Cruise control set indicator

At this time, the cruise control set indicator appears in the combination meter.

The vehicle will maintain the desired speed.

Vehicle speed can be temporarily increased while driving with the cruise control activated. Simply depress the accelerator pedal to accelerate the vehicle. When the accelerator pedal is released, the vehicle will return to and maintain the previous cruising speed.

NOTE

For CVT models, when you set the desired speed while the Sport Sharp

(S#) mode is selected, the select lever/gear position indicator will change from the current gear position indication to the “D” indication.

■ To temporarily cancel the cruise control

The cruise control can be temporarily canceled in the following ways.

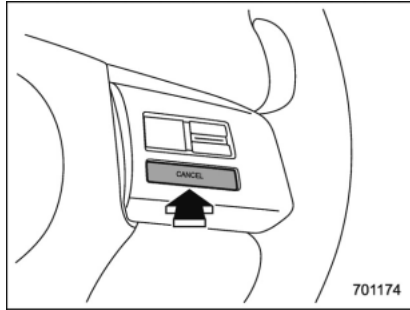

- Press the “CANCEL” button.
- Depress the brake pedal.
- Depress the clutch pedal (MT models only).

WARNING

For CVT models, you can cancel the cruise control by shifting the select lever into the “N” position. However,

do not shift the lever into the “N” position while driving except in case of emergency. If the select lever is shifted into the “N” position, the engine brake will no longer work. This could result in an accident.

The cruise control set indicator in the combination meter disappears when the cruise control is canceled.

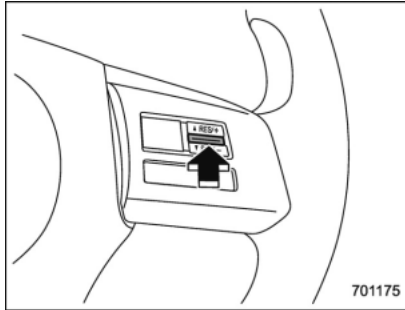

To resume the cruise control after it has been temporarily canceled and with vehicle speed of approximately 20 mph (32 km/h) or more, press the “RES/SET” switch to the “RES” side to return to the original cruising speed automatically.

The cruise control set indicator in the combination meter will automatically appear at this time.

■ To turn off the cruise control

There are two ways to turn off the cruise control:

- Press the cruise control main button again.
- Turn the ignition switch to the “ACC” or “LOCK”/“OFF” position (but only when the vehicle is completely stopped).

■ To change the cruising speed

▼ To increase the speed (by the “RES/SET” switch)

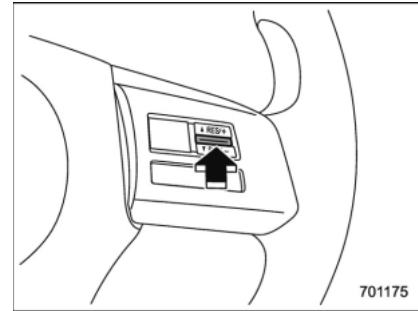

Press the “RES/SET” switch to the “RES” side and hold it until the vehicle reaches the desired speed. Then, release the switch. The vehicle speed at that moment will be memorized and treated as the new set speed.

U.S.-spec. models

The set speed can be increased 1 mph (1.6 km/h) each time by pressing the “RES/SET” switch to the “RES” side quickly.

Except U.S.-spec. models

The set speed can be increased 1 km/h each time by pressing the “RES/SET” switch to the “RES” side quickly.

▼ To increase the speed (by accelerator pedal)

1. Depress the accelerator pedal to accelerate the vehicle to the desired speed.
2. Press the “RES/SET” switch to the “SET” side once. Now the desired speed is set and the vehicle will keep running at that speed without depressing the accelerator pedal.

NOTE

CVT models:

- If you depress the accelerator pedal while the Sport Sharp (S#) mode is selected, the select lever/gear position indicator may change from the “D” indication to the current gear position indication.
- If you depress the accelerator pedal fully while the Intelligent (I) mode or the

Sport (S) mode is selected, the transmission will operate like a conventional automatic transmission.

▼ To decrease the speed (by the “RES/SET” switch)

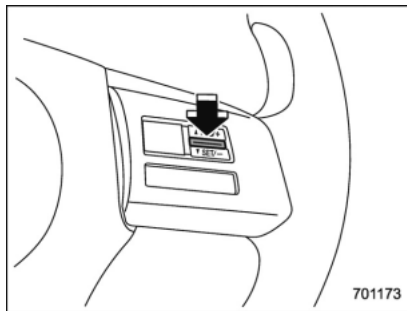

Press the “RES/SET” switch to the “SET” side and hold it until the vehicle reaches the desired speed. Then, release the switch. The vehicle speed at that moment will be memorized and treated as the new set speed.

U.S.-spec. models

The set speed can be lowered 1 mph (1.6 km/h) each time by pressing the “RES/SET” switch to the “SET” side quickly.

Except U.S.-spec. models

The set speed can be lowered 1 km/h

each time by pressing the “RES/SET” switch to the “SET” side quickly.

▼ To decrease the speed (by brake pedal)

1. Depress the brake pedal to release cruise control temporarily.
2. When the speed decreases to the desired speed, press the “RES/SET” switch to the “SET” side once. Now the desired speed is set and the vehicle will keep running at that speed without depressing the accelerator pedal.

■ Cruise control indicator

Refer to “Cruise control indicator” 3-32.

■ Cruise control set indicator

Refer to “Cruise control set indicator” 3-32.

New vehicle break-in driving – the first 1,000 miles (1,600 km)	8-2	Driving on snowy and icy roads	8-8
Fuel economy hints	8-2	Corrosion protection	8-9
Engine exhaust gas (carbon monoxide)	8-2	Snow tires	8-9
Catalytic converter	8-3	Tire chains	8-10
Periodic inspections	8-4	Rocking the vehicle	8-10
Driving in foreign countries	8-4	Loading your vehicle	8-10
Driving tips for AWD models	8-5	Vehicle capacity weight	8-11
Driving precaution	8-6	GVWR and GAWR (Gross Vehicle Weight Rating and Gross Axle Weight Rating)	8-12
Winter driving	8-6	Trailer towing	8-12
Operation during cold weather	8-6		

New vehicle break-in driving – the first 1,000 miles (1,600 km)

The performance and long life of your vehicle are dependent on how you handle and care for your vehicle while it is new. Follow these instructions during the first 1,000 miles (1,600 km):

- Do not race the engine. And do not allow engine speed to exceed 4,000 rpm except in an emergency.
- Do not drive at one constant engine or vehicle speed for a long time, either fast or slow.
- Avoid starting suddenly and rapid acceleration, except in an emergency.
- Avoid hard braking, except in an emergency.

The same break-in procedures should be applied to an overhauled engine, newly mounted engine or when brake pads or brake linings are replaced with new ones.

Fuel economy hints

The following suggestions will help to save fuel.

- Select the proper gear position for the speed and road conditions.
- Avoid sudden acceleration or deceleration. Always accelerate gently until you reach the desired speed. Then try to maintain that speed for as long as possible.
- Do not pump the accelerator and avoid racing the engine.
- Avoid unnecessary engine idling.
- Keep the engine properly tuned.
- Keep the tires inflated to the correct pressure shown on the tire placard, which is located under the door latch on the driver's side. Low pressure will increase tire wear and fuel consumption.
- Use the air conditioner only when necessary.
- Keep the front and rear wheels in proper alignment.
- Avoid carrying unnecessary luggage or cargo.

Engine exhaust gas (carbon monoxide)



WARNING

- **Never inhale engine exhaust gas. Engine exhaust gas contains carbon monoxide, a colorless and odorless gas which is dangerous, or even lethal, if inhaled.**
- **Always properly maintain the engine exhaust system to prevent engine exhaust gas from entering the vehicle.**
- **Never run the engine in a closed space, such as a garage, except for the brief time needed to drive the vehicle in or out of it.**
- **Avoid remaining in a parked vehicle for a lengthy time while the engine is running. If that is unavoidable, then use the ventilation fan to force fresh air into the vehicle.**
- **Always keep the front ventilator inlet grille free from snow, leaves or other obstructions to ensure that the ventilation system always works properly.**
- **If at any time you suspect that**

exhaust fumes are entering the vehicle, have the problem checked and corrected as soon as possible. If you must drive under these conditions, drive only with all windows fully open.

- Keep the trunk lid closed while driving to prevent exhaust gas from entering the vehicle.

NOTE

Due to the expansion and contraction of the metals used in the manufacture of the exhaust system, you may hear a crackling sound coming from the exhaust system for a short time after the engine has been shut off. This sound is normal.

Catalytic converter

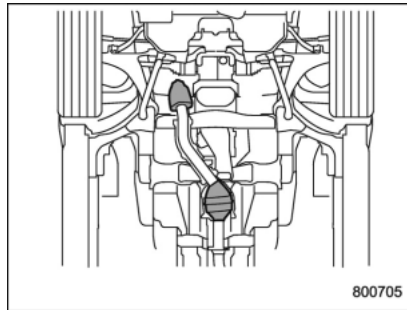

STI

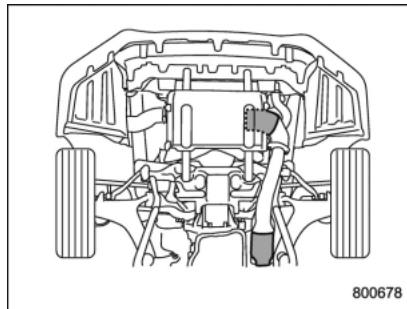

Except STI

The catalytic converter is installed in the exhaust system. It serves as a catalyst to

reduce HC, CO and NOx in exhaust gases, thus providing cleaner exhaust.

To avoid damage to the catalytic converter:

- Use only unleaded fuel. Even a small amount of leaded fuel will damage the catalytic converter.
- Never start the engine by pushing or pulling the vehicle.
- Avoid racing the engine.
- Never turn off the ignition switch while the vehicle is moving.
- Keep your engine tuned-up. If you feel the engine running rough (misfiring, back-firing or incomplete combustion), have your vehicle checked and repaired by an authorized SUBARU dealer.
- Do not apply undercoating or rust prevention treatment to the heat shield of catalytic converter and the exhaust system.
- Do not drive with an extremely low fuel level.



WARNING

- Avoid fire hazards. Do not drive or park the vehicle anywhere near flammable materials (e.g., grass, paper, rags or leaves), because the catalytic converter

operates at very high temperatures.

- **Keep everyone and flammable materials away from the exhaust pipe while the engine is running. The exhaust gas is very hot.**

Periodic inspections

To keep your vehicle in the best condition at all times, always have the recommended maintenance services listed in the maintenance schedule in the “Warranty and Maintenance Booklet” performed at the specified time or mileage intervals.

Driving in foreign countries

When planning to use your vehicle in another country:

- Confirm the availability of the correct fuel. Refer to “Fuel requirements” 7-3.
- Comply with all regulations and requirements of each country.

Driving tips for AWD models

WARNING

- Always maintain a safe driving speed according to the road and weather conditions in order to avoid having an accident on a sharp turn, during sudden braking or under other similar conditions.
- Always use the utmost care in driving – overconfidence because you are driving an All-Wheel Drive vehicle could easily lead to a serious accident.
- When you replacing or installing tire(s), all four tires must be the same for following items.
 - (a) Size
 - (b) Circumference
 - (c) Speed symbol
 - (d) Load index
 - (e) Construction
 - (f) Manufacturer
 - (g) Brand (tread pattern)
 - (h) Degrees of wear

For the items (a) to (d), you must obey the specification that is

printed on the tire placard. The tire placard is located on the bottom of driver's door pillar.

If all of four tires are not the same for items (a) to (h), there is a possibility that serious mechanical damage could occur to the drive train of your car, and affect the following.

- Ride
- Handling
- Braking
- Speedometer/Odometer calibration
- Clearance between the body and tires

It also may be dangerous and lead to loss of vehicle control, and it can lead to an accident.

CAUTION

If you use a temporary spare tire to replace a flat tire, be sure to use the original temporary spare tire stored in the vehicle. Using other sizes may result in severe mechanical damage to the drive train of your vehicle.

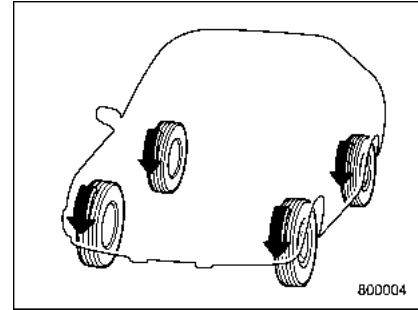

All-Wheel Drive distributes the engine power to all four wheels. AWD models provide better traction when driving on slippery, wet or snow-covered roads and when moving out of mud, dirt and sand. By shifting power between the front and rear wheels, SUBARU AWD can also provide added traction during acceleration and added engine braking force during deceleration.

Therefore, your SUBARU AWD vehicle may handle differently than an ordinary two wheel drive vehicle and it contains some features unique to AWD. For safety purposes as well as to avoid damaging the AWD system, you should keep the following tips in mind.

- An AWD model is better able to climb steeper roads under snowy or slippery

– CONTINUED –

conditions than a two wheel drive vehicle. There is little difference in handling, however, during extremely sharp turns or sudden braking. Therefore, when driving down a slope or turning corners, be sure to reduce your speed and maintain an ample distance from other vehicles.

- Always check the cold tire pressure before starting to drive. The recommended tire pressure is provided on the tire placard, which is located under the door latch on the driver's side.
- Frequent driving of an AWD vehicle under hard-driving conditions such as steep hills or dusty roads will necessitate more frequent replacement of the following items than that specified in the "Warranty and Maintenance Booklet".
 - Engine oil
 - Brake fluid
 - Rear differential gear oil
 - Manual transmission oil (MT models)
 - Continuously variable transmission fluid (CVT models)
 - Front differential gear oil (CVT models)
- There are some precautions that you must observe when towing your vehicle. For detailed information, refer to "Towing" 9-12.

Driving precaution

Water entering the engine air intake or the exhaust pipe or water splashing onto electrical parts may damage your vehicle and may cause it to stall. Never attempt to drive through rushing water; regardless of its depth, it can wash away the ground from under your tires, resulting in possible loss of traction and even vehicle rollover.

Winter driving

■ Operation during cold weather

Carry some emergency equipment, such as a window scraper, a bag of sand, flares, a small shovel and jumper cables.

Check the battery and cables. Cold temperatures reduce battery capacity. The battery must be in good condition to provide enough power for cold winter starts.

It normally takes longer to start the engine in very cold weather conditions. Use an engine oil of a proper grade and viscosity for cold weather. Using heavy summer oil will make it harder to start the engine.

Keep the door locks from freezing by squirting them with deicer or glycerin.

Forcing a frozen door open may damage or separate the rubber weather strips around the door. If the door is frozen, use hot water to melt the ice, and afterwards thoroughly wipe the water away.

Use a windshield washer fluid that contains an antifreeze solution. Do not use engine antifreeze or other substitutes because they may damage the paint of the vehicle.

SUBARU Windshield Washer Fluid contains 58.5% methyl alcohol and 41.5% surfactant, by volume. Its freezing temperature varies according to how much it is diluted, as indicated in the following table.

Washer Fluid Concentration	Freezing Temperature
30%	10.4° F (-12° C)
50%	-4° F (-20° C)
100%	-49° F (-45° C)

In order to prevent freezing of washer fluid, check the freezing temperatures in the table above when adjusting the fluid concentration to the outside temperature.

If you fill the reservoir tank with a fluid with a different concentration from the one used previously, purge the old fluid from the piping between the reservoir tank and washer nozzles by operating the washer for a certain period of time. Otherwise, if the concentration of the fluid remaining in the piping is too low for the outside temperature, it may freeze and block the nozzles.



CAUTION

- **Adjust the washer fluid concentration appropriately for the out-**

side temperature. If the concentration is inappropriate, sprayed washer fluid may freeze on the windshield and obstruct your view, and the fluid may freeze in the reservoir tank.

- **State or local regulations on volatile organic compounds may restrict the use of methanol, a common windshield washer antifreeze additive. Washer fluids containing non-methanol antifreeze agents should be used only if they provide cold weather protection without damaging your vehicle's paint, wiper blades or washer system.**

▼ Before driving your vehicle

Before entering the vehicle, remove any snow or ice from your shoes because that could make the pedals slippery and driving dangerous.

While warming up the vehicle before driving, check that the accelerator pedal, brake pedal, and all other controls operate smoothly.

Clear away ice and snow that has accumulated under the fenders to avoid making steering difficult. During severe

winter driving, stop when and where it is safe to do so and check under the fenders periodically.

▼ Parking in cold weather

Do not use the parking brake when parking for long periods in cold weather since it could freeze in that position. Instead, you should observe the following tips.

1. Place the shift lever in "1" or "R" for MT models, or the select lever in "P" for CVT models.
2. Use tire stops under the tires to prevent the vehicle from moving.

When the vehicle is parked in snow or when it snows, raise the wiper blades off the glass to prevent damage to them.

When the vehicle has been left parked after use on roads heavily covered with snow, or has been left parked during a snowstorm, icing may develop on the brake system, which could cause poor braking action. Check for snow or ice buildup on the suspension, disc brakes and brake hoses underneath the vehicle. If there is caked snow or ice, remove it, being careful not to damage the disc brakes and brake hoses and ABS harness.



WARNING

Snow can trap dangerous exhaust gases under your vehicle. Keep snow clear of the exhaust pipe and from around your vehicle if you park the vehicle in snow with the engine running.

▼ **Refueling in cold weather**

To help prevent moisture from forming in the fuel system and the risk of its freezing, use of an antifreeze additive in the fuel tank is recommended during cold weather. Use only additives that are specifically designed for this purpose. When an antifreeze additive is used, its effect lasts longer if the tank is refilled whenever the fuel level reaches half empty.

If your SUBARU is not going to be used for an extended period, it is best to have the fuel tank filled to capacity.

■ **Driving on snowy and icy roads**

To prevent skidding and slipping, avoid sudden braking, abrupt acceleration, high-speed driving, and sharp turning when driving on snowy or icy roads.

Always maintain ample distance between your vehicle and the vehicle ahead of you

to avoid the need for sudden braking.

To supplement the foot brake, use the engine brake effectively to control the vehicle speed. (Shift into a lower gear when necessary.)

Avoid shifting down abruptly. Such behavior can cause the wheels to lock, possibly leading to loss of vehicle control.

An anti-lock brake system (ABS) enhances your vehicle's braking performance on snowy and icy roads. For information on braking on slippery surfaces, refer to "ABS (Anti-lock Brake System)" 7-35 and "Vehicle Dynamics Control system" 7-38.



WARNING

Do not use the cruise control on slippery roads such as snowy or icy roads. This may cause loss of vehicle control.



CAUTION

Avoid prolonged continuous driving in snowstorms. Snow will enter the engine's intake system and may hinder the airflow, which could result in engine shutdown or even breakdown.

▼ **Wiper operation when snowing**

Before driving in cold weather, make sure the wiper blades are not frozen to the windshield or rear window.

If the wiper blades are frozen to the windshield, use the defroster and the temperature set for maximum warmth until the wiper blades are completely thawed. Refer to "Climate control" 4-1.

If your vehicle is equipped with a wiper deicer, use it. It is helpful to thaw the windshield wiper blades. Refer to "Defogger and deicer" 3-114.

When driving in snow, if frozen snow starts to stick on the surface of the windshield despite wiper operation, use the defroster and the temperature set for maximum warmth. After the windshield gets warmed enough to melt the frozen snow on it, wash it away using the windshield washer. Refer to "Windshield washer" 3-105.

Snow stuck on the wiper arm prevents the wiper from working effectively. If snow is stuck on the wiper arm, pull off the road to a safe place, then remove it. If you stop the vehicle at road side, use the hazard warning flasher to alert other drivers. Refer to "Hazard warning flasher" ¶3-8.

We recommend use of non-freezing type wiper blades (winter blades) during the seasons you could have snow and freezing temperatures. Blades of this type give superior wiping performance in snowy conditions. Be sure to use blades that are suitable for your vehicle.



CAUTION

During high-speed driving, non-freezing type wiper blades may not perform as well as standard wiper blades. If this happens, reduce the vehicle speed.

NOTE

When the season requiring non-freezing type wiper blades is over, replace them with standard wiper blades.

■ Corrosion protection

Refer to "Corrosion protection" ¶10-4.

■ Snow tires



WARNING

- When you replacing or installing winter tire(s), all four tires must be the same for following items.
 - (a) Size
 - (b) Circumference
 - (c) Speed symbol
 - (d) Load index
 - (e) Construction
 - (f) Manufacturer
 - (g) Brand (tread pattern)
 - (h) Degrees of wear

For the items (a) to (d), you must obey the specification that is printed on the tire placard. The tire placard is located on the bottom of driver's door pillar.

If all of four winter tires are not the same for items (a) to (h), there is a possibility that serious mechanical damage could occur to the drive train of your car, and affect the following.

- Ride
- Handling
- Braking

— Speedometer/Odometer calibration

— Clearance between the body and tires

It also may be dangerous and lead to loss of vehicle control, and it can lead to an accident.

- Do not use a combination of radial, belted bias or bias tires since it may cause dangerous handling characteristics and lead to an accident.

Your vehicle is equipped with "summer tires" as original equipment, which are inadequate for driving on slippery roads such as on snow-covered or icy roads.

When you choose to install winter tires on your vehicle, be sure to use the correct tire size and type. You must install four winter tires that are of the same size, construction, brand and load range and you should never mix radial, belted bias or bias tires since this may result in dangerous handling characteristics. When you choose a tire, make sure that there is enough clearance between the tire and vehicle body.

Remember to drive with care at all times regardless of the type of tires on your vehicle.

■ Tire chains



CAUTION

Tire chains cannot be used on your vehicle because of the lack of clearance between the tires and vehicle body.

NOTE

When tire chains cannot be used, use of another type of traction device (such as spring chains) may be acceptable if use on your vehicle is recommended by the device manufacturer, taking into account tire size and road conditions. Follow the device manufacturer's instructions, especially regarding maximum vehicle speed.

To help avoid damage to your vehicle, drive slowly, readjust or remove the device if it is contacting your vehicle, and do not spin your wheels. Damage caused to your vehicle by use of a traction device is not covered under warranty.

Make certain that any traction device you use is an SAE class S device, and use it on the front wheels only. Always use the utmost care when driving with a traction device. Overconfidence be-

cause you are using a traction device could easily lead to a serious accident.

■ Rocking the vehicle

If you must rock the vehicle to free it from snow, sand, or mud, depress the accelerator pedal slightly and move the shift lever/select lever back and forth between "1"/"D" and "R" repeatedly. Do not race the engine. For the best possible traction, avoid spinning the wheels when trying to free the vehicle.

When the road surface is extremely slippery, you can obtain better traction by starting the vehicle with the transmission in 2nd than in 1st (MT models and CVT models).

If your vehicle is a CVT model, for information about holding the transmission in the 2nd position, refer to "Selection of manual mode" 7-25.

Loading your vehicle



WARNING

- Never allow passengers to ride on a folded rear seatback or in the trunk. Doing so may result in serious injury.
- Stow cargo and luggage in the trunk whenever possible.
- To prevent cargo and luggage from sliding forward during braking, do not stack anything in the enlarged trunk. Keep cargo and luggage low, as close to the floor as possible.
- When you carry something inside the vehicle, secure it whenever you can to prevent it from being thrown around inside the vehicle during sudden stops, sharp turns or in an accident.
- Do not pile heavy loads on the roof. These loads raise the vehicle's center of gravity and make it more prone to tip over.
- Secure lengthy items properly to prevent them from shooting forward and causing serious injury during a sudden stop.

- Never exceed the maximum load limit. If you do, some parts on your vehicle can break, or it can change the way your vehicle handles. This could result in loss of control and cause personal injury. Also, overloading can shorten the life of your vehicle.
- Do not place cargo or luggage in or on the following locations as the item may get under the clutch, brake, or accelerator pedal and prevent the pedals from being depressed properly, block the driver's vision, or hit the driver or passengers, causing an accident:
 - At the feet of the driver
 - On the front passenger or rear seats (when stacking items)
 - On the rear shelf
 - On the instrument panel
 - On the dashboard

CAUTION

Do not carry spray cans, containers with flammable or corrosive liquids or any other dangerous items inside the vehicle.

NOTE

For better fuel economy, do not carry unneeded cargo.

Vehicle capacity weight

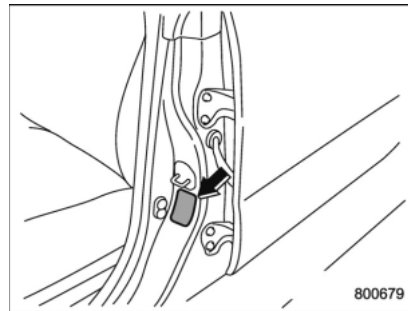

Vehicle placard

The load capacity of your vehicle is determined by weight, not by available cargo space. The maximum load you can carry in your vehicle is shown on the vehicle placard attached to the driver's side door pillar. It includes the total weight of the driver and all passengers and their belongings, any optional equipment such as a roof rack or bike carrier, etc.

■ GVWR and GAWR (Gross Vehicle Weight Rating and Gross Axle Weight Rating)

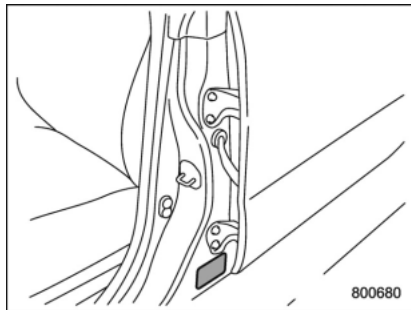

Certification label

The certification label attached to the driver's side doorjamb shows GVWR (Gross Vehicle Weight Rating) and GAWR (Gross Axle Weight Rating).

The GVW (Gross Vehicle Weight) must never exceed the GVWR. GVW is the combined total of weight of the vehicle, fuel, driver, all passengers, luggage, and any optional equipment. Therefore, the GVW changes depending on the situation. The GVWR equals Curb Weight (actual weight of your vehicle – including standard equipment, fluids, emergency tools and spare tire assembly) plus the vehicle

capacity weight.

In addition, the total weight applied to each axle (GAW) must never exceed the GAWR. The front and rear GAWs can be adjusted by relocating luggage inside the vehicle.

Even if the total weight of your luggage is lower than the vehicle capacity weight, either front or rear GAW may exceed the GAWR, depending on the distribution of the luggage.

When possible, the load should be evenly distributed throughout the vehicle.

If you carry heavy loads in the vehicle, you should confirm that GVW and front and rear GAWs are within the GVWR and GAWR by putting your vehicle on a vehicle scale, found at a commercial weighing station.

Do not use replacement tires with a lower load range than the originals because they may lower the GVWR and GAWR limitations. Replacement tires with a higher load range than the originals do not increase the GVWR and GAWR limitations.

Trailer towing

Your vehicle is neither designed nor intended to be used for trailer towing. Therefore, never tow a trailer with your vehicle.

SUBARU assumes no responsibility for injuries or vehicle damage that may result from trailer towing, from any trailer towing equipment or from any errors or omissions in the instructions accompanying such equipment. SUBARU warranties do not apply to vehicle damage or malfunction caused by trailer towing.

If you park your vehicle in case of an emergency	9-2	If no steam is coming from the engine compartment	9-11
Temporary spare tire.....	9-2	Towing	9-12
Maintenance tools	9-3	Towing and tie-down hooks.....	9-12
Flat tires	9-4	Using a flat-bed truck.....	9-14
Changing a flat tire.....	9-4	Towing with all wheels on the ground.....	9-15
Tire pressure monitoring system (TPMS) (U.S.-spec. models)	9-8	Access key – if access key does not operate properly	9-16
Jump starting	9-9	Locking and unlocking.....	9-16
How to jump start.....	9-9	Switching power	9-16
Engine overheating	9-11	Starting engine	9-17
If steam is coming from the engine compartment.....	9-11	Moonroof (if equipped) – if the moonroof does not close	9-17
		If your vehicle is involved in an accident	9-18

If you park your vehicle in case of an emergency

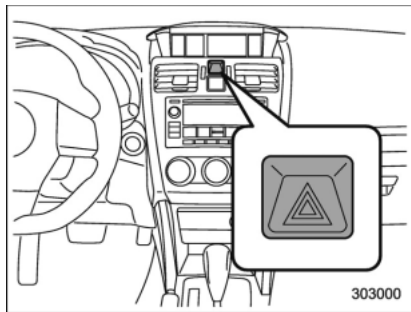

The hazard warning flasher should be used in day or night to warn other drivers when you have to park your vehicle under emergency conditions.

Avoid stopping on the road. It is best to safely pull off the road if a problem occurs.

The hazard warning flasher can be activated regardless of the ignition switch position.

Turn on the hazard warning by pushing the hazard warning flasher switch. Turn it off by pushing the switch again.

NOTE

When the hazard warning flasher is on, the turn signals do not work.

Temporary spare tire

WARNING

When a spare tire is mounted or a wheel rim is replaced without the original pressure sensor/transmitter being transferred, the low tire pressure warning light will illuminate steadily after blinking for approximately one minute. This indicates the tire pressure monitoring system (TPMS) is unable to monitor all four road wheels. Contact your SUBARU dealer as soon as possible for tire and sensor replacement and/or system resetting.

CAUTION

- Never use any temporary spare tire other than the original. Using other sizes may result in severe mechanical damage to the drive train of your vehicle.
- Always conform to the following instructions when using the temporary spare tire. Otherwise, a seriously dangerous situation may occur.

The temporary spare tire is smaller and lighter than a conventional tire and is designed for emergency use only. Remove the temporary spare tire and re-install the conventional tire as soon as possible because the spare tire is designed only for temporary use.

Check the inflation pressure of the temporary spare tire periodically to keep the tire ready for use. The correct pressure is as follows.

Mexico models: 33 psi (230 kPa, 2.3 kgf/cm²)

Other models: 60 psi (420 kPa, 4.2 kgf/cm²)

When using the temporary spare tire, note the following.

- Do not exceed 50 mph (80 km/h).
- Do not put a tire chain on the temporary spare tire. Because of the smaller tire size, a tire chain will not fit properly.
- Do not use two or more temporary spare tires at the same time.
- Do not drive over obstacles. This tire has a smaller diameter, so road clearance is reduced.

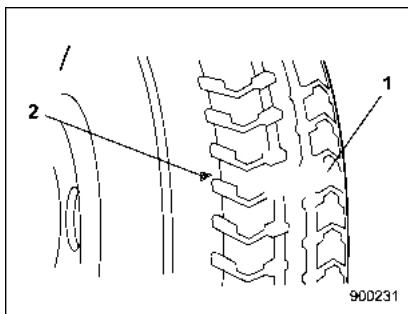

- 1) Tread wear indicator bar
- 2) Indicator location mark

- When the wear indicator appears on the tread, replace the tire.
- The temporary spare tire must be used only on a rear wheel. If a front wheel tire gets punctured, replace the wheel with a rear wheel and install the temporary spare tire in place of the removed rear wheel.
- Always set the driver's control center differential to the manual mode and adjust the initial LSD torque to the minimum.

Maintenance tools

Your vehicle is equipped with the following maintenance tools.

- Jack
- Jack handle
- Screwdriver
- Towing hook (eye bolt)
- Wheel nut wrench

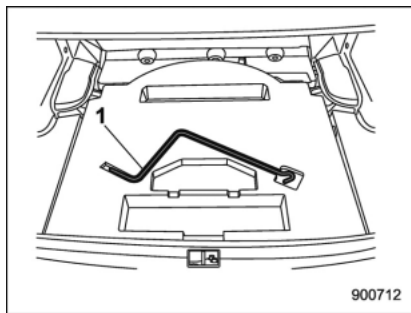

1) Jack handle

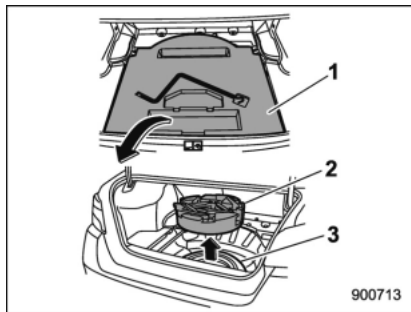

- 1) Under-floor storage compartment (if equipped) (Refer to "Under-floor storage compartment" 9-6-11.)
- 2) Tool bucket
- 3) Spare tire

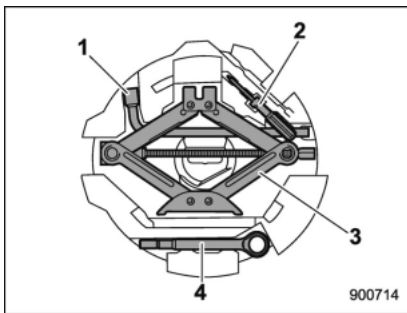

- 1) Wheel nut wrench
- 2) Screwdriver
- 3) Jack
- 4) Towing hook (eye bolt)

A jack handle is stored under the floor of the trunk. A jack and a towing hook are stored in the recess of the spare tire wheel. A screwdriver and a wheel nut wrench are stored in the vinyl bag. These tools can also be stored in the tool bucket.

NOTE

For how to use the jack, refer to "Flat tires" 9-4.

Flat tires

If you have a flat tire while driving, never brake suddenly; keep driving straight ahead while gradually reducing speed. Then slowly pull off the road to a safe place.

Changing a flat tire

WARNING

- Do not jack up the vehicle on an incline or a loose road surface. The jack can come out of the jacking point or sink into the ground and this can result in a severe accident.
- Use only the jack provided with your vehicle. The jack supplied with the vehicle is designed only for changing a tire. Never get under the vehicle while supporting the vehicle with this jack.

- **Always turn off the engine before raising the flat tire off the ground using the jack. Never swing or push the vehicle supported with the jack. The jack can come out of the jacking point due to a jolt and this can result in a severe accident.**

1. Park on a hard, level surface, whenever possible, then stop the engine.
2. Set the parking brake securely and shift the shift lever in reverse (MT models) or the select lever to the "P" (Park) position (CVT models).
3. Turn on the hazard warning flasher and have everyone get out of the vehicle.

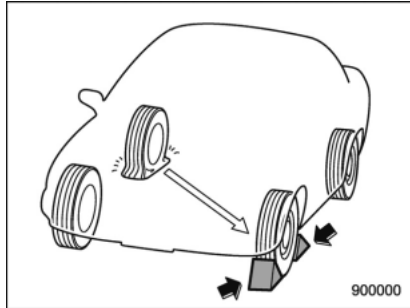

4. Put wheel blocks at the front and rear of the tire diagonally opposite the flat tire.

5. Take out the jack, jack handle and wheel nut wrench.

The tools and the spare tire are stored under the floor of the trunk. Refer to "Maintenance tools" 9-3.

NOTE

Make sure that the jack is well lubricated before using it.

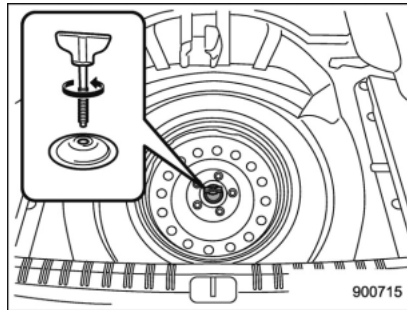

6. Take out the tool bucket and turn the attaching bolt counterclockwise, then take the spare tire out.

NOTE

If the spare tire provided in your vehicle is a temporary spare tire, carefully read "Temporary spare tire" 9-2 and strictly follow the instructions.

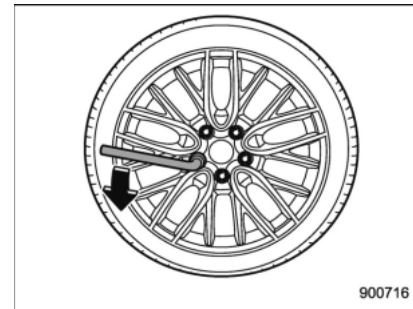

7. Loosen the wheel nuts using the wheel nut wrench but do not remove the nuts.

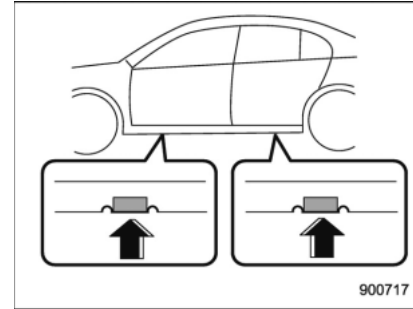

Jack-up points

8. Place the jack under the side sill at the front or rear jack-up point closest to the flat tire.

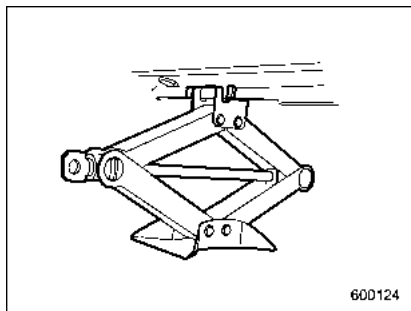

Turn the jackscrew by hand until the jack head engages firmly into the jack-up point.

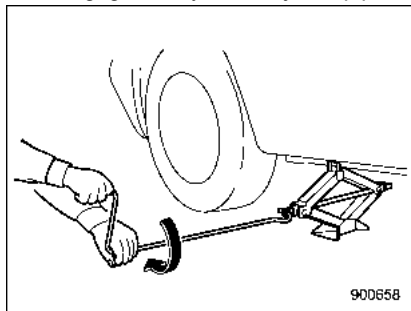

9. Insert the jack handle into the jackscrew, and turn the handle until the tire clears the ground. Do not raise the vehicle higher than necessary.

10. Remove the wheel nuts and the flat tire.

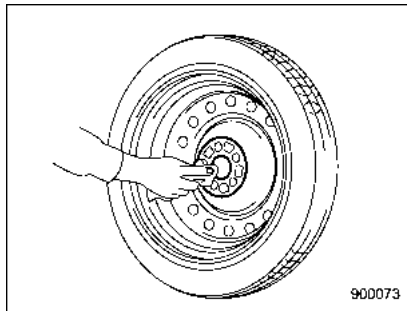
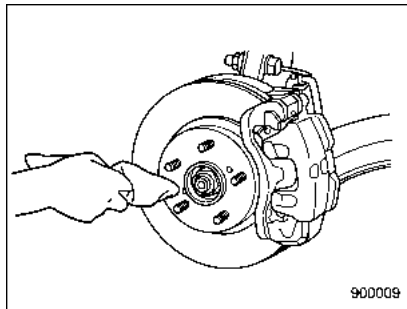

11. Before putting the spare tire on, perform the following steps.

- Clean the mounting surface of the wheel and hub with a cloth.

- Clean the threaded parts with a cloth and check the conditions there.

CAUTION

If the threaded part was damaged, you should immediately contact your SUBARU dealer.

12. Put on the spare tire. Replace the wheel nuts. Tighten them by hand.

WARNING

Do not use oil or grease on the wheel studs or nuts when the spare tire is installed. This could cause the nuts to become loose and lead to an accident.

13. Turn the jack handle counterclockwise to lower the vehicle.

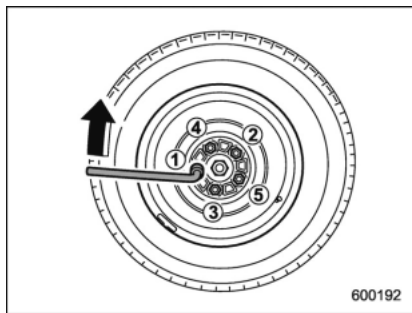

14. Use the wheel nut wrench to securely tighten the wheel nuts to the specified torque, following the tightening order in the illustration.

For the wheel nut tightening torque, refer to "Tires" 12-8. Never use your foot on the wheel nut wrench or a pipe extension on the wrench because you may exceed the specified torque. Have the wheel nut torque checked at the nearest automotive service facility.

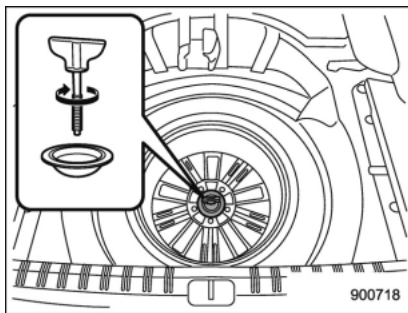

Except STI

15. Store the flat tire in the spare tire compartment. For except STI models, put in the spacer and tighten the attaching bolt firmly.

Also store the jack, jack handle and wheel nut wrench in their storage locations.

WARNING

- **Never place a tire or tire changing tools in the passenger compartment after changing wheels. In a sudden stop or collision, loose equipment could strike occupants and cause injury. Store the tire and all tools in the proper place.**

- **When you store a flat tire, be sure to set the rear seatback to the upright position. If you fold down the seatback, an accident or injury may occur when the flat tire suddenly moves.**

■ **Tire pressure monitoring system (TPMS) (U.S.-spec. models)**

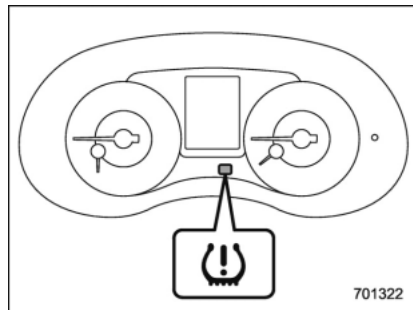

The tire pressure monitoring system provides the driver with the warning message indicated by sending a signal from a sensor that is installed in each wheel when tire pressure is severely low.

The tire pressure monitoring system will activate only when the vehicle is driven. Also, this system may not react immediately to a sudden drop in tire pressure (for example, a blow-out caused by running over a sharp object).



WARNING

If the low tire pressure warning light illuminates while driving, never

brake suddenly and keep driving straight ahead while gradually reducing speed. Then slowly pull off the road to a safe place. Otherwise an accident involving serious vehicle damage and serious personal injury could occur.

Check the pressure for all four tires and adjust the pressure to the COLD tire pressure shown on the vehicle placard on the door pillar on the driver's side. If this light still illuminates while driving after adjusting the tire pressure, a tire may have significant damage and a fast leak that causes the tire to lose air rapidly. If you have a flat tire, replace it with a spare tire as soon as possible.

When a spare tire is mounted or a wheel rim is replaced without the original pressure sensor/transmitter being transferred, the low tire pressure warning light will illuminate steadily after blinking for approximately one minute. This indicates the TPMS is unable to monitor all four road wheels. Contact your SUBARU dealer as soon as possible for tire and sensor replacement and/or system resetting.

Do not inject any tire liquid or

aerosol tire sealant into the tires, as this may cause a malfunction of the tire pressure sensors.

If the light illuminates steadily after blinking for approximately one minute, promptly contact a SUBARU dealer to have the system inspected.

Jump starting

WARNING

- **Battery fluid is SULFURIC ACID. Do not let it come in contact with the eyes, skin, clothing or the vehicle.**
If battery fluid gets on you, thoroughly flush the exposed area with water immediately. Get medical help if the fluid has entered your eyes.
If battery fluid is accidentally swallowed, immediately drink a large amount of milk or water, and obtain immediate medical help.
Keep everyone including children away from the battery.
- **The gas generated by a battery explodes if a flame or spark is brought near it. Do not smoke or light a match while jump starting.**
- **Never attempt jump starting if the discharged battery is frozen. It could cause the battery to burst or explode.**
- **Whenever working on or around a battery, always wear suitable**

eye protectors, and remove metal objects such as rings, bands or other metal jewelry.

- **Be sure the jumper cables and clamps on them do not have loose or missing insulation.**
Do not jump start unless cables in suitable condition are available.
- **A running engine can be dangerous. Keep your fingers, hands, clothing, hair and tools away from the cooling fan, belts and any other moving engine parts. Removing rings, watches and ties is advisable.**
- **Jump starting is dangerous if it done incorrectly. If you are unsure about the proper procedure for jump starting, consult a competent mechanic.**

When your vehicle does not start due to a run down (discharged) battery, the vehicle may be jump started by connecting your battery to another battery (called the booster battery) with jumper cables.

■ How to jump start

1. Make sure the booster battery is 12 volts and the negative terminal is grounded.
2. If the booster battery is in another vehicle, do not let the two vehicles touch.
3. Turn off all unnecessary lights and accessories.
4. Connect the jumper cables exactly in the sequence illustrated.

9-10 In case of emergency/Jump starting

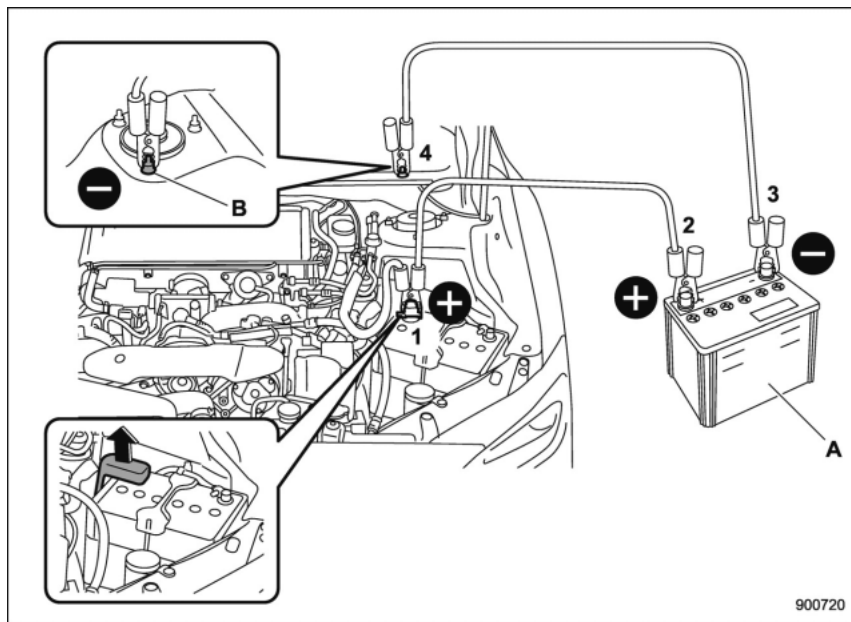

- A) Booster battery
B) Strut mounting nut

- (1) Connect one jumper cable to the positive (+) terminal on the discharged battery.
- (2) Connect the other end of the jumper cable to the positive (+) terminal of the booster battery.
- (3) Connect one end of the other cable to the negative (-) terminal of the booster battery.
- (4) Connect the other end of the cable to the strut mounting nut of the vehicle with the discharged battery.

Make sure that the cables are not near any moving parts and that the cable clamps are not in contact with any other metal.

5. Start the engine of the vehicle with the booster battery and run it at moderate speed. Then start the engine of the vehicle that has the discharged battery.
6. When finished, carefully disconnect the cables in exactly the reverse order.

Engine overheating



WARNING

Never attempt to remove the radiator cap until the engine has been shut off and has fully cooled down. When the engine is hot, the coolant is under pressure. Removing the cap while the engine is still hot could release a spray of boiling hot coolant, which could burn you very seriously.

If the engine overheats, safely pull off the road and stop the vehicle in a safe location.

■ If steam is coming from the engine compartment

- Turn off the engine and get everyone away from the vehicle until it cools down.
- Contact an authorized SUBARU dealer.

■ If no steam is coming from the engine compartment

1. Keep the engine running at idling speed.
2. Open the engine hood to ventilate the

engine compartment. Refer to “Engine hood” 11-8.

Confirm that the cooling fan is turning. If the fan is not turning, immediately turn off the engine and contact an authorized SUBARU dealer for repair.

3. After the engine coolant temperature has dropped, turn off the engine.

If temperature gauge stays in the overheated zone, turn off the engine. Refer to “Temperature gauge” 3-11.

4. After the engine has fully cooled down, check the coolant level in the reserve tank. If the coolant level is below the “LOW” mark, add coolant up to the “FULL” mark.

NOTE

For details about how to check the coolant level or how to add coolant, refer to “Engine coolant” 11-17.

5. If there is no coolant in the reserve tank, add coolant to the reserve tank. Then remove the radiator cap and fill the radiator with coolant.

If you remove the radiator cap from a hot radiator, first wrap a thick cloth around the radiator cap, then turn the cap counterclockwise slowly without pressing down until it stops. Release the pressure from the radiator. After the pressure has been

fully released, remove the cap by pressing down and turning it.

Towing

If towing is necessary, it is best done by your SUBARU dealer or a commercial towing service. Observe the following procedures for safety.

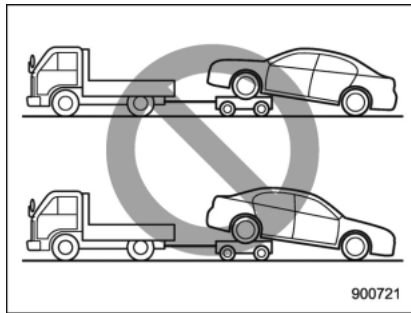

WARNING

Never tow AWD models (both CVT and MT models) with the front wheels raised off the ground while the rear wheels are on the ground, or with the rear wheels raised off the ground while the front wheels are on the ground. This will cause the vehicle to spin away due to the operation or deterioration of the center differential.

■ Towing and tie-down hooks

The towing hooks should be used only in an emergency (e.g., to free a stuck vehicle from mud, sand or snow).



CAUTION

- Use only the specified towing hook and tie-down hook. Never use suspension parts or other parts of the body for towing or tie-down purposes.
- To prevent deformation to the front bumper and the towing hook, do not apply excessive lateral load to the towing hook.

Front towing hook:

1. Take the towing hook, screwdriver and wheel nut wrench out of the tool bucket.

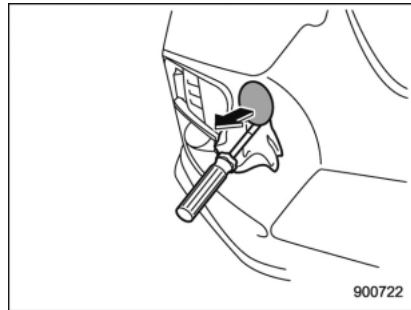

2. Cover the tip of a flat-head screwdriver with vinyl tape or cloth so that it will not scratch the bumper. Insert the flat-head screwdriver into the cutout of the cover and pry open the cover.

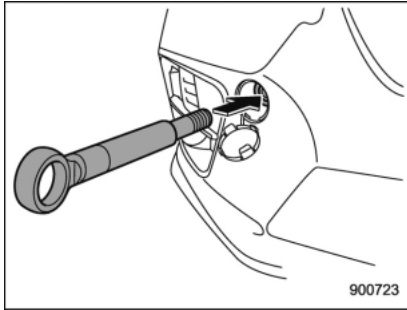

3. Screw the towing hook into the thread hole until its thread can no longer be seen.

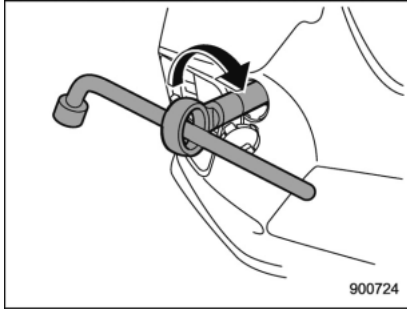

4. Tighten the towing hook securely using the wheel nut wrench.

After towing, remove the towing hook from

the vehicle and stow it in the tool bucket. Fit the towing hook cover on the bumper.

WARNING

- Do not use the towing hook except when towing your vehicle.
- Be sure to remove the towing hook after towing. Leaving the towing hook mounted on the vehicle could interfere with proper operation of the SRS airbag system in a frontal collision.

Rear towing hook:

1. Take the towing hook, screwdriver and wheel nut wrench out of the tool bucket.

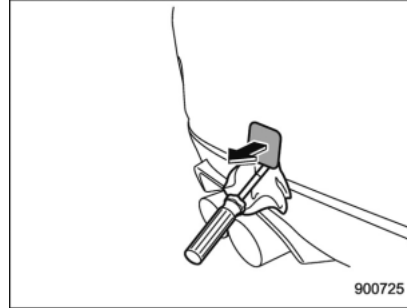

2. Pry off the cover on the rear bumper using a screwdriver, and you will find a

threaded hole for attaching the towing hook.

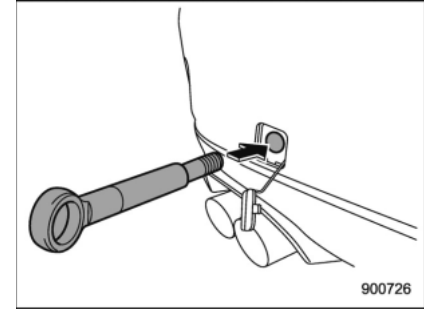

3. Screw the towing hook into the thread hole until its thread can no longer be seen.

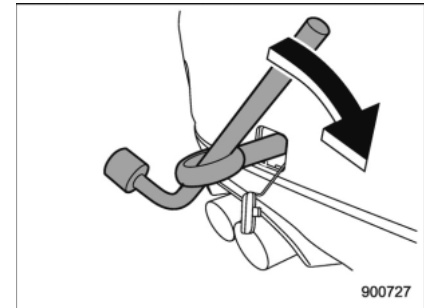

4. Tighten the towing hook securely using the wheel nut wrench.

9-14 In case of emergency/Towing

After towing, remove the towing hook from the vehicle and stow it in the tool bucket. Fit the towing hook cover on the bumper.

WARNING

Do not use the towing hook except when towing your vehicle.

Front tie-down hooks:

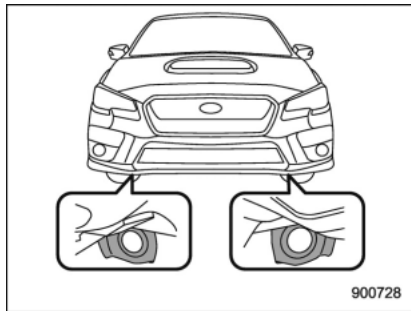

The front tie-down hooks are located between each of the front tires and the front bumper.

Rear tie-down holes:

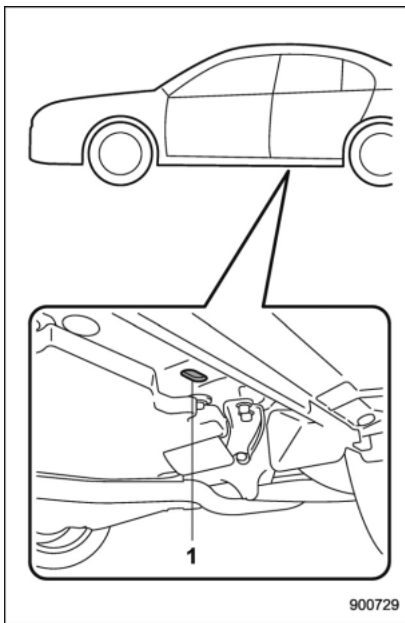

1) Rear tie-down hole

The rear tie-down holes are located near each of the jack-up reinforcements.

There is a plug in each rear tie-down hole. To use the rear tie-down holes, remove

the plugs. After using the rear tie-down holes, return the plugs to their original places.

WARNING

Use the rear tie-down holes only for downward anchoring. If they are used to anchor the vehicle in any other direction, cables may slip out of the holes, possibly causing a dangerous situation.

■ Using a flat-bed truck

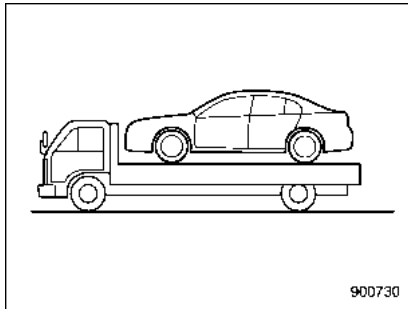

This is the best way to transport your vehicle. Use the following procedures to ensure safe transportation.

1. Shift the select lever into the "P" position for CVT models. Shift the shift

- lever into the "1st" position for MT models.
2. Apply the parking brake firmly.
 3. Secure the vehicle onto the carrier properly with safety chains. Each safety chain should be equally tightened and care must be taken not to pull the chains so tightly that the suspension bottoms out.

**CAUTION**

If your vehicle has a front under-spoiler and rear underspoiler (both optional), be careful not to scrape them when placing the vehicle on the carrier and when removing the vehicle from the carrier.

■ Towing with all wheels on the ground

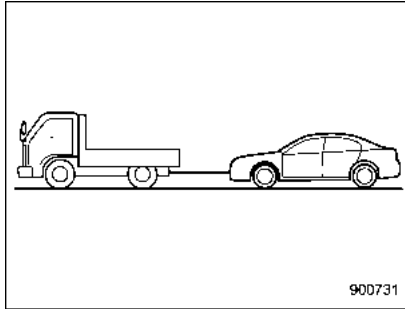

1. Release the parking brake and put the transmission in the "N"/neutral position.
2. The ignition switch should be in the "ON" position while the vehicle is being towed.
3. Take up slack in the towline slowly to prevent damage to the vehicle.

**WARNING**

- Never turn the ignition switch to the "LOCK"/"OFF" position while the vehicle is being towed because the steering wheel and the direction of the wheels will be locked.

- Remember that the brake booster and power steering do not function when the engine is not running. Because the engine is turned off, it will take greater effort to operate the brake pedal and steering wheel.

**CAUTION**

- If transmission failure occurs, transport your vehicle on a flat-bed truck.
- For CVT models, the traveling speed must be limited to less than 20 mph (30 km/h) and the traveling distance to less than 31 miles (50 km). For greater speeds and distances, transport your vehicle on a flat-bed truck.

Access key – if access key does not operate properly

CAUTION

Keep metallic objects, magnetic sources and signal transmitters away from the area between the access key and the push-button ignition switch. They may interfere with the communication between the access key and the push-button ignition switch.

If the locking/unlocking procedures, power switch procedures or engine start procedures cannot be operated because of strong radio signals in the surrounding area or a low battery condition of the access key, perform the following procedure. When the battery of the access key is discharged, replace it with a new one. Refer to "Replacing access key battery" 11-49.

Locking and unlocking

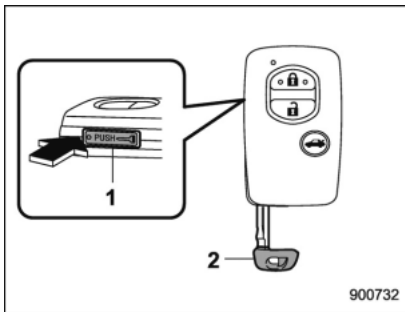

- 1) Release button
- 2) Mechanical key

While pressing the release button of the access key, take out the mechanical key. Lock or unlock the driver's door with the mechanical key.

NOTE

After locking or unlocking, be sure to reinsert the mechanical key into the access key.

Switching power

1. Apply the parking brake.
2. Shift the shift lever into neutral (MT models) or the select lever into the "P" position (CVT models).

3. Depress the clutch pedal (MT models) or brake pedal (CVT models).

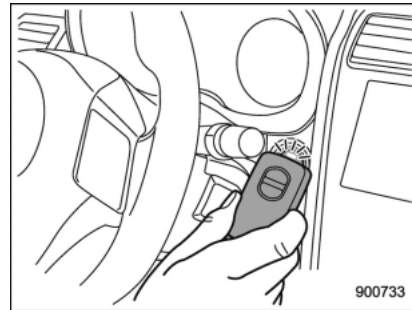

4. Hold the access key with the buttons facing you, and touch the push-button ignition switch with it.

When the communication between the access key and the vehicle is completed, a chime (ding) will sound. At the same time, the status of the push-button ignition switch changes to either of the following.

- When the keyless access with push-button start system is deactivated: "ACC"
 - Under other conditions: "ON"
5. When the keyless access with push-button start system is deactivated, press the push-button ignition switch with the clutch pedal (MT models) or brake pedal (CVT models) released. The status of the

push-button ignition switch then changes to “ON”.

NOTE

If the power does not switch even though the above procedure was followed precisely, contact your SUBARU dealer.

■ Starting engine

1. Apply the parking brake.
2. Shift the shift lever into neutral (MT models) or the select lever into the “P” position (CVT models).
3. Depress the brake pedal.
4. Depress the clutch pedal (MT models).

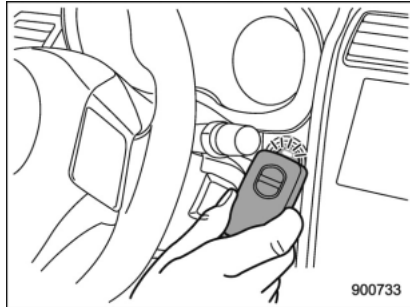

5. Hold the access key with the buttons facing you, and touch the push-button

ignition switch with it.

When the communication between the access key and the vehicle is completed, a chime (ding) will sound. At the same time, the push-button ignition switch turns to the “ACC” or “ON” position.

6. Within 5 seconds after the push-button ignition switch turns to the “ACC” or “ON” position, while depressing the brake pedal (all models) and the clutch pedal (MT models), press the push-button ignition switch.

NOTE

If the engine does not start even though the above procedure was followed precisely, contact your SUBARU dealer.

Moonroof (if equipped) – if the moonroof does not close

If the moonroof does not close, we recommend that you have the system checked by a SUBARU dealer.

If your vehicle is involved in an accident



CAUTION

If your vehicle is involved in an accident, be sure to inspect the ground under the vehicle before restarting the engine. If you find that fuel has leaked on the ground, do not try to restart the engine. The fuel system has been damaged and is in need of repair. Immediately contact the nearest automotive service facility. We recommend that you consult your SUBARU dealer.

Your vehicle has a fuel pump shut off system. When the vehicle sustains an impact in an accident, etc., the fuel pump shut off system stops supplying the fuel in order to minimize fuel leakage.

Perform the following procedures to restart the engine after the system is activated.

Models without “keyless access with push-button start system”:

1. Turn the ignition switch to the “LOCK” or “ACC” position.
2. Restart the engine.

Models with “keyless access with push-button start system”:

1. Turn the push-button ignition switch to the “ACC” or “OFF” position.
2. Restart the engine.

Exterior care	10-2	Cleaning the interior	10-5
Washing	10-2	Seat fabric	10-5
Waxing and polishing	10-3	Leather seat materials	10-5
Cleaning aluminum wheels	10-3	Synthetic leather upholstery	10-5
Corrosion protection	10-4	Climate control panel, audio panel, instrument panel, console panel, and switches	10-5
Most common causes of corrosion	10-4	Monitor	10-6
To help prevent corrosion	10-4		

Exterior care

■ Washing

CAUTION

- When washing the vehicle, the brakes may get wet. As a result, the brake stopping distance will be longer. To dry the brakes, drive the vehicle at a safe speed while lightly depressing the brake pedal to heat up the brakes.
- Do not wash the engine compartment and area adjacent to it. If water enters the engine air intake or electrical parts, it will cause engine trouble or a malfunction of electrical equipment.
- Do not use any organic solvents when washing the surface of the bulb assembly cover. However, if a detergent with organic solvents is used to wash the cover surface, completely rinse off the detergent with water. Otherwise, the cover surface may be damaged.

NOTE

When having your vehicle washed in an automatic car wash, make sure beforehand that the car wash is of suitable type.

The best way to preserve your vehicle's beauty is frequent washing. Wash the vehicle at least once a month to avoid contamination by road grime.

Wash dirt off with a wet sponge and plenty of lukewarm or cold water. Do not wash the vehicle with hot water and in direct sunlight.

Salt, chemicals, insects, tar, soot, tree sap, and bird droppings should be washed off by using a light detergent, as required. If you use a light detergent, make certain that it is a neutral detergent. Do not use strong soap or chemical detergents. All cleaning agents should be promptly flushed from the surface and not allowed to dry there. Rinse the vehicle thoroughly with plenty of lukewarm water. Wipe the remaining water off with a chamois or soft cloth.

▼ Washing the underbody

Chemicals, salts and gravel used for deicing road surfaces are extremely corrosive, accelerating the corrosion of underbody components, such as the exhaust

system, fuel and brake lines, brake cables, floor pan and fenders, and suspension.

Thoroughly flush the underbody and inside of the fenders with lukewarm or cold water at frequent intervals to reduce the harmful effects of such agents.

Mud and sand adhering to the underbody components may accelerate their corrosion.

After driving off-road or on muddy or sandy roads, wash the mud and sand off the underbody. Carefully flush the suspension and axle parts, as they are particularly prone to mud and sand buildup. Do not use a sharp-edged tool to remove caked mud.

CAUTION

- Be careful not to damage brake hoses, sensor harnesses, and other parts when washing suspension components.
- Be careful not to flush the engine bottom for a long time. It may cause damage of some electrical parts.

▼ Using a warm water washer

- Keep a good distance of 12 in (30 cm) or more between the washer nozzle and the vehicle.
- Do not wash the same area continuously.
- If a stain will not come out easily, wash by hand. Some warm water washers are of the high temperature, high pressure type, and they can damage or deform the resin parts such as moldings, or cause water to leak into the vehicle.

■ Waxing and polishing

Always wash and dry the vehicle before waxing and polishing.

Use a good quality polish and wax and apply them according to the manufacturer's instructions. Wax or polish when the painted surface is cool.

Be sure to polish and wax the chrome trim, as well as the painted surfaces. Loss of wax on a painted surface leads to loss of the original luster and also quickens the deterioration of the surface. It is recommended that a coat of wax be applied at least once a month, or whenever the surface no longer repels water.

If the appearance of the paint has diminished to the point where the luster or tone cannot be restored, lightly polish the

surface with a fine-grained compound. Never polish just the affected area, but include the surrounding area as well. Always polish in only one direction. A No. 2000 grain compound is recommended. Never use a coarse-grained compound. Coarse-grained compounds have a smaller grain-size number and could damage the paint. After polishing with a compound, coat with wax to restore the original luster. Frequent polishing with a compound or an incorrect polishing technique will result in removing the paint layer and exposing the undercoat. When in doubt, it is always best to contact your SUBARU dealer or an auto paint specialist.



CAUTION

Do not use any agents with organic solvents on the surface of the bulb assembly cover. However, if a polish or wax with organic solvents is applied to the cover surface, completely wipe off the polish or wax. Otherwise, the cover surface may be damaged.

NOTE

Be careful not to block the windshield washer nozzles with wax when waxing

the vehicle.

■ Cleaning aluminum wheels

- Promptly wipe the aluminum wheels clean of any kind of grime or agent. If dirt is left on too long, it may be difficult to clean off.
- Do not use soap containing grit to clean the wheels. Be sure to use a neutral cleaning agent, and later rinse thoroughly with water. Do not clean the wheels with a stiff brush or expose them to a high-speed washing device.
- Clean the vehicle (including the aluminum wheels) with water as soon as possible when it has been splashed with sea water, exposed to sea breezes, or driven on roads treated with salt or other agents.

Corrosion protection

Your SUBARU has been designed and built to resist corrosion. Special materials and protective finishes have been used on most parts of the vehicle to help maintain fine appearance, strength, and reliable operation.

■ Most common causes of corrosion

The most common causes of corrosion are:

1. The accumulation of moisture retaining dirt and debris in body panel sections, cavities, and other areas.
2. Damage to paint and other protective coatings caused by gravel and stone chips or minor accidents.

Corrosion is accelerated on the vehicle when:

1. It is exposed to road salt or dust control chemicals, or used in coastal areas where there is more salt in the air, or in areas where there is considerable industrial pollution.
2. It is driven in areas of high humidity, especially when temperatures range just above freezing.
3. Dampness in certain parts of the

vehicle remains for a long time, even though other parts of the vehicle may be dry.

4. High temperatures will cause corrosion to parts of the vehicle which cannot dry quickly due to lack of proper ventilation.

■ To help prevent corrosion

Wash the vehicle regularly to prevent corrosion of the body and suspension components. Also, wash the vehicle promptly after driving on any of the following surfaces.

- roads that have been salted to prevent them from freezing in winter
- mud, sand, or gravel
- coastal roads

After the winter has ended, it is recommended that the underbody be given a very thorough washing.

Before the beginning of winter, check the condition of underbody components, such as the exhaust system, fuel and brake lines, brake cables, suspension, steering system, floor pan, and fenders. If any of them are found to be rusted, they should be given an appropriate rust prevention treatment or should be replaced. Contact your SUBARU dealer to perform this kind

of maintenance and treatment if you need assistance.

Repair chips and scratches in the paint as soon as you find them.

Check the interior of the vehicle for water and dirt accumulation under the floor mats because that could cause corrosion. Occasionally check under the mats to make sure the area is dry.

Keep your garage dry. Do not park your vehicle in a damp, poorly ventilated garage. In such a garage, corrosion can be caused by dampness. If you wash the vehicle in the garage or put the vehicle into the garage when wet or covered with snow, that can cause dampness.

If your vehicle is operated in cold weather and/or in areas where road salts and other corrosive materials are used, the door hinges and locks, and hood latch should be inspected and lubricated periodically.

Cleaning the interior

Use a soft, damp cloth to clean the climate control panel, audio equipment, instrument panel, center console, combination meter panel, and switches. (Do not use organic solvents.)

■ Seat fabric

Remove loose dirt, dust or debris with a vacuum cleaner. If the dirt is caked on the fabric or hard to remove with a vacuum cleaner, use a soft brush then vacuum it. Wipe the fabric surface with a tightly wrung cloth and dry the seat fabric thoroughly. If the fabric is still dirty, wipe using a solution of mild soap and lukewarm water then dry thoroughly.

If the stain does not come out, try a commercially-available fabric cleaner. Use the cleaner on a hidden place and make sure it does not affect the fabric adversely. Use the cleaner according to its instructions.



CAUTION

When cleaning the seat, do not use benzine, paint thinner, or any similar materials.

■ Leather seat materials

The leather used by SUBARU is a high quality natural product which will retain its distinctive appearance and feel for many years with proper care.

Allowing dust or road dirt to build up on the surface can cause the material to become brittle and to wear prematurely. Regular cleaning with a soft, moist, natural fiber cloth should be performed monthly, taking care not to soak the leather or allow water to penetrate the stitched seams.

A mild detergent suitable for cleaning woolen fabrics may be used to remove difficult dirt spots, rubbing with a soft, dry cloth afterwards to restore the luster. If your SUBARU is to be parked for a long time in bright sunlight, it is recommended that the seats and head restraints be covered, or the windows shaded, to prevent fading or shrinkage.

Minor surface blemishes or bald patches may be treated with a commercial leather spray lacquer. You will discover that each leather seat section will develop soft folds or wrinkles, which is characteristic of genuine leather.

■ Synthetic leather upholstery

The synthetic leather material used on the SUBARU may be cleaned using mild soap or detergent and water, after first vacuuming or brushing away loose dirt. Allow the soap to soak in for a few minutes and wipe off with a clean, damp cloth. Commercial foam-type cleaners suitable for synthetic leather materials may be used when necessary.



CAUTION

Strong cleaning agents such as solvents, paint thinners, window cleaner or fuel must never be used on leather or synthetic interior materials. Doing so could damage the surface and cause the color to deteriorate.

■ Climate control panel, audio panel, instrument panel, console panel, and switches

Use a soft, damp cloth to clean the climate control panel, audio equipment, instrument panel, center console, combination meter panel, and switches.



CAUTION

- Do not use organic solvents such as paint thinners or fuel, or strong cleaning agents that contain those solvents.
- Do not use chemical solvents that contain silicone on the vehicle audio system, electrical components of the air-conditioner or any switches. If silicone adheres to these parts, it may cause damage to electrical components.

■ **Monitor**

To clean the navigation/multi function display monitor, wipe it with a silicone cloth or with a soft cloth. If the monitor is extremely dirty, clean it with a soft cloth moistened with neutral detergent then carefully wipe off any remaining detergent.



CAUTION

- Do not spray neutral detergent directly onto the monitor. Doing so could damage the monitor's components.
- Do not wipe the monitor with a hard cloth. Doing so could scratch the monitor.
- Do not use cleaning fluid that contains thinner, fuel, or any other volatile substance. Such cleaning fluid could erase the lettering on the switches at the bottom of the monitor.

Maintenance and service

Maintenance schedule	11-3	Continuously variable transmission fluid	11-22
Maintenance precautions.....	11-3	Front differential gear oil (CVT models).....	11-22
Before checking or servicing in the engine compartment.....	11-4	Recommended grade and viscosity	11-22
When checking or servicing in the engine compartment.....	11-4	Rear differential gear oil.....	11-23
When checking or servicing in the engine compartment while the engine is running.....	11-5	Recommended grade and viscosity	11-23
Maintenance tips	11-5	Power steering fluid (STI)	11-23
Removing and reinstalling clips.....	11-5	Checking the fluid level.....	11-23
Engine hood	11-8	Recommended fluid	11-24
Engine compartment overview.....	11-10	Brake fluid.....	11-24
STI.....	11-10	Checking the fluid level.....	11-24
Except STI	11-11	Recommended brake fluid	11-25
Engine oil.....	11-12	Clutch fluid (MT models).....	11-25
Engine oil consumption.....	11-12	Checking the fluid level.....	11-25
Checking the oil level.....	11-12	Recommended clutch fluid.....	11-26
Changing the oil and oil filter.....	11-14	Brake booster	11-26
Recommended grade and viscosity	11-15	Brake pedal.....	11-27
Synthetic oil.....	11-15	Checking the brake pedal free play	11-27
Cooling system	11-16	Checking the brake pedal reserve distance.....	11-27
Cooling fan, hose and connections.....	11-16	Clutch pedal (MT models).....	11-27
Engine coolant.....	11-17	Checking the clutch function.....	11-27
Air cleaner element.....	11-18	Checking the clutch pedal free play.....	11-28
Replacing the air cleaner element.....	11-18	Hill start assist system.....	11-28
Spark plugs	11-20	Replacement of brake pad and lining	11-28
Recommended spark plugs	11-20	Breaking-in of new brake pads and linings	11-29
Drive belts	11-21	Parking brake stroke	11-29
Manual transmission oil	11-22	Tires and wheels.....	11-30
Recommended grade and viscosity	11-22	Types of tires.....	11-30
		Tire pressure monitoring system (TPMS) (if equipped).....	11-30
		Tire inspection.....	11-31

Tire pressures and wear	11-32	Installation of accessories	11-43
Wheel balance.....	11-34	Replacing bulbs.....	11-43
Wear indicators	11-34	Headlights (models with LED headlights).....	11-43
Tire rotation direction mark	11-35	High beam headlight.....	11-43
Tire rotation	11-35	Low beam headlight (models without LED headlights), front side marker light (if equipped), parking light (models without LED headlights) and front turn signal light.....	11-45
Tire replacement	11-35	Front fog light (if equipped).....	11-46
Wheel replacement.....	11-36	Rear combination lights	11-47
Aluminum wheels.....	11-37	License plate light	11-48
Windshield washer fluid	11-37	Other bulbs	11-48
Replacement of wiper blades	11-38	Battery replacement	11-49
Windshield wiper blade assembly	11-39	Replacing access key battery.....	11-49
Windshield wiper blade rubber	11-39	Replacing transmitter battery	11-50
Battery.....	11-40		
Fuses	11-41		

Maintenance schedule

The scheduled maintenance items required to be serviced at regular intervals are shown in the "Warranty and Maintenance Booklet".

For details of your maintenance schedule, read the separate "Warranty and Maintenance Booklet".

NOTE

For models with a multi function display, you can set a reminder to be displayed when a scheduled maintenance item is almost due. For details, refer to "Maintenance settings" 3-78.

Maintenance precautions

When maintenance and service are required, it is recommended that all work be done by an authorized SUBARU dealer.

If you perform maintenance and service by yourself, you should familiarize yourself with the information provided in this section on general maintenance and service for your SUBARU.

Incorrect or incomplete service could cause improper or unsafe vehicle operation. Any problems caused by improper maintenance and service performed by you are not eligible for warranty coverage.



WARNING

- **Testing of an All-Wheel Drive model must NEVER be performed on a single two-wheel dynamometer or similar apparatus. Attempting to do so will result in transmission damage and in uncontrolled vehicle movement and may cause an accident or injuries to persons nearby.**
- **Always select a safe area when performing maintenance on your vehicle.**

- **Always be very careful to avoid injury when working on the vehicle. Remember that some of the materials in the vehicle may be hazardous if improperly used or handled, for example, battery acid.**
- **Your vehicle should only be serviced by persons fully competent to do so. Serious personal injury may result to persons not experienced in servicing vehicles.**
- **Always use the proper tools and make certain that they are well maintained.**
- **Never get under the vehicle supported only by a jack. Always use safety stands to support the vehicle.**
- **Never keep the engine running in a poorly ventilated area, such as a garage or other closed areas.**
- **Do not smoke or allow open flames around the fuel or battery. This will cause a fire.**
- **Because the fuel system is under pressure, replacement of the fuel filter should be performed only by your SUBARU dealer.**
- **Wear adequate eye protection to**

guard against getting oil or fluids in your eyes. If something does get in your eyes, thoroughly wash them out with clean water.

- Do not tamper with the wiring of the SRS airbag system or seatbelt pretensioner system, or attempt to take its connectors apart, as that may activate the system or it can render it inoperative. NEVER use a circuit tester for this wiring. If your SRS airbag or seatbelt pretensioner needs service, consult your nearest SUBARU dealer.

NOTE

SUBARU does not endorse the use of non-SUBARU approved flushing systems and strongly advises against performing these services on a SUBARU vehicle. Non-SUBARU approved flushing systems use chemicals and/or solvents which have not been tested or approved by SUBARU. SUBARU warranties do not cover any part of the vehicle which is damaged by adding or applying chemicals and/or solvents other than those approved or recommended by SUBARU.

■ Before checking or servicing in the engine compartment

⚠ WARNING

- Always stop the engine and set the parking brake firmly to prevent the vehicle from moving.
- Always let the engine cool down. Engine parts become very hot when the engine is running and remain hot for some time after the engine has stopped.
- Do not spill engine oil, engine coolant, brake fluid or any other fluid on hot engine components. This may cause a fire.
- Always remove the key from the ignition switch or turn the push-button ignition switch to the "OFF" position. When the ignition switch is in the "ON" position, the cooling fan may operate suddenly even when the engine is stopped.
- Before performing any servicing on a vehicle equipped with a remote engine start system (a dealer option) temporarily place that system in the service mode to prevent it from unexpectedly

starting the engine.

■ When checking or servicing in the engine compartment

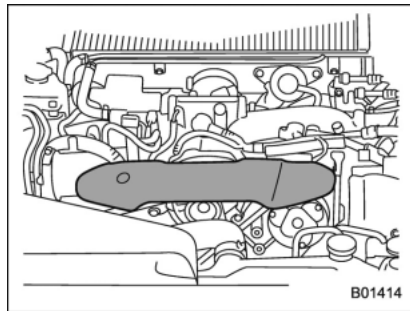

B01414

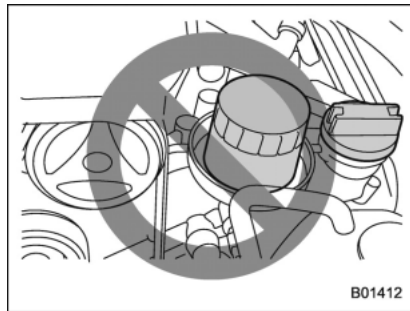

B01412

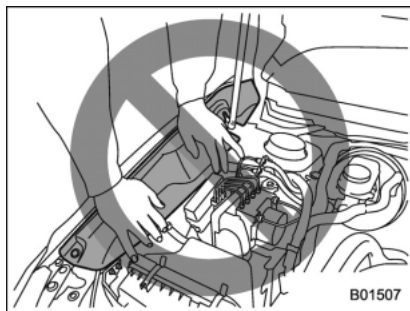

CAUTION

- Do not contact the drive belt cover while checking the components in the engine compartment. Doing so may cause your hand to slip off the cover and result in an unexpected injury.
- Do not touch the oil filter until the engine has cooled down completely. Doing so may result in a burn or other injury. Note that the oil filter becomes very hot when the engine is running and remains hot for some time after the engine has stopped.
- Do not apply force on the fender insulator by placing your hands

on it, etc. Deformation of the insulator and its mount may occur.

- **When checking or servicing in the engine compartment while the engine is running**

WARNING

A running engine can be dangerous. Keep your fingers, hands, clothing, hair and tools away from the cooling fan, drive belt and any other moving engine parts. Removing rings, watches and ties is advisable.

Maintenance tips

Some clips and fender linings must be removed before replacing the air cleaner elements or specific bulbs.

- **Removing and reinstalling clips**

▼ **Removing clips**

There are several types of clips used for your vehicle.

▽ **Type A clips**

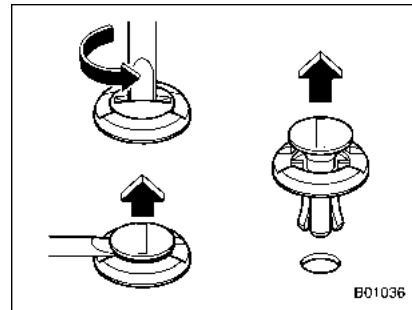

1. Turn the clips counterclockwise using a flat-head screwdriver until the center portion of the clip is raised.
2. Remove the clips with a flat-head screwdriver using leverage.

– CONTINUED –

3. Remove the entire clip by pulling it up.

▽ Type B clips

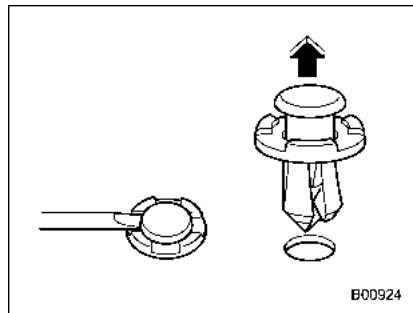

▽ Type C clips

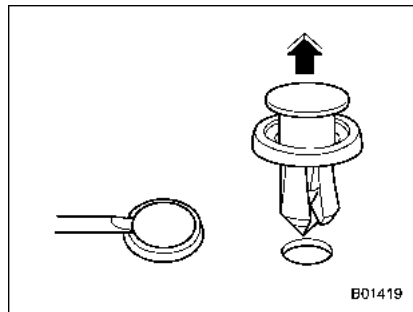

1. Pull out the center portion of the clip

using a flat-head screwdriver as shown in the illustration.

2. Pull the protruded center portion to remove the entire body of the clip.

▽ Type D clips

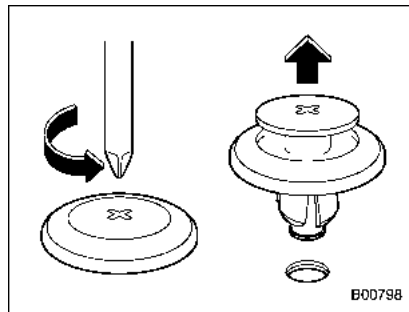

1. Turn the clip counterclockwise using a Phillips screwdriver until the center portion of the clip is raised.

2. Remove the entire clip by pulling it up.

▽ Type E clips

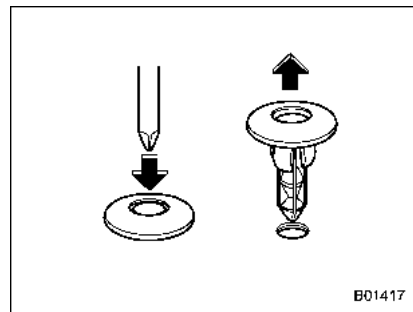

1. Push the center portion of the clip using a Phillips screwdriver until the clip is raised.

2. Remove the entire clip by pulling it up.

▽ Type F clips

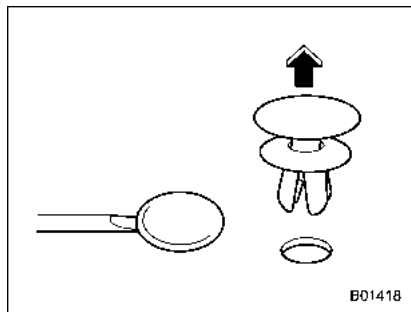

1. Pull out the head of the clip using a flat-head screwdriver as shown in the illustration.
2. Remove the entire clip by pulling it up.

▼ Reinstalling clips

▽ Type A clips

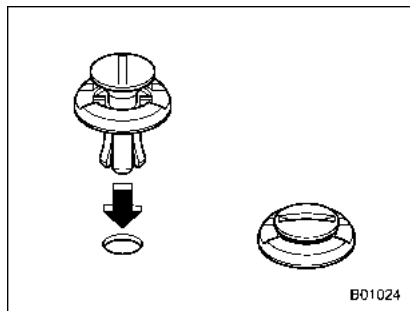

▽ Type B clips

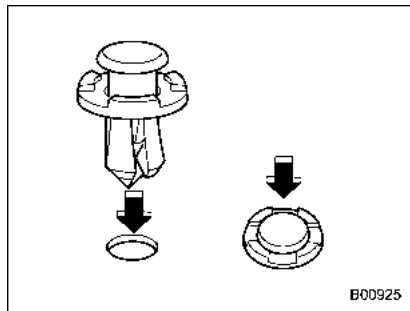

▽ Type C clips

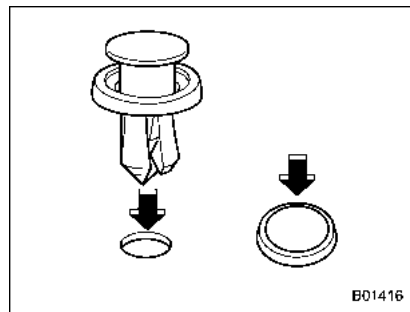

▽ Type D clips

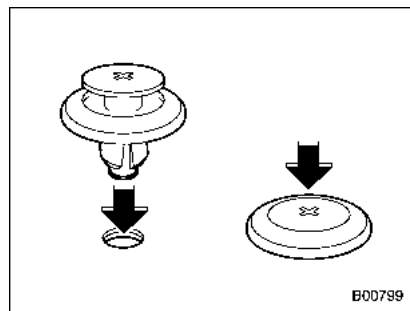

▽ Type E clips

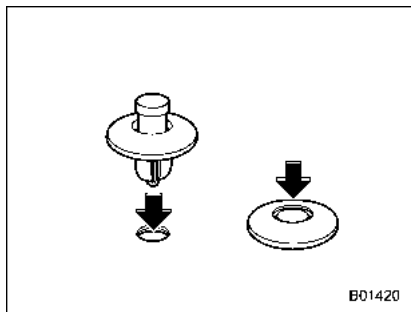

Insert the clip without the center portion first and then push the center portion of the clip into the hole.

▽ Type F clips

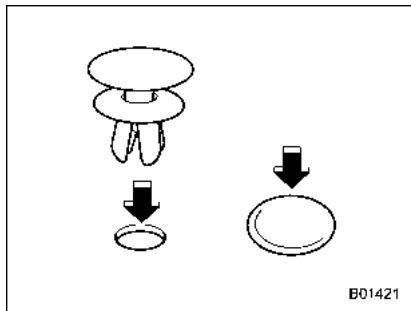

Insert the clip without the head first and then push the head of the clip into the hole.

Engine hood

To open the hood:

1. If the wiper blades are lifted off the windshield, return them to their original position.

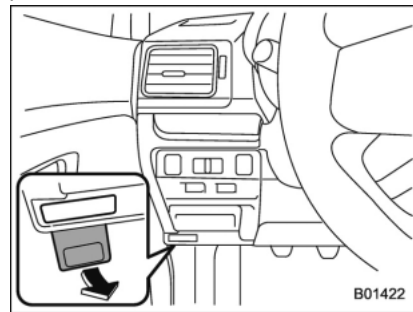

2. Pull the hood release knob under the instrument panel.

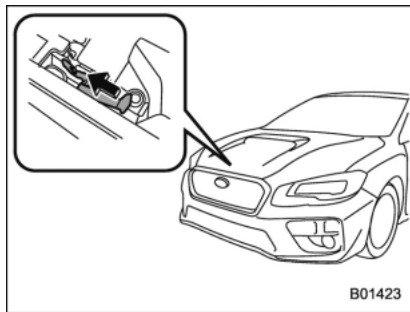

3. Release the secondary hood release by moving the lever between the front grille and the hood toward the left.
4. Lift up the hood.

To close the hood:

1. Lower the hood to a height of approximately 11.8 in (30 cm) above its closed position and then let it drop.
2. After closing the hood, be sure the hood is securely locked.

If this does not close the hood, release it from a slightly higher position. Do not push the hood forcibly to close it. It could deform the metal.

WARNING

Always check that the hood is properly locked before you start driving. If it is not, it might fly open while the vehicle is moving and block your view, which may cause an accident and serious bodily injury.

Engine compartment overview

■ STI

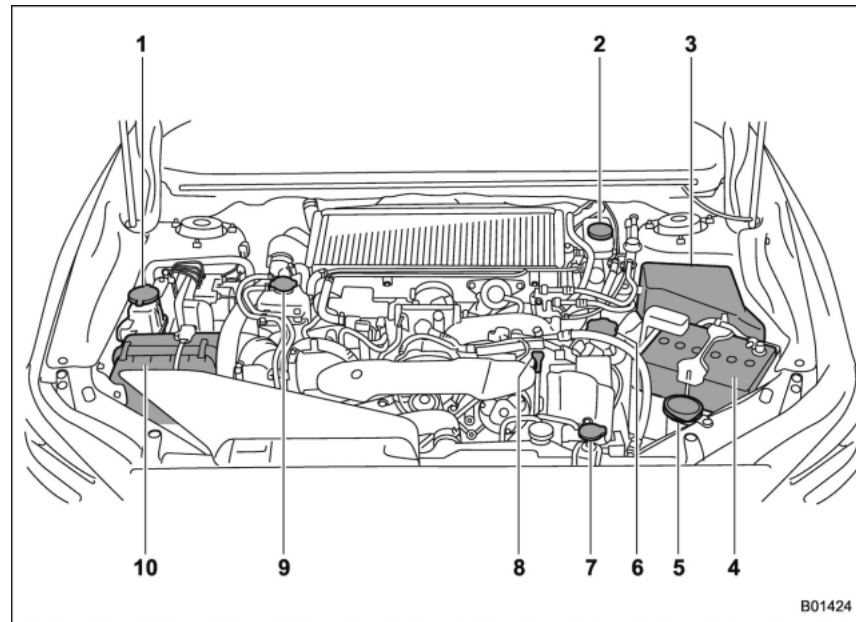

- 1) Power steering fluid reservoir (page 11-23)
- 2) Brake fluid reservoir/Clutch fluid reservoir (page 11-24)
- 3) Fuse box (page 11-41)
- 4) Battery (page 11-40)
- 5) Windshield washer tank (page 11-37)
- 6) Engine oil filler cap (page 11-12)
- 7) Engine coolant reservoir (page 11-17)
- 8) Engine oil level gauge (page 11-12)
- 9) Coolant filler tank cap (page 11-17)
- 10) Air cleaner case (page 11-18)

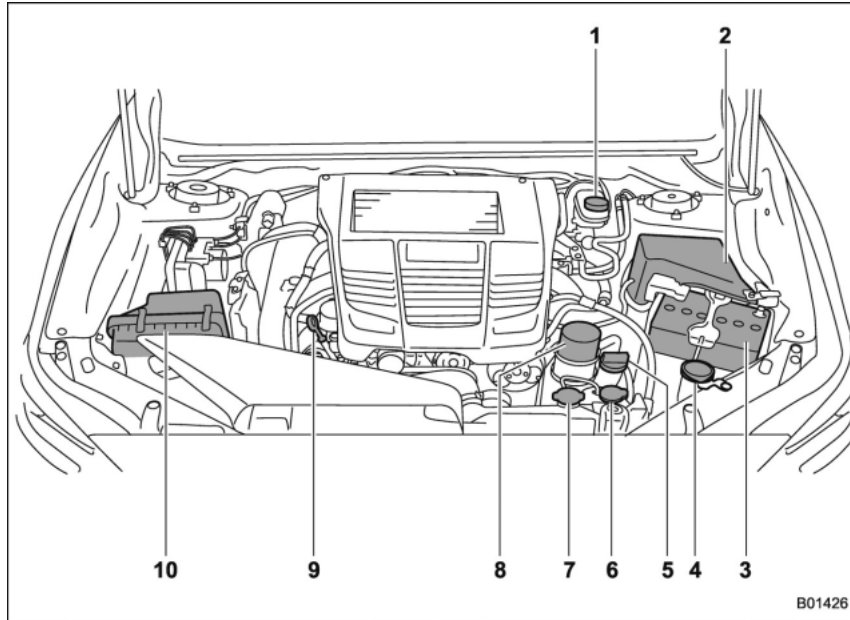
■ Except STI

- 1) Brake fluid reservoir/Clutch fluid reservoir (MT models) (page 11-24)
- 2) Fuse box (page 11-41)
- 3) Battery (page 11-40)
- 4) Windshield washer tank (page 11-37)
- 5) Engine oil filler cap (page 11-12)
- 6) Engine coolant reservoir (page 11-17)
- 7) Radiator cap (page 11-17)
- 8) Engine oil filter (page 11-14)
- 9) Engine oil level gauge (page 11-12)
- 10) Air cleaner case (page 11-18)

B01426

Engine oil

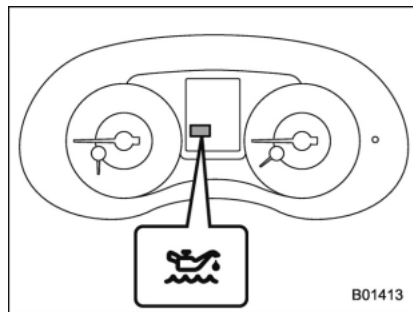

NOTE

For models except STI, when the engine low oil level warning indicator appears, have your vehicle inspected by your SUBARU dealer as soon as possible.

■ Engine oil consumption

Some engine oil will be consumed while driving. Under the following conditions, oil consumption can be increased and thus require refilling between maintenance intervals:

- When the engine is new and within the break-in period
- When the engine oil is of lower quality

- When the incorrect oil viscosity is used
- When engine braking is employed
- When the engine is operated at high engine speeds
- When the engine is operated under heavy loads
- When the engine idles for long periods of time
- When the vehicle is operated in stop and go and/or heavy traffic situations
- When the vehicle is used under severe thermal conditions
- When the vehicle accelerates and decelerates frequently

Under these or similar conditions, you should check your oil at least every 2nd fuel fill-up and change your engine oil more frequently. If your oil consumption rate is greater than 1 quart every 1,200 miles or 1 liter every 2,000 kilometers, contact your SUBARU dealer who may perform a test under controlled conditions.

■ Checking the oil level

Check the engine oil level at each fuel stop.

1. Park the vehicle on a level surface and stop the engine. If you check the oil level just after stopping the engine, wait a few minutes for the oil to drain back into the oil

pan before checking the level.

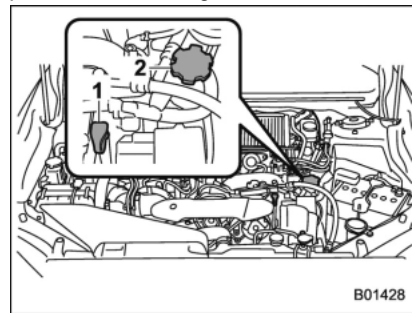

STI

- 1) Oil level gauge
- 2) Oil filler cap

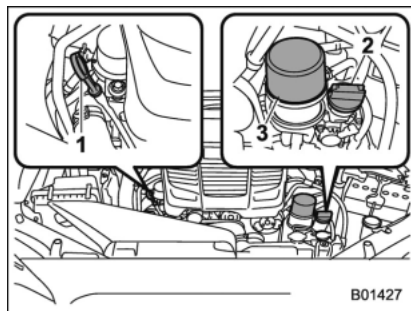
**Except STI**

- 1) Oil level gauge
- 2) Oil filler cap
- 3) Oil filter

2. Pull out the level gauge, wipe it clean, and insert it again.
3. Be sure the level gauge is correctly inserted until it stops.

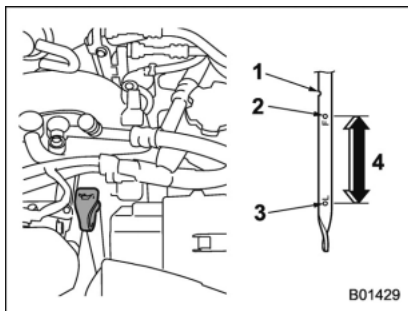
**STI**

- 1) Notch
- 2) Full level
- 3) Low level
- 4) Approximately 1.1 US qt (1.0 liter, 0.9 Imp qt) from low level to full level

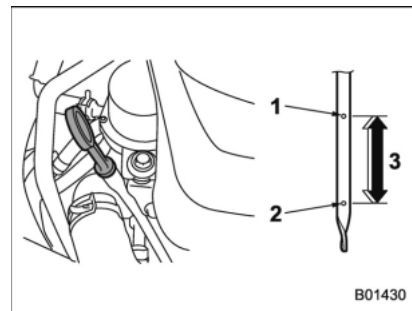
**Except STI**

- 1) Full level
- 2) Low level
- 3) Approximately 1.1 US qt (1.0 liter, 0.9 Imp qt) from low level to full level

4. Pull out the oil level gauge again.
5. **STI:**

Check the oil level on the gauge. If the oil level is below the low level mark, add oil so that the full level is reached.

Except STI:

Check the oil levels on both sides of the level gauge. The engine oil level must be judged by the lowest of the two levels. If the oil level is below the low level mark, add oil so that the full level is reached.

CAUTION

- For models except STI, be careful not to touch the engine oil filter when removing the oil filler cap. Doing so may result in a burn, a pinched finger, or may cause some other injury.
- Use only engine oil with the recommended grade and viscosity.
- Be careful not to spill engine oil when adding it. If oil touches the exhaust pipe, it may cause a bad smell, smoke, and/or a fire. If engine oil gets on the exhaust pipe, be sure to wipe it off.
- If the level gauge is not pulled out easily, twist the level gauge right and left, then pull it out. Otherwise, you may be injured accidentally straining yourself.

To add engine oil, remove the engine oil filler cap and slowly pour engine oil through the filler neck. After pouring oil into the engine, you must use the level gauge to confirm that the oil level is correct.

For models STI, just after driving or while the engine is warm, the engine oil level

reading may be in a range between the upper level and the notch mark. This is caused by thermal expansion of the engine oil.

NOTE

To prevent overfilling the engine oil, do not add any additional oil above the upper level when the engine is cold.

Changing the oil and oil filter

CAUTION

If you change your own oil, be sure to drain all the oil from the filter before disposal. Do not dispose of used engine oil by placing it in the trash, or by pouring it onto the ground, into sewers, or into any body of water. Check with your local government office for the proper disposal options available to you.

Change the oil and oil filter according to the maintenance schedule in the "Warranty and Maintenance Booklet".

The engine oil and oil filter must be changed more frequently than listed in the maintenance schedule when driving on dusty roads, when short trips are frequently made, or when driving in extremely cold weather.

Changing the oil filter

It may be difficult to change the oil filter. Have the oil filter changed by your SUBARU dealer if necessary.

Changing the oil

1. Warm up the engine by letting the engine idle for approximately 10 minutes to ease draining the engine oil.
2. Park the vehicle on a level surface and stop the engine.
3. Remove the oil filler cap.

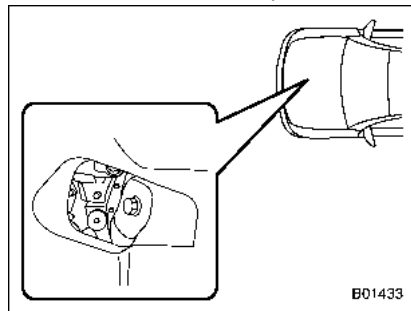

B01433

STI

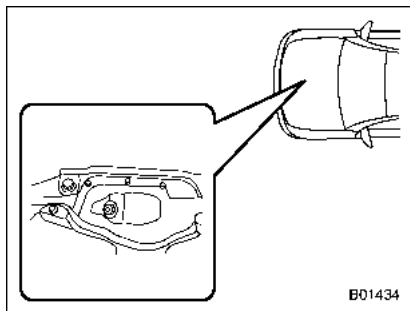

Except STI

4. Drain out the engine oil by removing the drain plug while the engine is still warm. The used oil should be drained into an appropriate container and disposed of properly.

WARNING

Be careful not to burn yourself with hot engine oil.

5. Wipe the seating surface of the drain plug with a clean cloth and tighten it securely with a new sealing washer after the oil has completely drained out.

CAUTION

Thoroughly wipe off any engine oil

that has spilled over the exhaust pipe and/or under-cover. If spilled oil is not promptly wiped up, the oil could cause a fire.

6. Pour engine oil through the filler neck. For the oil capacity (guideline), refer to "Engine oil" 12-4.

The oil quantity indicated above is only guideline.

The necessary quantity of oil depends on the quantity of oil that has been drained. The quantity of drained oil differs slightly depending on the temperature of the oil and the time the oil is left flowing out. After refilling the engine with oil, therefore, you must use the level gauge to confirm that the level is correct.

7. Start the engine and make sure that no oil leaks appear around the drain plug.

8. Run the engine until it reaches the normal operating temperature. Then stop the engine and wait a few minutes to allow the oil drain back. Check the oil level again and if necessary, add more engine oil.

CAUTION

Be careful not to spill engine oil when adding it. If oil touches the

exhaust pipe, it may cause a bad smell, smoke, and/or a fire.

Recommended grade and viscosity

CAUTION

Use only engine oil with the recommended grade and viscosity.

Refer to "Engine oil" 12-4.

NOTE

Engine oil viscosity (thickness) affects fuel economy. Oils of lower viscosity provide better fuel economy. However, in hot weather, oil of higher viscosity is required to properly lubricate the engine.

Synthetic oil

You must follow the oil and filter changing intervals shown in the Warranty and Maintenance booklet.

NOTE

Synthetic oil of the grade and viscosity noted in chapter 12 is the recommended engine oil for optimum engine performance. Conventional oil may be

used if synthetic oil is unavailable.

Cooling system



WARNING

- Never attempt to remove the radiator cap until the engine has been shut off and has cooled down completely. Since the coolant is under pressure, you may suffer serious burns from a spray of boiling hot coolant when the cap is removed.
- Be careful of the rotating cooling fan when the engine hood is open. When the engine temperature is high, the cooling fan in the engine compartment may operate when the ignition switch is turned to the "ON" position, even if the engine is stopped. Touching the cooling fan while it is rotating may result in injury.



CAUTION

- Vehicles are filled at the factory with SUBARU Super Coolant that does not require the first change for 11 years/137,500 miles (11 years/220,000 km). This coolant should not be mixed with any

other brand or type of coolant during this period. Mixing with a different coolant will reduce the life of the coolant. Should it be necessary to top up the coolant for any reason, use only SUBARU Super Coolant.

If the SUBARU Super Coolant is diluted with another brand or type, the maintenance interval is shortened to that of the mixing coolant.

- Do not splash the engine coolant over painted parts. The alcohol contained in the engine coolant may damage the paint surface.

■ Cooling fan, hose and connections

Your vehicle employs an electric cooling fan which is thermostatically controlled to operate when the engine coolant reaches a specific temperature.

If the radiator cooling fan does not operate even when the engine coolant temperature gauge exceeds the normal operating range, the cooling fan circuit may be defective. Refer to "Temperature gauge" 3-11.

Check the fuse and replace it if necessary. Refer to "Fuses" 11-41 and "Fuses and circuits" 12-9.

If the fuse is not blown, have the cooling system checked by your SUBARU dealer.

If frequent addition of coolant is necessary, there may be a leak in the engine cooling system. It is recommended that the cooling system and connections be checked for leaks, damage, or looseness.

■ Engine coolant

▼ Checking the coolant level

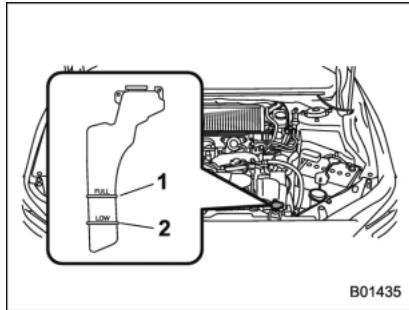

- 1) "FULL" level mark
- 2) "LOW" level mark

Check the coolant level at each fuel stop.

1. Check the coolant level on the outside

of the reservoir while the engine is cool.

2. If the level is close to or lower than the "LOW" level mark, add coolant up to the "FULL" level mark. If the reserve tank is empty, remove the radiator cap and refill coolant up to just below the filler neck as shown in the following illustration.

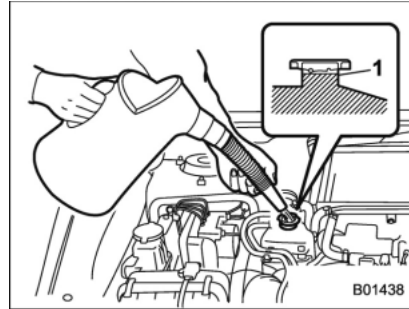

STI

- 1) Fill up to this level

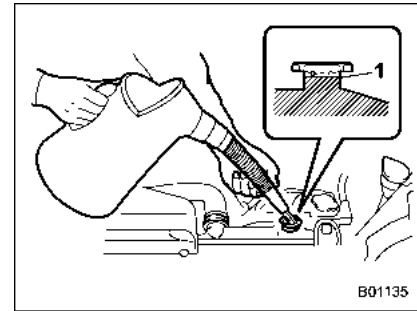

Except STI

- 1) Fill up to this level

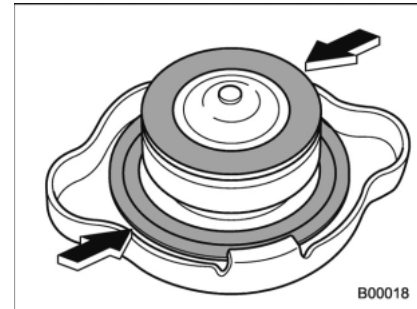

3. After refilling the reserve tank and the radiator, reinstall the cap and check that the rubber gaskets inside the radiator cap are in the proper position.

CAUTION

- Be careful not to spill engine coolant when adding it. If coolant touches the exhaust pipe, it may cause a bad smell, smoke, and/or a fire. If engine coolant gets on the exhaust pipe, be sure to wipe it off.
- Do not splash the engine coolant over painted parts. The alcohol contained in the engine coolant may damage the paint surface.

▼ **Changing the coolant**

It may be difficult to change the coolant. Have the coolant changed by your SUBARU dealer if necessary.

The coolant should be changed according to the maintenance schedule in the "Warranty and Maintenance Booklet".

Air cleaner element

WARNING

Do not operate the engine with the air cleaner element removed. The air cleaner element not only filters intake air but also stops flames if the engine backfires. If the air cleaner element is not installed when the engine backfires, you could be burned.

CAUTION

When replacing the air cleaner element, use a genuine SUBARU air cleaner element. If it is not used, there is the possibility of causing a negative effect to the engine.

The air cleaner element functions as a filter screen. When the element is perforated or removed, engine wear will be excessive and engine life shortened.

It is not necessary to clean or wash the air cleaner element.

■ **Replacing the air cleaner element**

Replace the air cleaner element according to the maintenance schedule in the "Warranty and Maintenance Booklet". Under extremely dusty conditions, replace it more frequently. It is recommended that you always use genuine SUBARU parts.

▼ **STI**

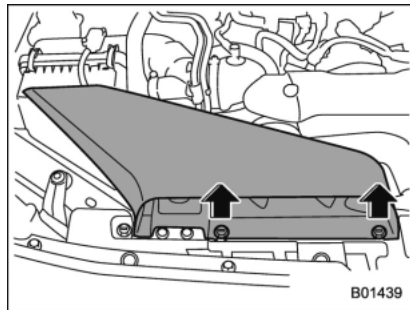

1. Use a screwdriver to undo the clips on the air intake duct, then remove the air intake duct.

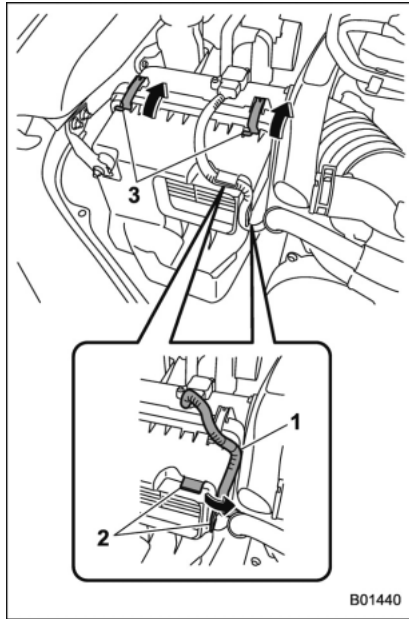

- 1) Connector cable
- 2) Guides
- 3) Clips

2. Remove the connector cable from the guides of the air cleaner case.
3. Unsnap the two clips holding the air

cleaner case cover.

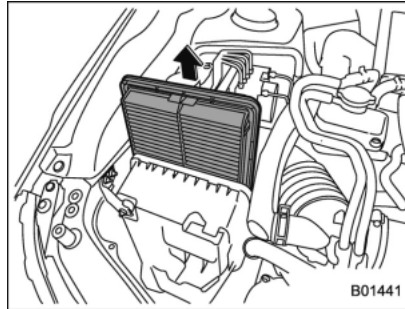

4. Open the air cleaner case and remove the air cleaner element.
5. Clean the inside of the air cleaner case and case cover with a damp cloth and install a new air cleaner element.
6. Install the removed or loosened parts in the reverse order of removal.

▼ **Except STI**

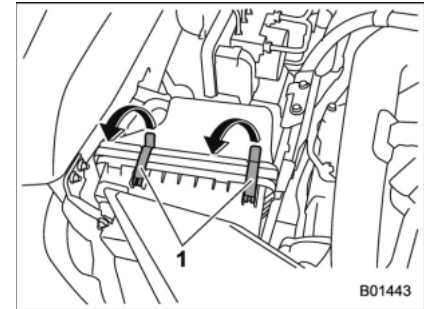

- 1) Clips
1. Unsnap the two clips holding the air cleaner case cover.

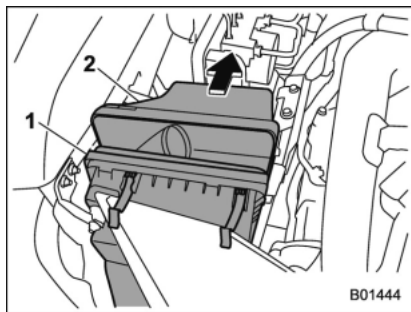

- 1) Air cleaner case
- 2) Air cleaner case cover

2. Open the air cleaner case and pull the cover rearward while lifting it up.

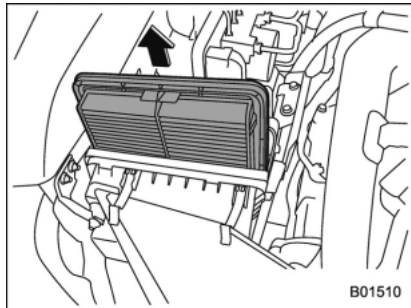

3. Remove the air cleaner element.

4. Clean the inside of the air cleaner case and case cover with a damp cloth and install a new air cleaner element.

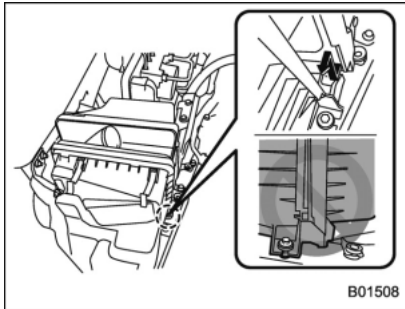

5. To install the air cleaner case cover, insert the projections on the air cleaner case cover into the slits on the air cleaner case. The illustration above shows an example in which the projections are not fitted into the slits correctly.

6. Install in the reverse order of removal.

Spark plugs

It may be difficult to replace the spark plugs. It is recommended that you have the spark plugs replaced by your SUBARU dealer.

The spark plugs should be replaced according to the maintenance schedule in the "Warranty and Maintenance Booklet".

■ Recommended spark plugs

For the recommended spark plugs, refer to "Electrical system" 12-8.

Drive belts

NOTE

For models except STI, it is unnecessary to check the deflection of the drive belt periodically because this engine is equipped with an automatic belt tension adjuster. However, replacement of the belt should be done according to the maintenance schedule in the "Warranty and Maintenance Booklet". Consult your SUBARU dealer for replacement.

If the drive belt is loose, cracked or worn, contact your SUBARU dealer.

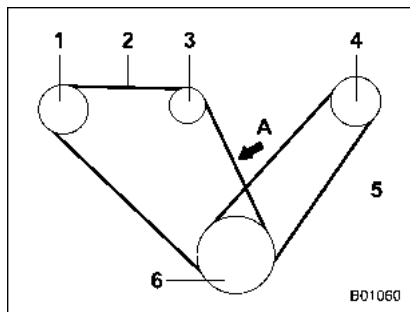

STI

- 1) Power steering oil pump pulley
 - 2) Front side belt
 - 3) Alternator pulley
 - 4) Air conditioner compressor pulley
 - 5) Rear side belt
 - 6) Crank pulley
- A) 22 lbf (98 N, 10 kgf)

CAUTION

The front side belt, which runs in conjunction with the following components, must be used within the specified deflection.

- Power steering oil pump pulley
- Alternator pulley
- Crank pulley

Check the deflection of the front

side belt and if there is any looseness, cracks, wear or unusual noise on the front side belt, contact your SUBARU dealer.

Continuing to use the vehicle with the belt outside of the specification may cause the engine to malfunction and the above components to malfunction.

To check the deflection of the front side belt, place a straightedge (ruler) across two adjacent pulleys (alternator pulley and crank pulley) and apply a force of 22 lbf (98 N, 10 kgf) midway between the pulleys by using a spring scale. The belt deflection should be the amount specified. If the front side belt is loose, cracked or worn, contact your SUBARU dealer.

	Deflection	
	New belt	Used belt
A	0.28 – 0.35 (7.0 – 9.0)	0.35 – 0.43 (9.0 – 11.0)

The rear side belt is a stretch-type belt, therefore the deflection does not need to be checked. If there are cracks or wear confirmed on the belts and a squeaking noise is heard from them, contact your SUBARU dealer.

Manual transmission oil

It is not necessary to check the transmission oil level. Check that there are no cracks, damage or leakage. However, the oil inspection should be performed according to the maintenance schedule in the "Warranty and Maintenance Booklet". Consult your SUBARU dealer for details.

■ Recommended grade and viscosity

Each oil manufacturer has its own base oils and additives. Never use different brands together. For details, refer to "Manual transmission, front differential and rear differential gear oil" ☞12-6.

Continuously variable transmission fluid

It is not necessary to check the transmission fluid level. Check that there are no cracks, damage or leakage. However, the fluid inspection should be performed according to the maintenance schedule in the "Warranty and Maintenance Booklet". Consult your SUBARU dealer for details.

Front differential gear oil (CVT models)

It is not necessary to check the gear oil level. Check that there are no cracks, damage or leakage. However, the oil inspection should be performed according to the maintenance schedule in the "Warranty and Maintenance Booklet". Consult your SUBARU dealer for details.

■ Recommended grade and viscosity

Each oil manufacturer has its own base oils and additives. Never use different brands together. For details, refer to "Manual transmission, front differential and rear differential gear oil" ☞12-6.

Rear differential gear oil

It is not necessary to check the gear oil level. Check that there are no cracks, damage or leakage. However, the oil inspection should be performed according to the maintenance schedule in the "Warranty and Maintenance Booklet". Consult your SUBARU dealer for details.

■ Recommended grade and viscosity

Each oil manufacturer has its own base oils and additives. Never use different brands together. For details, refer to "Manual transmission, front differential and rear differential gear oil" 12-6.



CAUTION

Using a differential gear oil other than the specified oil may cause a decline in vehicle performance.

Power steering fluid (STI)

■ Checking the fluid level

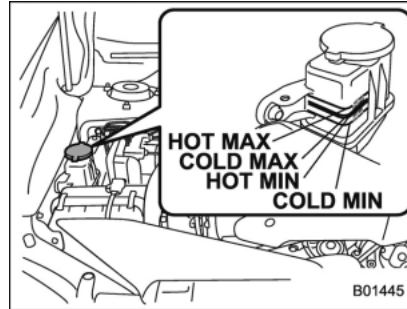

The power steering fluid expands greatly as its temperature rises; the fluid level differs according to fluid temperature. Therefore, the reservoir tank has two different checking ranges for hot and cold fluids.

Check the power steering fluid level monthly.

1. Park the vehicle on a level surface, and stop the engine.
2. Check the fluid level of the reservoir tank.

When the fluid is hot after the vehicle has been run: Check that the oil level is between "HOT MIN" and "HOT MAX" on

the surface of the reservoir tank.

When the fluid is cool before the vehicle is run: Check that the oil level is between "COLD MIN" and "COLD MAX" on the surface of the reservoir tank.

3. If the fluid level is lower than the applicable "MIN" line, add the recommended fluid as necessary to bring the level between the "MIN" and "MAX" line.

If the fluid level is extremely low, it may indicate possible leakage. Consult your SUBARU dealer for an inspection.



WARNING

Be careful not to burn yourself because the fluid may be hot.



CAUTION

- When power steering fluid is being added, use only clean fluid, and be careful not to allow any dirt into the tank. And never use different brands together.
- Be careful not to spill power steering fluid when adding it. If power steering fluid touches the exhaust pipe, it may cause a bad smell, smoke, and/or a fire. If power steering fluid gets on the

exhaust pipe, be sure to wipe it off.

■ Recommended fluid

Refer to "Fluids" 12-7.

Brake fluid

■ Checking the fluid level

WARNING

- Never let brake fluid contact your eyes because brake fluid can be harmful to your eyes. If brake fluid gets in your eyes, immediately flush them thoroughly with clean water. For safety, when performing this work, wearing eye protection is advisable.
- Brake fluid absorbs moisture from the air. Any absorbed moisture can cause a dangerous loss of braking performance.
- If the vehicle requires frequent refilling, there may be a leak. If you suspect a problem, have the vehicle checked at your SUBARU dealer.

CAUTION

- When adding brake fluid, be careful not to allow any dirt into the reservoir.
- Never splash the brake fluid over painted surfaces or rubber parts.

Alcohol contained in the brake fluid may damage them.

- Be careful not to spill brake fluid when adding it. If brake fluid touches the exhaust pipe, it may cause a bad smell, smoke, and/or a fire. If brake fluid gets on the exhaust pipe, be sure to wipe it off.

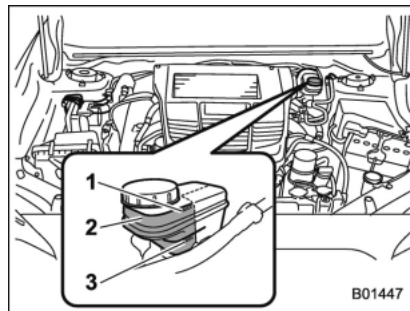

- 1) "MAX" level line
- 2) The brake fluid level must be checked in this area.
- 3) "MIN" level line

Check the fluid level monthly.

Check the fluid level on the outside of the reservoir. Because this reservoir is used for both the brake and clutch systems and has chambers for each system, be sure to

check the fluid level for the brake system at the **front part of the reservoir** (shaded area in the illustration). If the fluid level is below "MIN", add the recommended brake fluid to "MAX".

Use only brake fluid from a sealed container.

■ Recommended brake fluid

Refer to "Fluids" 12-7.

CAUTION

Never use different brands of brake fluid together. Also, avoid mixing DOT 3 and DOT 4 brake fluids even if they are the same brand.

Clutch fluid (MT models)

■ Checking the fluid level

WARNING

Never let clutch fluid contact your eyes because clutch fluid can be harmful to your eyes. If clutch fluid gets in your eyes, immediately flush them thoroughly with clean water. For safety, when performing this work, wearing eye protection is advisable.

CAUTION

- Clutch fluid absorbs moisture from the air. Any absorbed moisture can cause improper clutch operation.
- If the vehicle requires frequent refilling, there may be a leak. If you suspect a problem, have the vehicle checked at your SUBARU dealer.
- When clutch fluid is added, be careful not to allow any dirt into the tank.
- Never splash the clutch fluid over painted surfaces or rubber parts.

Alcohol contained in the clutch fluid may damage them.

- Be careful not to spill clutch fluid when adding it. If clutch fluid touches the exhaust pipe, it may cause a bad smell, smoke, and/or a fire. If clutch fluid gets on the exhaust pipe, be sure to wipe it off.
- The fluid level for the clutch system must be checked at the inboard side of the reservoir. It cannot be checked at the outboard side of the reservoir.

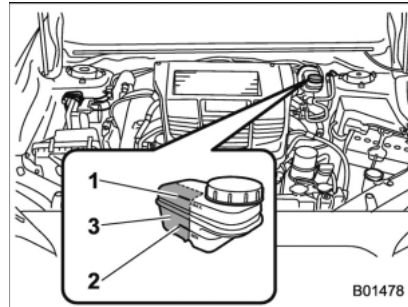

- 1) "MAX" level line
- 2) The clutch fluid level must be checked in this area.
- 3) "MIN" level line

Check the fluid level monthly.

Check the fluid level on the outside of the reservoir. Because this reservoir is used for both the brake and clutch systems and has chambers for each system, be sure to check the fluid level for the clutch system at the **inboard side of the reservoir** (shaded area in the illustration). If the fluid level is below "MIN", add the recommended clutch fluid to "MAX".

Use only clutch fluid from a sealed container.

■ Recommended clutch fluid

Refer to "Fluids" 12-7.



CAUTION

Never use different brands of clutch fluid together. Also, avoid mixing DOT 3 and DOT 4 brake fluids even if they are the same brand.

Brake booster

If the brake booster does not operate as described in the following, have it checked by your SUBARU dealer.

1. With the engine off, depress the brake pedal several times, applying the same pedal force each time. The distance the pedal travels should not vary.
2. With the brake pedal depressed, start the engine. The pedal should move slightly down to the floor.
3. With the brake pedal depressed, stop the engine and keep the pedal depressed for 30 seconds. The pedal height should not change.
4. Start the engine again and run for approximately one minute then turn it off. Depress the brake pedal several times to check the brake booster. The brake booster operates properly if the pedal stroke decreases with each depression.

NOTE

When you depress the brake pedal strongly or suddenly, you might feel that lighter depression of the brake pedal generates a greater braking force. However, even though these occur, they do not indicate any malfunctions, and the brake assist system

is operating properly.

Brake assist is not a system that brings more braking ability to the vehicle beyond its breaking capability.

Brake pedal

Check the brake pedal free play and reserve distance according to the maintenance schedule in the "Warranty and Maintenance Booklet".

■ Checking the brake pedal free play

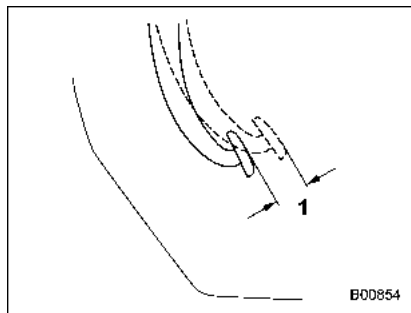

- 1) 0.02 – 0.08 in (0.5 – 2.0 mm)

Stop the engine and firmly depress the brake pedal several times. Lightly pull the brake pedal up with one finger to check the free play with a force of less than 2 lbf (10 N, 1 kgf).

If the free play is not within proper specification, contact your SUBARU dealer.

■ Checking the brake pedal reserve distance

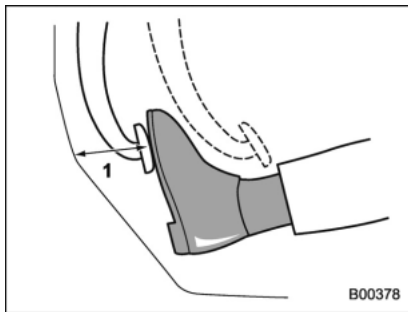

- 1) More than 2.56 in (65 mm)

Depress the pedal with a force of approximately 66 lbf (294 N, 30 kgf) and measure the distance between the upper surface of the pedal pad and the floor.

When the measurement is smaller than the specification, or when the pedal does not operate smoothly, contact with your SUBARU dealer.

Clutch pedal (MT models)

Check the clutch pedal free play and reserve distance according to the maintenance schedule in the "Warranty and Maintenance Booklet".

■ Checking the clutch function

Check the clutch engagement and disengagement.

1. With the engine idling, check that there are no abnormal noises when the clutch pedal is depressed, and that shifting into 1st or reverse feels smooth.
2. Start the vehicle by releasing the pedal slowly to check that the engine and transmission smoothly couple without any sign of slippage.

■ Checking the clutch pedal free play

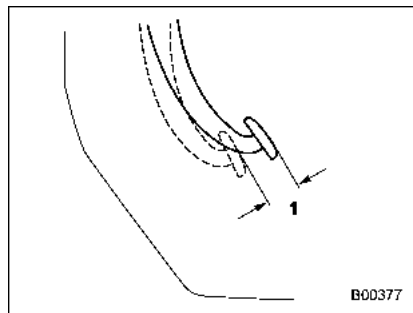

1) 0.16 – 0.43 in (4.0 – 11.0 mm)

Lightly depress the clutch pedal down with your finger until you feel resistance, and check the free play.

If the free play is not within proper specification, contact your SUBARU dealer.

Hill start assist system

Ensure that the Hill start assist system operates properly under the following circumstances.

1. Stop the vehicle on an uphill grade by depressing the brake pedal (all models) and clutch pedal (MT models only), with the engine running.
2. Make sure that the vehicle does not move backward for several seconds after the brake pedal is released.
3. Then make sure the vehicle starts climbing the grade by following the normal starting procedures.

If the Hill start assist system does not operate as described above, contact your SUBARU dealer.

Replacement of brake pad and lining

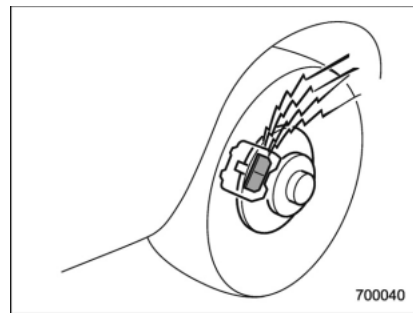

The disc brakes have audible wear indicators on the brake pads. If the brake pads wear close to their service limit, the wear indicator makes a very audible scraping noise when the brake pedal is applied.

If you hear this scraping noise each time you apply the brake pedal, have the brake pads serviced by your SUBARU dealer as soon as possible.



CAUTION

If you continue to drive despite the scraping noise from the audible

brake pad wear indicator, it will result in the need for costly brake rotor repair or replacement.

■ Breaking-in of new brake pads and linings

When replacing the brake pad or lining, use only genuine SUBARU parts. After replacement, the new parts must be broken in as follows.

▼ Brake pad and lining

While maintaining a speed of 30 to 40 mph (50 to 65 km/h), step on the brake pedal lightly. Repeat this five or more times.

▼ Parking brake lining

1. Drive the vehicle at a speed of approximately 22 mph (35 km/h).
2. With the parking brake release button pushed in, pull the parking brake lever SLOWLY and GENTLY (pulling with a force of approximately 33.7 lbf [150 N, 15.3 kgf]).
3. Drive the vehicle for approximately 220 yards (200 meters) in this condition.
4. Wait 5 to 10 minutes for the parking brake to cool down. Repeat this procedure.
5. Check the parking brake stroke. If the

parking brake stroke is out of the specified range, adjust it by turning the adjusting nut located on the parking brake lever.

Parking brake stroke:

7 – 8 notches / 45 lbf (200 N, 20.4 kgf)

WARNING

A safe location and situation should be selected for break-in driving.

CAUTION

Pulling the parking brake lever too forcefully may cause the rear wheels to lock. To avoid this, be certain to pull the lever up slowly and gently.

Parking brake stroke

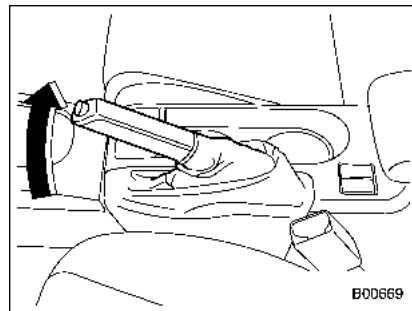

Check the parking brake stroke according to the maintenance schedule in the "Warranty and Maintenance Booklet". When the parking brake is properly adjusted, braking power is fully applied by pulling the lever up 7 to 8 notches gently but firmly (approximately 45 lbf [200 N, 20.4 kgf]). If the parking brake lever stroke is not within the specified range, have the brake system checked and adjusted at your SUBARU dealer.

Tires and wheels

■ Types of tires

You should be familiar with type of tires present on your vehicle.

▼ All season tires

All season tires are designed to provide an adequate measure of traction, handling and braking performance in year-round driving including snowy and icy road conditions. However all season tires do not offer as much traction performance as winter (snow) tires in heavy or loose snow or on icy roads.

All season tires are identified by "ALL SEASON" and/or "M+S" (Mud & Snow) on the tire sidewall.

▼ Summer tires

Summer tires are high-speed capability tires best suited for highway driving under dry conditions.

Summer tires are inadequate for driving on slippery roads such as on snow-covered or icy roads.

If you drive your vehicle on snow-covered or icy roads, we strongly recommend the use of winter (snow) tires.

When installing winter tires, be sure to replace all four tires.

▼ Winter (snow) tires

Winter tires are best suited for driving on snow-covered and icy roads. However winter tires do not perform as well as summer tires and all season tires on roads other than snow-covered and icy roads.

■ Tire pressure monitoring system (TPMS) (if equipped)

The tire pressure monitoring system provides the driver with a warning message by sending a signal from a sensor that is installed in each wheel when tire pressure is severely low. The tire pressure monitoring system will activate only when the vehicle is driven. Also, this system may not react immediately to a sudden drop in tire pressure (for example, a blow-out caused by running over a sharp object).

If you adjust the tire pressures in a warm garage and will then drive the vehicle in cold outside air, the resulting drop in tire pressures may cause the low tire pressure warning light to illuminate. To avoid this problem when adjusting the tire pressures in a warm garage, inflate the tires to pressures higher than those shown on the tire placard. Specifically, inflate them by an extra 1 psi (6.9 kPa, 0.07 kgf/cm²) for every difference of 10°F (5.6°C) between the temperature in the garage and the

temperature outside. By way of example, the following table shows the required tire pressures that correspond to various outside temperatures when the temperature in the garage is 60°F (15.6°C).

Example:

Tire size: 245/40R18 97W

Standard tire pressures:

Front: 33 psi (230 kPa, 2.3 kgf/cm²)

Rear: 32 psi (220 kPa, 2.2 kgf/cm²)

Garage temperature: 60°F (15.6°C)

Outside temperature	Adjusted pressure [psi (kPa, kgf/cm ²)]	
	Front	Rear
30°F (-1°C)	36 (250, 2.5)	35 (240, 2.4)
10°F (-12°C)	38 (260, 2.6)	37 (255, 2.55)
-10°F (-23°C)	40 (275, 2.75)	39 (270, 2.7)

If the low tire pressure warning light illuminates when you drive the vehicle in cold outside air after adjusting the tire pressures in a warm garage, re-adjust the tire pressures using the method described above. Then, increase the vehicle speed to at least 20 mph (32 km/h) and check to see that the low tire pressure warning light turns off a few minutes later. If the low tire pressure warning light does not turn off, the tire pressure monitoring system may not be functioning normally. In this event,

go to a SUBARU dealer to have the system inspected as soon as possible.

While the vehicle is driven, friction between tires and the road surface causes the tires to warm up. After illumination of the low tire pressure warning light, any increase in the tire pressures caused by an increase in the outside air temperature or by an increase in the temperature in the tires can cause the low tire pressure warning light to turn off.

System resetting is necessary when the wheels are changed (for example, a switch to snow tires) and new TPMS valves are installed on the newly fitted wheels. Have this work performed by a SUBARU dealer following wheel replacement.

It may not be possible to install TPMS valves on certain wheels that are on the market. Therefore, if you change the wheels (for example, a switch to snow tires), use wheels that have the same part number as the standard-equipment wheels. Without four operational TPMS valve/sensors on the wheels, the TPMS will not fully function and the warning light on the combination meter will illuminate steadily after blinking for approximately one minute.

When a tire is replaced, adjustments are necessary to ensure continued normal operation of the tire pressure monitoring system. As with wheel replacement, therefore, you should have the work performed by a SUBARU dealer.



WARNING

If the low tire pressure warning light does not illuminate briefly after the ignition switch is turned ON or the light illuminates steadily after blinking for approximately one minute, you should have your Tire Pressure Monitoring System checked at a SUBARU dealer as soon as possible.

If this light illuminates while driving, never brake suddenly and keep driving straight ahead while gradually reducing speed. Then slowly pull off the road to a safe place. Otherwise an accident involving serious vehicle damage and serious personal injury could occur.

If this light still illuminates while driving after adjusting the tire pressure, a tire may have significant damage and a fast leak that causes the tire to lose air rapidly. If you have a flat tire, replace it with a spare tire

as soon as possible.

When a spare tire is mounted or a wheel rim is replaced without the original pressure sensor/transmitter being transferred, the low tire pressure warning light will illuminate steadily after blinking for approximately one minute. This indicates the TPMS is unable to monitor all four road wheels. Contact your SUBARU dealer as soon as possible for tire and sensor replacement and/or system resetting. If the light illuminates steadily after blinking for approximately one minute, promptly contact a SUBARU dealer to have the system inspected.

■ Tire inspection

Check on a daily basis that the tires are free from serious damage, nails, and stones. At the same time, check the tires for abnormal wear.

Contact your SUBARU dealer immediately if you find any problem.

NOTE

- When the wheels and tires strike curbs or are subjected to harsh treatment as when the vehicle is driven on a rough surface, they can suffer damage

that cannot be seen with the naked eye. This type of damage does not become evident until time has passed. Try not to drive over curbs, potholes or on other rough surfaces. If doing so is unavoidable, keep the vehicle's speed down to a walking pace or less, and approach the curbs as squarely as possible. Also, make sure the tires are not pressed against the curb when you park the vehicle.

- If you feel unusual vibration while driving or find it difficult to steer the vehicle in a straight line, one of the tires and/or wheels may be damaged. Drive slowly to the nearest authorized SUBARU dealer and have the vehicle inspected.

■ Tire pressures and wear

Maintaining the correct tire pressures helps to maximize the tires' service lives and is essential for good running performance. Check and, if necessary, adjust the pressure of each tire (including the spare) at least once a month (for example, during a fuel stop) and before any long journey.

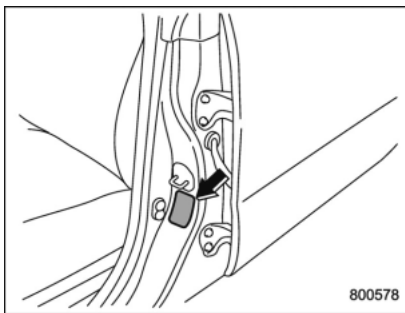

Tire placard

Check the tire pressures when the tires are cold. Use a pressure gauge to adjust the tire pressures to the values shown on the tire placard. The tire placard is located on the door pillar on the driver's side.

Driving even a short distance warms up the tires and increases the tire pressures. Also, the tire pressures are affected by the outside temperature. It is best to check tire pressure outdoors before driving the vehicle.

When a tire becomes warm, the air inside it expands, causing the tire pressure to increase. Be careful not to mistakenly release air from a warm tire to reduce its pressure.

NOTE

- The air pressure in a tire increases by approximately 4.3 psi (30 kPa, 0.3 kgf/cm²) when the tire becomes warm.
- The tires are considered cold when the vehicle has been parked for at least three hours or has been driven less than one mile (1.6 km).



WARNING

Do not let air out of warm tires to adjust pressure. Doing so will result in low tire pressure.

Incorrect tire pressures detract from controllability and ride comfort, and they cause the tires to wear abnormally.

- **Correct tire pressure** (tread worn evenly)

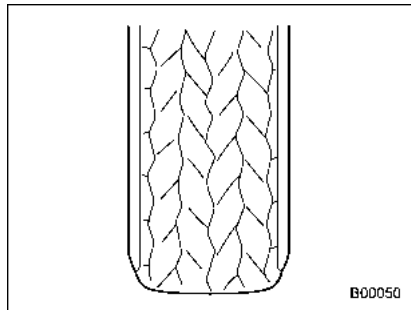

Roadholding is good, and steering is responsive. Rolling resistance is low, so fuel consumption is also lower.

- **Abnormally low tire pressure** (tread worn at shoulders)

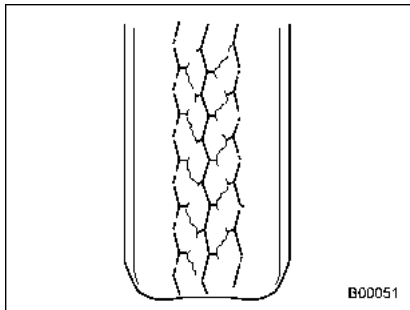

Rolling resistance is high, so fuel consumption is also higher.

- **Abnormally high tire pressure** (tread worn in center)

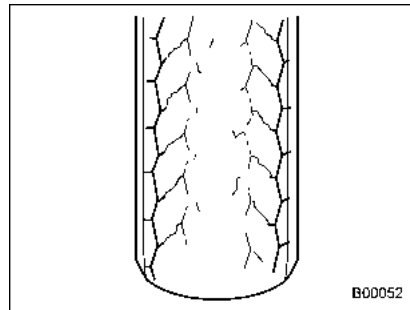

Ride comfort is poor. Also, the tire magnifies the effects of road-surface bumps and dips, possibly resulting in vehicle damage.

If the tire placard shows tire pressures for the vehicle when fully loaded, adjust the tire pressures to the values that match current loading conditions.



WARNING

Driving at high speeds with excessively low tire pressures can cause the tires to deform severely and to rapidly become hot. A sharp increase in temperature could cause tread separation, and destruction of

the tires. The resulting loss of vehicle control could lead to an accident.

■ Wheel balance

Each wheel was correctly balanced when your vehicle was new, but the wheels will become unbalanced as the tires become worn during use. Wheel imbalance causes the steering wheel to vibrate slightly at certain vehicle speeds and detracts from the vehicle's straight-line stability. It can also cause steering and suspension system problems and abnormal tire wear. If you suspect that the wheels are not correctly balanced, have them checked and adjusted by your SUBARU dealer. Also have them adjusted after tire repairs and after tire rotation.



CAUTION

Loss of correct wheel alignment causes the tires to wear on one side and reduces the vehicle's running stability. Contact your SUBARU dealer if you notice abnormal tire wear.

NOTE

The suspension system is designed to hold each wheel at a certain alignment (relative to the other wheels and to the road) for optimum straight-line stability and cornering performance.

■ Wear indicators

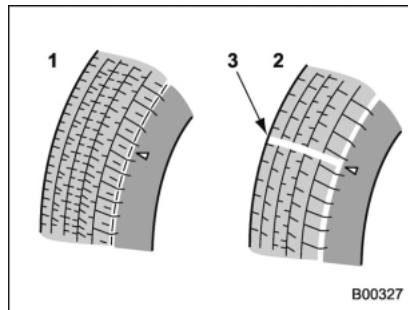

- 1) New tread
- 2) Worn tread
- 3) Tread wear indicator

Each tire incorporates a tread wear indicator, which becomes visible when the depth of the tread grooves decreases to 0.063 in (1.6 mm). A tire must be replaced when the tread wear indicator appears as a solid band across the tread.



WARNING

When a tire's tread wear indicator becomes visible, the tire is worn beyond the acceptable limit and must be replaced immediately. With a tire in this condition, driving at high speeds in wet weather can cause the vehicle to hydroplane. The resulting loss of vehicle control can lead to an accident.

NOTE

For safety, inspect tire tread regularly and replace the tires before their tread wear indicators become visible.

■ Tire rotation direction mark

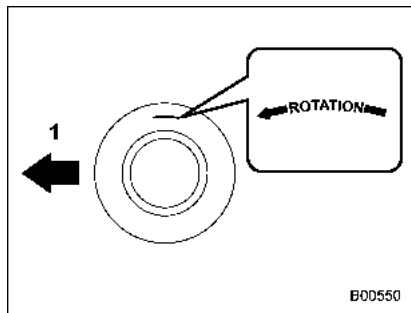

Example of tire rotation direction mark
1) Front

If the tire has the rotation direction specification, the tire rotation direction mark is placed on its sidewall.

When you install a tire that has the tire rotation direction mark, install the tire with the direction mark facing forward.

■ Tire rotation

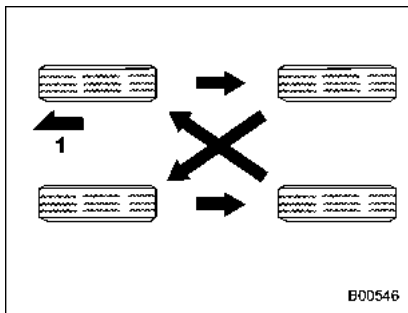

Vehicles equipped with 4 non-unidirectional tires
1) Front

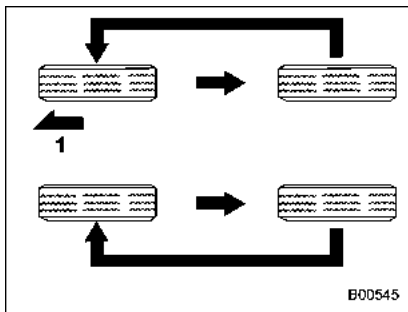

Vehicles equipped with unidirectional tires
1) Front

Tire wear varies from wheel to wheel. Move the tires to the positions shown in the illustration each time they are rotated. For the tire rotation schedule, refer to the "Warranty and Maintenance Booklet".

Replace any damaged or unevenly worn tires at the time of rotation. After tire rotation, adjust the tires pressures and make sure the wheel nuts are correctly tightened.

After driving approximately 600 miles (1,000 km), check the wheel nuts again and retighten any nut that has become loose.

■ Tire replacement

The wheels and tires are important and integral parts of your vehicle's design; they cannot be changed arbitrarily. The tires fitted as standard equipment are optimally matched to the characteristics of the vehicle and were selected to give the best possible combination of running performance, ride comfort, and service life. It is essential for every tire to have a size and construction matching those shown on the tire placard and to have a speed symbol and load index matching those shown on the tire placard.

Using tires of a non-specified size detracts

from controllability, ride comfort, braking performance, speedometer accuracy and odometer accuracy. It also creates incorrect body-to-tire clearances and inappropriately changes the vehicle's ground clearance.

All four tires must be the same in terms of manufacturer, brand (tread pattern), construction, and size. You are advised to replace the tires with new ones that are identical to those fitted as standard equipment.

For safe vehicle operation, SUBARU recommends replacing all four tires at the same time.

 **WARNING**

- **When replacing or installing tire(s), all four tires must be the same for the following items.**

- (a) Size
- (b) Circumference
- (c) Speed symbol
- (d) Load index
- (e) Construction
- (f) Manufacturer
- (g) Brand (tread pattern)
- (h) Degrees of wear

For items (a) to (d), you must obey the specification that is printed on the tire placard. The tire placard is located on the driver's door pillar.

If all four tires are not the same in items (a) to (h), there is a possibility that it may lead to serious mechanical damage to the drive train of your car and affect the following factors.

- Ride
- Handling
- Braking
- Speedometer/Odometer calibration
- Clearance between the body and the tires

It also may be dangerous and lead to loss of vehicle control, and it can lead to an accident.

- **Use only radial tires. Do not use radial tires together with belted bias tires and/or bias-ply tires. Doing so can dangerously reduce controllability, resulting in an accident.**

■ Wheel replacement

When replacing wheels due, for example, to damage, make sure the replacement wheels match the specifications of the wheels that are fitted as standard equipment. Replacement wheels are available from SUBARU dealers.

 **WARNING**

Use only those wheels that are specified for your vehicle. Wheels not meeting specifications could interfere with brake caliper operation and may cause the tires to rub against the wheel well housing during turns. The resulting loss of vehicle control could lead to an accident.

NOTE

When any of the wheels are removed and replaced for tire rotation or to change a flat tire, always check the tightness of the wheel nuts after driving approximately 600 miles (1,000 km). If any nut is loose, tighten it to the specified torque.

Aluminum wheels

Aluminum wheels can be scratched and damaged easily. Handle them carefully to maintain their appearance, performance, and safety.

- When any of the wheels are removed and replaced for tire rotation or to change a flat tire, always check the tightness of the wheel nuts after driving approximately 600 miles (1,000 km). If any nut is loose, tighten it to the specified torque.
- Never apply oil to the threaded parts, wheel nuts, or tapered surface of the wheel.
- Never let the wheel rub against sharp protrusions or curbs.
- When wheel nuts, balance weights, or the center cap is replaced, be sure to replace them with genuine SUBARU parts designed for aluminum wheels.

Windshield washer fluid

CAUTION

Never use engine coolant as washer fluid because it could cause paint damage.

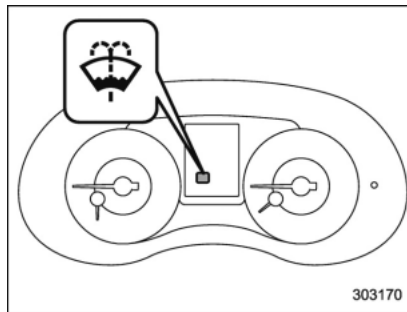

When there is only a small amount of washer fluid remaining, the windshield washer fluid warning indicator will illuminate. When this occurs, refill the washer fluid as follows.

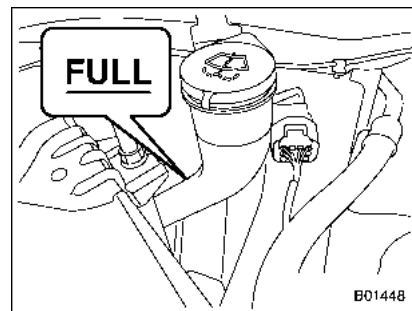

Remove the washer tank filler cap, then add windshield washer fluid until it reaches the "FULL" mark on the tank. If windshield washer fluid is unavailable use clean water.

In areas where water freezes in winter, use an anti-freeze type windshield washer fluid. SUBARU Windshield Washer Fluid contains 58.5% methyl alcohol and 41.5% surfactant, by volume. Its freezing temperature varies according to how much it is diluted, as indicated in the following table.

Washer Fluid Concentration	Freezing Temperature
30%	10.4° F (-12° C)
50%	-4° F (-20° C)
100%	-49° F (-45° C)

In order to prevent freezing of washer fluid, check the freezing temperatures in the table above when adjusting the fluid concentration to the outside temperature.

If you fill the reservoir tank with a fluid with a different concentration from the one used previously, purge the old fluid from the piping between the reservoir tank and washer nozzles by operating the washer for a certain period of time. Otherwise, if the concentration of the fluid remaining in the piping is too low for the outside temperature, it may freeze and block the nozzles.

**CAUTION**

- **Adjust the washer fluid concentration appropriately for the outside temperature. If the concentration is inappropriate, sprayed washer fluid may freeze on the windshield and obstruct your view, and the fluid may freeze in the reservoir tank.**
- **State or local regulations on volatile organic compounds may restrict the use of methanol, a common windshield washer anti-freeze additive. Washer fluids containing non-methanol anti-freeze agents should be used only if they provide cold weather protection without damaging your vehicle's paint, wiper blades or washer system.**

Replacement of wiper blades

Grease, wax, insects, or other material on the windshield or the wiper blade results in jerky wiper operation and streaking on the glass. If you cannot remove the streaks after operating the windshield washer or if the wiper operation is jerky, clean the outer surface of the windshield (or rear window) and the wiper blades using a sponge or soft cloth with a neutral detergent or mild-abrasive cleaner. After cleaning, rinse the windshield and wiper blades with clean water. The windshield is clean if beads do not form when you rinse the windshield with water.

**CAUTION**

- **Do not clean the wiper blades with gasoline or a solvent, such as paint thinner or benzene. This will cause deterioration of the wiper blades.**
- **While removing the wiper blades from the wiper arms, do not return the wiper arms to the original positions. Otherwise, the windshield surface may be scratched.**
- **When returning the raised wiper arms to the original positions,**

carefully return the wiper arms on the windshield by hand. You should not return the wiper arms to the windshield only by the return spring. Otherwise, the wiper arms may be deformed and/or the windshield surface may be scratched.

If you cannot eliminate the streaking even after following this method, replace the wiper blades using the following procedures.

■ Windshield wiper blade assembly

1. Raise the wiper arm off the windshield.

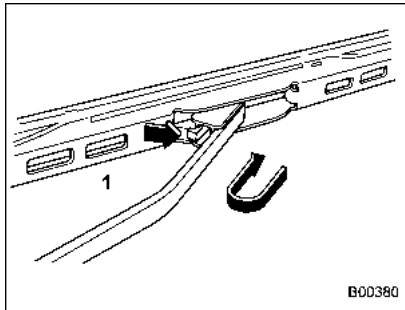

- 1) Stopper

2. Remove the wiper blade assembly by holding its pivot area and pushing it in the direction shown by the arrow while depressing the wiper blade stopper.
3. Install the wiper blade assembly to the wiper arm. Make sure that it locks in place.
4. Hold the wiper arm by hand and slowly lower it in position.

■ Windshield wiper blade rubber

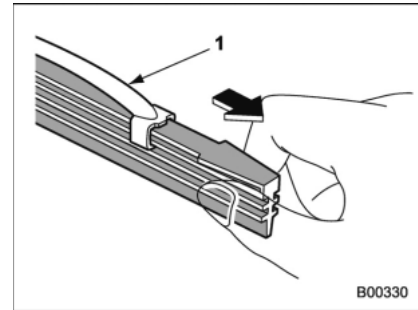

- 1) Metal support

1. Grasp the locked end of the blade rubber assembly and pull it firmly until the stoppers on the rubber are free of the metal support.

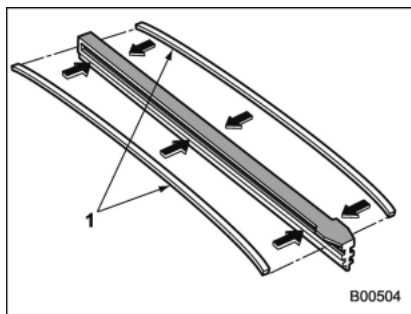

1) Metal spines

2. If the new blade rubber is not provided with two metal spines, remove the metal spines from the old blade rubber and install them in the new blade rubber.

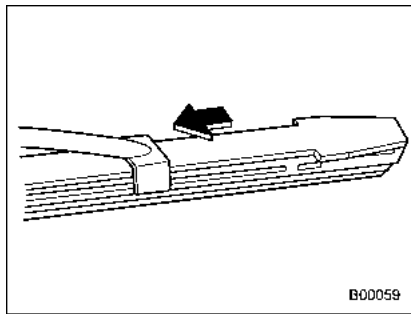

3. Align the claws of the metal support

with the grooves in the rubber and slide the blade rubber assembly into the metal support until it locks.

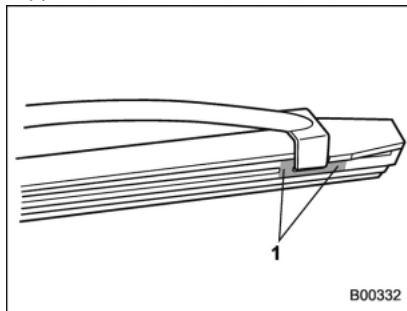

1) Stopper

4. Be sure to position the claws at the end of the metal support between the stoppers on the rubber as shown. If the rubber is not retained properly, the wiper blade may scratch the windshield.

Battery

WARNING

- Before beginning work on or near any battery, be sure to extinguish all cigarettes, matches, and lighters. Never expose a battery to an open flame or electric sparks. Batteries give off a gas which is highly flammable and explosive.
- For safety, in case an explosion does occur, wear eye protection or shield your eyes when working near any battery. Never lean over a battery.
- Do not let battery fluid contact eyes, skin, fabrics, or paint because battery fluid is a corrosive acid. If battery fluid gets on your skin or in your eyes, immediately flush the area with water thoroughly. Seek medical help immediately if acid has entered the eyes.

If battery fluid is accidentally swallowed, immediately drink a large amount of milk or water, and seek medical attention immediately.

- To lessen the risk of sparks,

remove rings, metal watchbands, and other metal jewelry. Never allow metal tools to contact the positive battery terminal and anything connected to it WHILE you are at the same time in contact with any other metallic portion of the vehicle because a short circuit will result.

- Keep everyone including children away from the battery.
- Charge the battery in a well-ventilated area.
- Battery posts, terminals and related accessories contain lead and lead compounds, chemicals known to the State of California to cause cancer and reproductive harm. Batteries also contain other chemicals known to the State of California to cause cancer. *Wash hands after handling.*

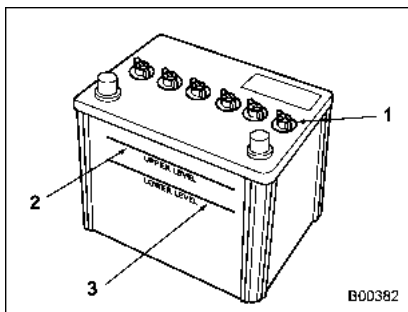

- 1) Cap
- 2) Upper level
- 3) Lower level

It is unnecessary to periodically check the battery fluid level or periodically refill with distilled water.

However, if the battery fluid level is below the lower level, remove the cap. Fill to the upper level with distilled water.

CAUTION

Never use more than 10 amperes when charging the battery because it will shorten battery life.

Fuses

CAUTION

Never replace a fuse with one having a higher rating or with material other than a fuse because serious damage or a fire could result.

The fuses are designed to melt during an overload to prevent damage to the wiring harness and electrical equipment. The fuses are located in two fuse boxes.

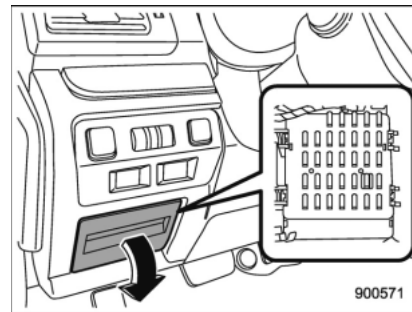

One is located under the instrument panel behind the fuse box cover on the driver's seat side. To remove the cover, pull it out.

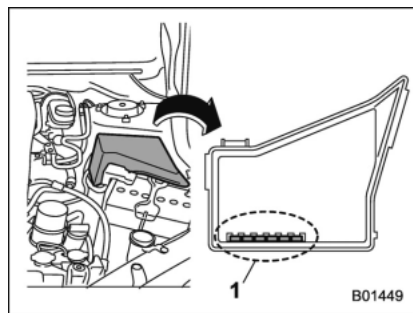

1) Spare fuses

The other one (main fuse box) is housed in the engine compartment. Also, the spare fuses are stored in the fuse box cover.

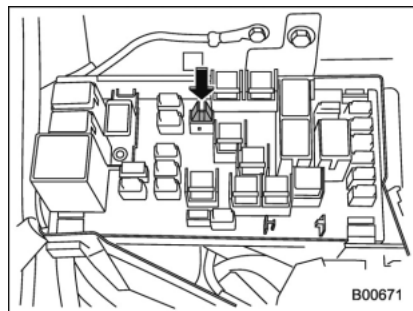

The fuse puller is stored in the main fuse

box in the engine compartment.

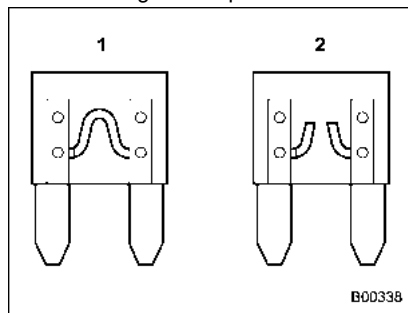

- 1) Good
- 2) Blown

If any lights, accessories or other electrical controls do not operate, inspect the corresponding fuse. If a fuse has blown, replace it.

1. Turn the ignition switch to the "LOCK"/"OFF" position and turn off all electrical accessories.
2. Remove the cover.
3. Determine which fuse may be blown. Look at the back side of each fuse box cover and refer to "Fuses and circuits" 12-9.

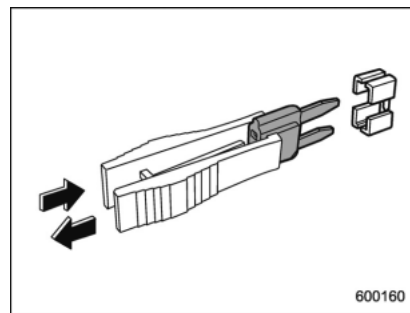

4. Pull out the fuse with the fuse puller.
5. Inspect the fuse. If it has blown, replace it with a spare fuse of the same rating.
6. If the same fuse blows again, this indicates that its system has a problem. Contact your SUBARU dealer for repairs.

Installation of accessories

Always consult your SUBARU dealer before installing fog lights or any other electrical equipment in your vehicle. Such accessories may cause the electronic system to malfunction if they are incorrectly installed or if they are not suited for the vehicle.

Replacing bulbs

WARNING

Bulbs may become very hot while illuminated. Before replacing bulbs, turn off the lights and wait until the bulbs cool down. Otherwise, there is a risk of sustaining a burn injury.

CAUTION

- Replace any bulb only with a new bulb of the specified wattage. Using a bulb of different wattage could result in a fire. For the specified wattage of each bulb, refer to “Bulb chart” 12-15.
- Do not touch the glass portion of the light bulb with bare hands. When holding the glass portion is unavoidable, hold it using with a clean dry cloth to avoid getting moisture and grease on the bulb. If there is any fingerprints or grease on the bulb surface, wipe them away with a soft cloth moistened with alcohol. Also, if the bulb is scratched or dropped, it may blow out or crack.

■ Headlights (models with LED headlights)

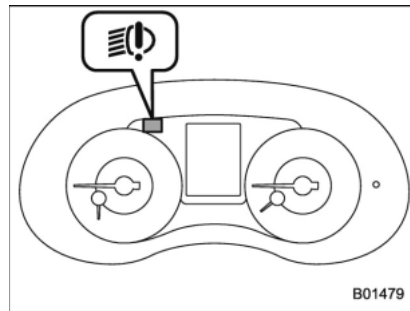

The LED headlight warning light illuminates if the LED headlights malfunction. Have your vehicle inspected at a SUBARU dealer as soon as possible.

■ High beam headlight

NOTE

- If headlight aiming is required, consult your SUBARU dealer for proper adjustment of the headlight aim.
- It may be difficult to replace the bulbs. Have the bulbs replaced by your SUBARU dealer if necessary.

Perform the following steps to replace the bulbs.

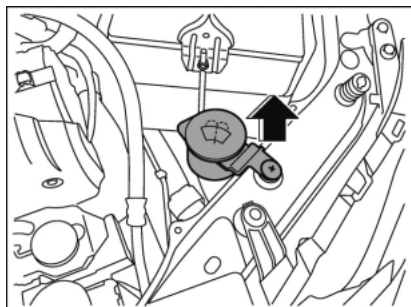

Left-hand side

1. **Left-hand side:** Use a screwdriver to remove the secured clip of the washer tank. To make it easy to access the bulb, turn the neck of the washer fluid filler pipe as illustrated.

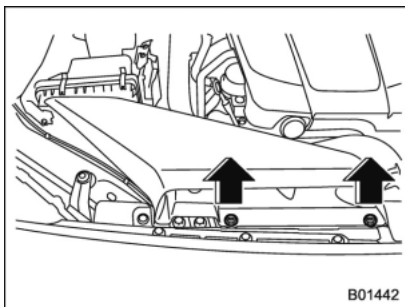

Right-hand side

Right-hand side: Use a screwdriver to undo the clips on the air intake duct, then remove the air intake duct.

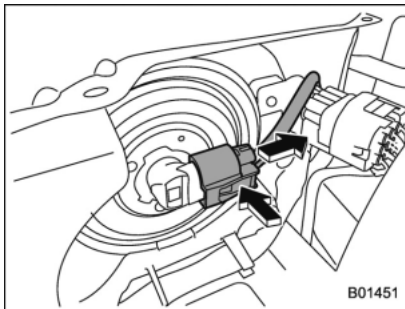

2. Disconnect the electrical connector from the bulb as pushing the tab.

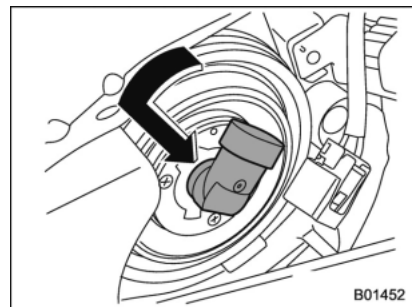

Left-hand side

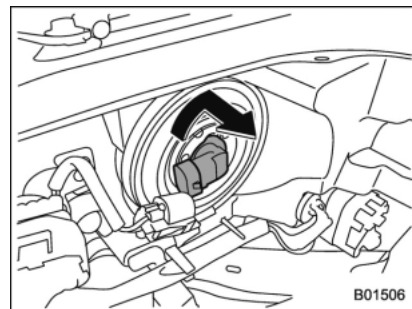

Right-hand side

3. **Left-hand side:** Remove the bulb from the headlight assembly by turning it counterclockwise.

Right-hand side: Remove the bulb from

the headlight assembly by turning it clockwise.

4. Replace the bulb with new one. At this time, use care not to touch the bulb surface.

5. To install the bulb to the headlight assembly, turn it to the reverse direction until it clicks.

6. Reconnect the electrical connector.

7. **Left-hand side:** Set the washer fluid filler pipe to the original place and secure it by clip.

Right-hand side: Install the air intake duct with clips.

■ **Low beam headlight (models without LED headlights), front side marker light (if equipped), parking light (models without LED headlights) and front turn signal light**

NOTE

- If headlight aiming is required, consult your SUBARU dealer for proper adjustment of the headlight aim.
- It may be difficult to replace the bulbs. Have the bulbs replaced by your SUBARU dealer if necessary.

1. Start the engine and turn the steering

wheel fully in the opposite direction of the bulb to be replaced.

2. Stop the engine.

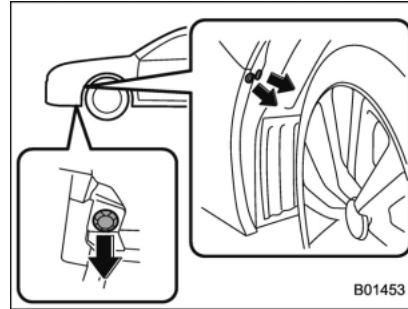

3. Remove the clips from the mud guard.

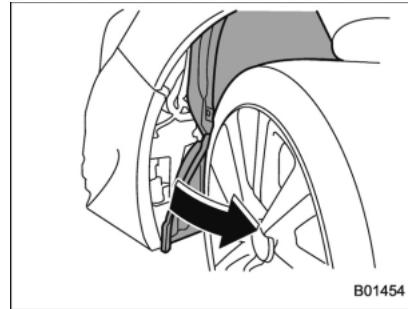

4. Pull off the mud guard.

▼ **Low beam headlight**

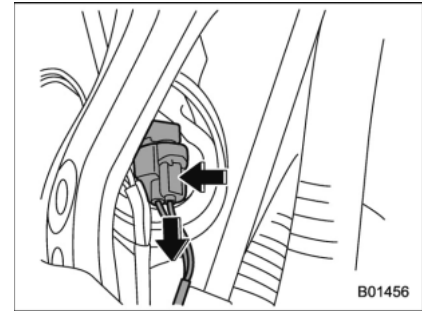
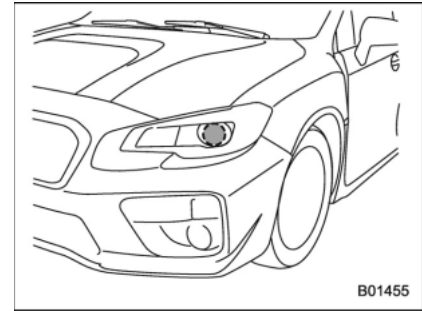

1. Disconnect the electrical connector from the bulb as pushing the tab.

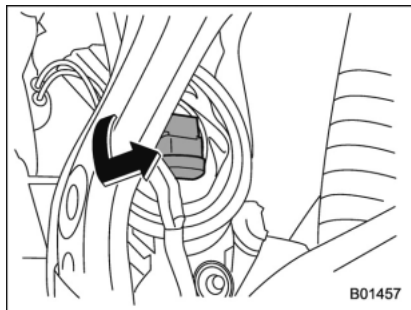

2. Remove the bulb from the headlight assembly by turning it counterclockwise.
3. Replace the bulb with a new one. At this time, use care not to touch the bulb surface.
4. To install the bulb to the headlight assembly, turn it clockwise until it clicks.
5. Reconnect the electrical connector.
6. Reattach the mud guard.

▼ Front side marker light, parking light and front turn signal light

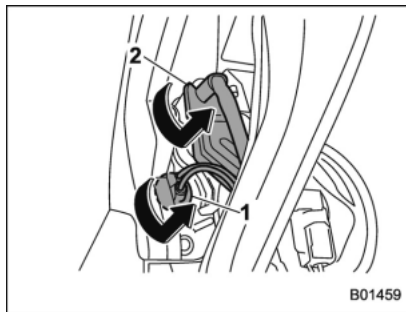
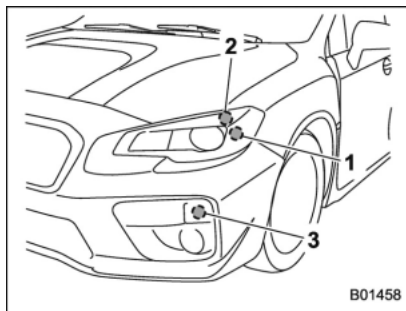

- 1) Front side marker light
- 2) Parking light

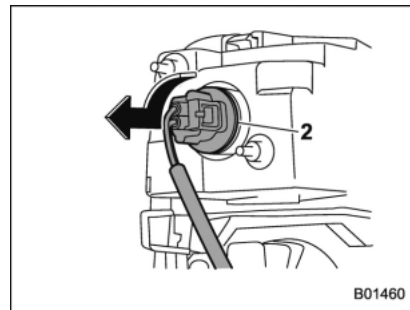

3) Front turn signal light

1. Turn the socket counterclockwise and pull it out.
2. Pull out the bulb from the socket and replace the bulb with a new one.
3. After replacing the bulb, reattach the mud guard.

■ Front fog light (if equipped)

NOTE

It may be difficult to replace the bulbs. Have the bulbs replaced by your SUBARU dealer if necessary.

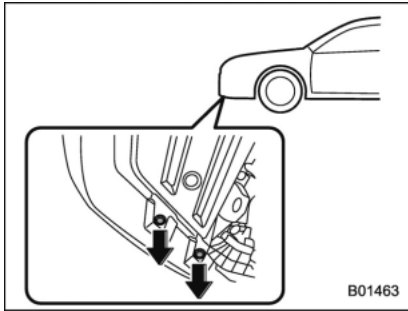

1. Remove the clips.

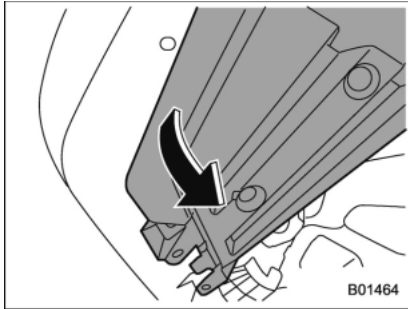

2. Turn over the mud guard.

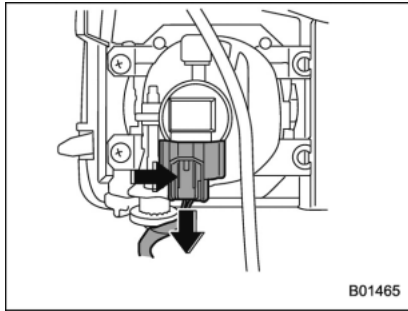

3. Disconnect the electrical connector from the bulb as pushing the tab.

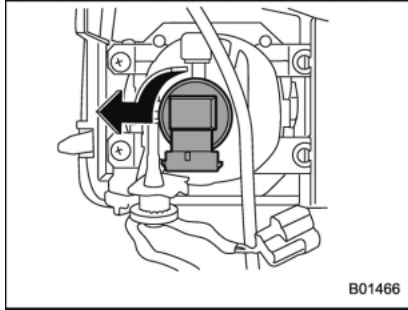

4. Remove the bulb by turning it counter-clockwise.
 5. Replace the bulb with a new one.
 6. After replacing the bulb, reattach the

mud guard.

■ Rear combination lights

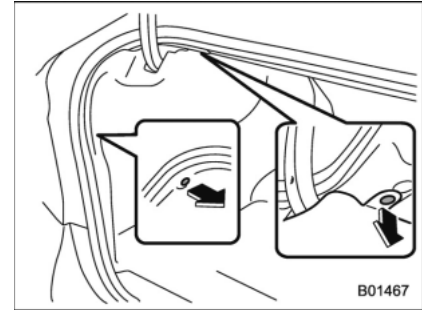

1. Remove the clips from the trunk trim with a flat-head screwdriver.

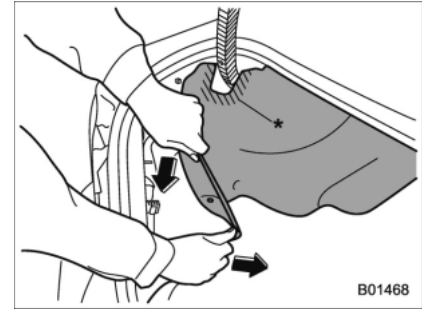

2. Open the rear portion of the trunk trim panel as illustrated.

NOTE

Make sure that the “*” part of the trunk trim in the illustration does not contact the trunk lid stay. If the “*” part is bent, the trunk trim may be torn.

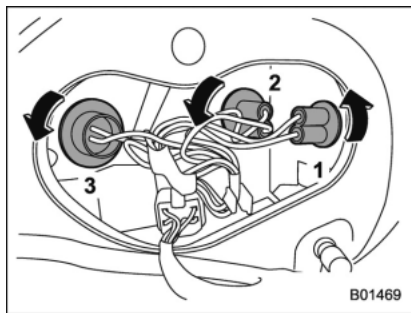

- 1) Rear side marker light
- 2) Backup light
- 3) Rear turn signal light

3. Remove the bulb socket from the rear combination light assembly by turning it counterclockwise.
4. Pull the bulb out of the bulb socket and replace it with a new one.
5. Set the bulb socket into the rear combination light assembly and turn it

clockwise until it locks.

6. Secure the rear trunk trim panel with the clips.

NOTE

When replacing a bulb of the rear side marker light, detach the bulb socket of the backup light in advance. After replacing the bulb, first attach the side marker light, and then attach the back-up light.

■ License plate light

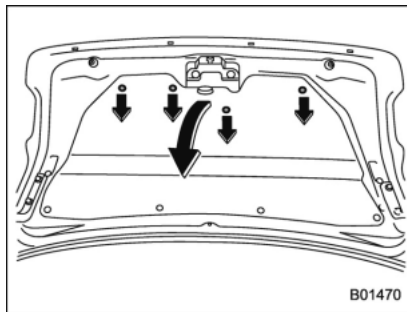

1. Open the trunk and remove the clips from the trunk lid trim with a flat-head screwdriver.
2. Turn over the trunk lid trim.

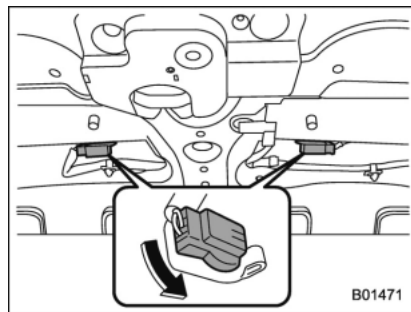

3. Turn the bulb socket counterclockwise and pull out the socket.
4. Pull the bulb out of the socket.
5. Install a new bulb.
6. Reinstall the bulb socket and the trunk lid trim.

■ Other bulbs

It may be difficult to replace the bulbs. Have the bulbs replaced by your SUBARU dealer if necessary.

Battery replacement

The access key / transmitter battery may be discharged under the following conditions.

- The operation of the keyless access function is unstable
- The operating distance of the remote keyless entry system is unstable
- The transmitter does not operate properly when used within the standard distance

Replace the battery with a new one.



CAUTION

- Do not let dust, oil or water get on or in the access key/transmitter when replacing battery.
- Be careful not to damage the printed circuit board in the access key/transmitter when replacing the battery.
- Be careful not to allow children to touch the battery and any removed parts; children could swallow them.
- There is a danger of an explosion if the battery is incorrectly replaced. Replace only with the

same or equivalent type of the battery.

- Do not expose batteries to excessive heat such as bright sunlight, fire or the like.

NOTE

- Replace only with the same or equivalent type of battery recommended by the manufacturer.
- Dispose of used batteries according to local laws.
- Mount the battery in the correct orientation to prevent fluid leakage. Be careful not to bend the terminals. It may result in a malfunction.
- It is recommended that the battery should be replaced by a SUBARU dealer.
- Use a new battery.
- After replacing the battery, confirm that the access key/transmitter functions properly.

■ Replacing access key battery

Battery: Button battery CR1632

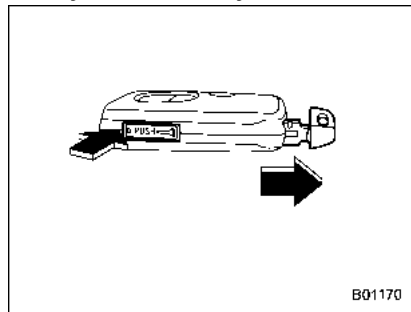

B01170

1. Pull out the mechanical key.

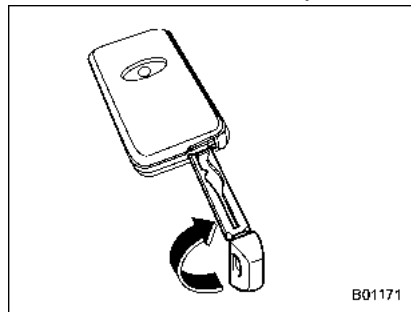

B01171

2. Insert the key into the gap and turn it clockwise to remove the cover.

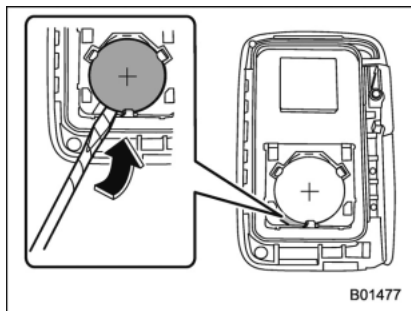

3. Wrap a flat-head screwdriver with insulating tape, and insert it between the battery and the board. Then pry it out from the board.

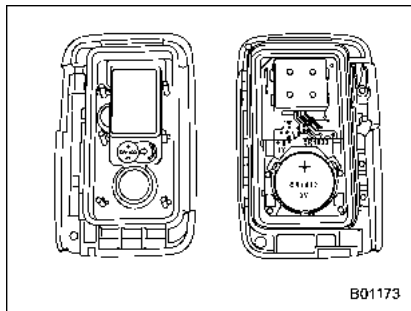

4. Insert a new battery with its positive (+) side facing upward as shown in the

illustration. Attach the cover firmly.

■ Replacing transmitter battery

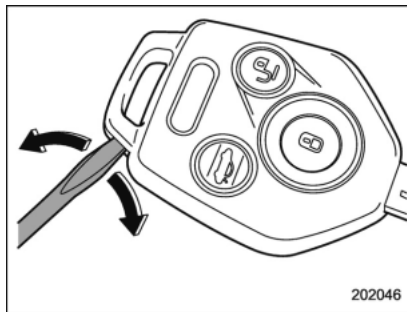

1. Open the key head using a flat-head screwdriver.

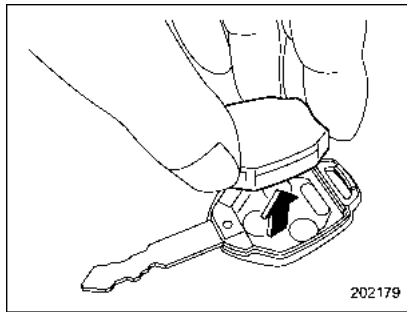

2. Remove the transmitter case from the key head.

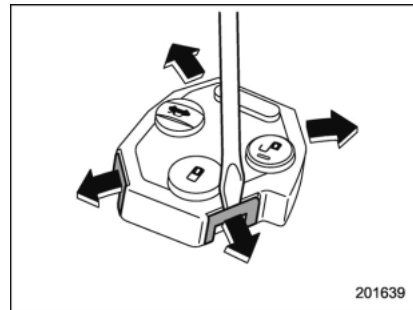

3. Open the transmitter case by releasing the hooks.

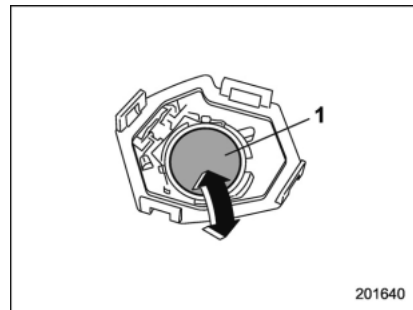

1) Negative (-) side facing up

4. Replace the old battery with a new battery (type **CR1620** or equivalent) making sure to install the new battery with the negative (-) side facing up.
5. Put together the transmitter case by fitting the hooks on the case.
6. Reinstall the transmitter case in the key head.
7. Refit the removed half of the key head.

After the battery is replaced, the transmitter must be synchronized with the remote keyless entry system's control unit. Press either the "⏏" or "⏏" button six times to synchronize the unit.

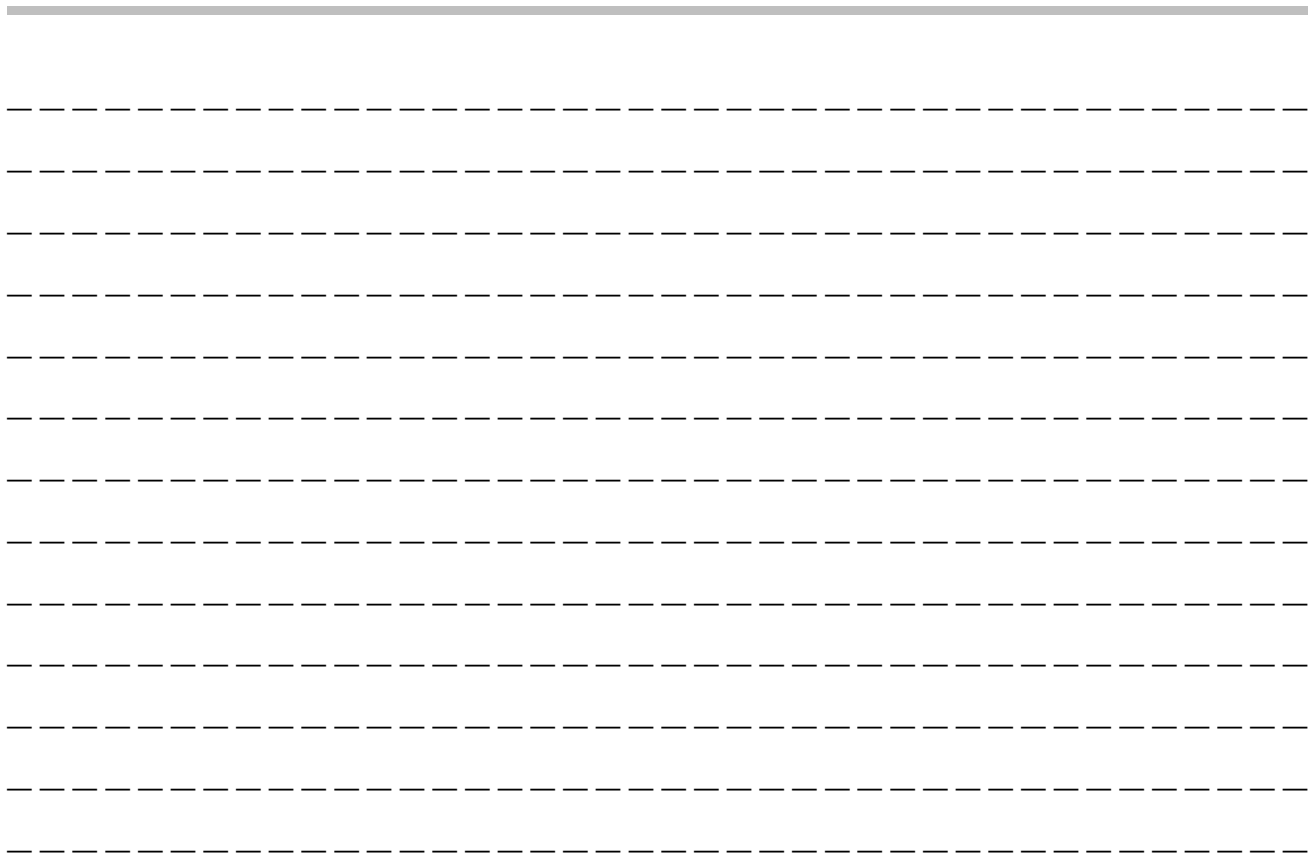

Specifications	12-2	Tires	12-8
Dimensions	12-2	Temporary spare tires	12-8
Engine	12-3	Fuses and circuits	12-9
Fuel	12-3	Fuse panel located in the passenger compartment	12-9
Engine oil	12-4	Fuse panel located in the engine compartment	12-11
Manual transmission, front differential and rear differential gear oil	12-6	Bulb chart	12-15
Fluids	12-7	Vehicle identification	12-17
Engine coolant	12-7		
Electrical system	12-8		

Specifications

These specifications are subject to change without notice.

■ Dimensions

Item		STI	Except STI	in (mm)
Overall length			180.9 (4,595)	
Overall width			70.7 (1,795)	
Overall height			58.0 (1,475)	
Wheel base			104.3 (2,650)	
Tread	Front		60.2 (1,530)	
	Rear		60.6 (1,540)	
Ground clearance			4.9 (125)	

■ Engine

Model	STI	Except STI
Engine model	EJ257 (2.5 L, DOHC, turbo)	FA20 (2.0 L, DOHC, turbo)
Engine type	Horizontally opposed, liquid cooled 4 cylinder, 4-stroke petrol engine	
Displacement cu-in (cc)	150 (2,457)	121.9 (1,998)
Bore × Stroke in (mm)	3.9 × 3.1 (99.5 × 79.0)	3.39 × 3.39 (86.0 × 86.0)
Compression ratio	8.2 : 1	10.6 : 1
Firing order	1 – 3 – 2 – 4	

■ Fuel

NOTE

The engine is designed to operate using unleaded gasoline.

Model	Fuel	Fuel tank capacity
STI	93 AKI (98 RON) or higher* ¹	15.9 US gal (60 liters, 13.2 Imp gal)
Except STI	91 AKI (95 RON) or higher* ²	

*1: If unleaded gasoline with an octane rating of 93 AKI (98 RON) is not available, unleaded gasoline with an octane rating of 91 AKI (95 RON) may be used with no detriment to engine durability or driveability.

*2: If unleaded gasoline with an octane rating of 91 AKI (95 RON) is not available, unleaded gasoline with an octane rating of 87 AKI (90 RON) or higher may be temporarily used.

■ Engine oil

For the checking, adding and replacing procedure or other details, refer to "Engine oil" 11-12.

NOTE

The procedure for changing the engine oil and oil filter should be performed by a properly-trained expert. It is recommended that you have this service performed by your SUBARU dealer.

▼ Oil filter

Model	STI	Except STI
Oil filter color	Black	Black
Part number	15208AA100	15208AA170
Amount of rotation	1 rotation	1 rotation

▼ Approved engine oil



We recommend that you always use the SUBARU approved engine oil. For further details, please contact your SUBARU dealer. If the approved engine oil is unavailable, use the alternative engine oil described on the next page.

▼ Alternative engine oil

If the SUBARU approved oil is unavailable, the following alternative oil can be used.

NOTE

Each quantity indicated here is only a guideline. The necessary quantity for replacement may differ slightly depending on the temperature and other factors.

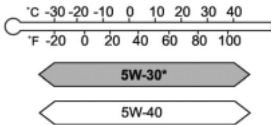
Oil grade	SAE viscosity No. and applicable temperature	Engine oil capacity
<div style="display: flex; justify-content: space-around; align-items: center;"> <div style="text-align: center;">  <p>ZOM0377</p> <p>API (American Petroleum Institute) classification SM with the words "ENERGY CONSERVING" or SN with the words "RESOURCE CONSERVING"</p> </div> <div style="text-align: center;"> <p>or</p>  <p>ZOM0293</p> <p>ILSAC (International Lubricant Specification Advisory Committee) GF-4 or GF-5, which can be identified with the ILSAC certification mark (Starburst mark)</p> </div> </div>	<p>5W-30 synthetic oil is the required oil for optimum engine performance and protection. Conventional oil may be used if synthetic oil is unavailable.</p> <p>*: If 5W-30 synthetic oil is not available, 5W-40 conventional oil may be used if replenishment is needed but should be changed to 5W-30 synthetic oil at the next oil change.</p> <div style="text-align: center;">  <p>ZOM0334</p> </div>	<p>STI:</p> <ul style="list-style-type: none"> · Adding the oil from L to F level: 1.1 US qt (1.0 liter, 0.9 Imp qt) · Changing the oil and oil filter: 4.5 US qt (4.3 liters, 3.8 Imp qt) · Changing the oil: 4.2 US qt (4.0 liters, 3.5 Imp qt) <p>Except STI:</p> <ul style="list-style-type: none"> · Adding the oil from L to F level: 1.1 US qt (1.0 liter, 0.9 Imp qt) · Changing the oil and oil filter: 5.4 US qt (5.1 liters, 4.5 Imp qt) · Changing the oil: 5.2 US qt (4.9 liters, 4.3 Imp qt)

Manual transmission, front differential and rear differential gear oil

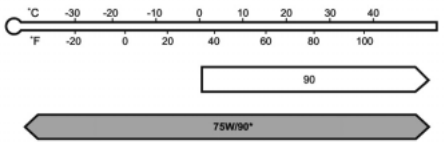
Oil		Manual transmission oil	Front differential gear oil (CVT models)	Rear differential gear oil
Oil grade	STI	<ul style="list-style-type: none"> API classification GL-5 (75W-90)*³ 	<ul style="list-style-type: none"> SUBARU Extra MT*³ API classification GL-5 (75W-90) 	API classification GL-5
	Except STI	<ul style="list-style-type: none"> SUBARU Extra MT*³ API classification GL-5 (75W-90)*⁴ 		
SAE viscosity No. and applicable temperature		—	—	<ul style="list-style-type: none"> 75W-90* 90  <p style="text-align: right;">ZOM0394</p>
Oil capacity* ¹	STI	4.3 US qt (4.1 liters, 3.6 Imp qt)	—	1.1 US qt (1.0 liter, 0.9 Imp qt)
	Except STI	3.5 US qt (3.3 liters, 2.9 Imp qt)	1.5 US qt (1.4 liters, 1.2 Imp qt)	0.8 US qt (0.8 liters, 0.7 Imp qt)
Remarks* ²		"Manual transmission oil" ☞ 11-22	"Front differential gear oil (CVT models)" ☞ 11-22	"Rear differential gear oil" ☞ 11-23

*1: The indicated oil quantity is only a guideline. The necessary quantity for replacement may differ slightly depending on the temperature and other factors. After refilling the gearbox with oil, the oil level should be checked.

*2: For more details about maintenance and service, refer to the indicated section.

*3: The vehicle is filled at the factory with this oil.

*4: You may use this type of manual transmission oil. However, using this type of oil will detract from driveability and fuel efficiency.

■ Fluids

Fluid	Fluid type*1	Fluid capacity*2	Remarks*3
Continuously variable transmission fluid (CVT models)	Consult your SUBARU dealer.	13.1 US qt (12.4 liters, 10.9 Imp qt)	"Continuously variable transmission fluid" ☞11-22
Brake fluid	FMVSS No. 116, fresh DOT 3 or DOT 4 brake fluid	–	"Brake fluid" ☞11-24
Clutch fluid (MT models)	FMVSS No. 116, fresh DOT 3 or DOT 4 brake fluid	–	"Clutch fluid (MT models)" ☞11-25
Power steering fluid (STI)	<ul style="list-style-type: none"> · SUBARU ATF · "Dexron III" Type Automatic Transmission Fluid · IDEMITSU ATF HP 	0.7 US qt (0.7 liter, 0.6 Imp qt)	"Power steering fluid (STI)" ☞11-23

*1: Use one of the indicated types of fluid.

*2: The indicated fluid quantity is only a guideline. The necessary quantity for replacement may differ slightly depending on the temperature and other factors.

*3: For more details about maintenance and service, refer to the indicated section.

■ Engine coolant

Vehicle model		Coolant capacity	Coolant type
STI		8.2 US qt (7.7 liters, 6.8 Imp qt)	SUBARU Super Coolant
Except STI	MT models	8.7 US qt (8.2 liters, 7.2 Imp qt)	
	CVT models	8.9 US qt (8.4 liters, 7.4 Imp qt)	

The indicated coolant quantity is only a guideline. The necessary quantity for replacement may differ slightly depending on the temperature and other factors. For more details about maintenance and service, refer to "Cooling system" ☞11-16.

■ Electrical system

Battery type and capacity (5HR)		55D23L (12V-48AH)
Alternator	STI	12V-110A
	Except STI	12V-130A
Spark plugs	STI	SILFR6A (NGK)
	Except STI	ILKAR8H6 (NGK)

■ Tires

Tire size		235/45R17 94W	245/40R18 97W
Wheel size		17 × 8J	18 × 8 1/2J
Pressure	Front	33 psi (230 kPa, 2.3 kgf/cm ²)	33 psi (230 kPa, 2.3 kgf/cm ²)
	Rear	32 psi (220 kPa, 2.2 kgf/cm ²)	32 psi (220 kPa, 2.2 kgf/cm ²)
Wheel nut tightening torque		89 lbf-ft (120 N·m, 12 kgf·m) ^{*1}	

*1: This torque is equivalent to applying approximately 88 to 110 lbf (40 to 50 kgf) at the end of the wheel nut wrench. If you have tightened the wheel nuts by yourself, have the tightening torque checked at the nearest automotive service facility as soon as possible. For the wheel nut tightening procedure, refer to "Changing a flat tire" 9-4.

■ Temporary spare tires

Temporary spare tire size	T145/70D17	205/50R17
Temporary spare tire inflation pressure (recommended cold tire inflation pressure)	60 psi (420 kPa, 4.2 kgf/cm ²)	33 psi (230 kPa, 2.3 kgf/cm ²)
Wheel nut tightening torque	89 lbf-ft (120 N·m, 12 kgf·m) ^{*1 *2}	

*1: This torque is equivalent to applying approximately 88 to 110 lbf (40 to 50 kgf) at the end of the wheel nut wrench. If you have tightened the wheel nuts by yourself, have the tightening torque checked at the nearest automotive service facility as soon as possible.

*2: For the wheel nut tightening procedure, refer to "Changing a flat tire" 9-4.

Fuses and circuits

■ Fuse panel located in the passenger compartment

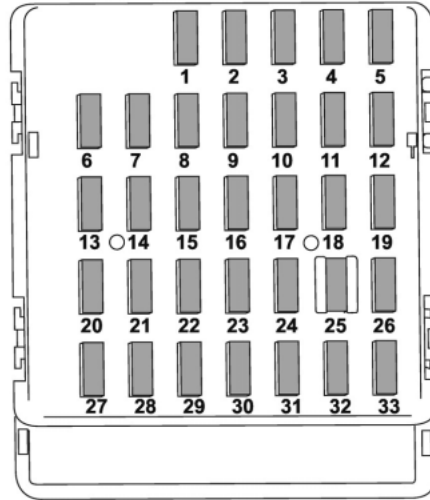

Fuse panel	Fuse rating	Circuit
1	20A	(Not available)
2	7.5A	● Combination meter
3	15A	● Door locking
4	10A	● Front wiper deicer relay
5	Empty	
6	7.5A	● Remote control rear view mirrors ● Seat heater relay
7	10A	● Combination meter ● Integrated unit
8	7.5A	● Stop light
9	7.5A	● Front wiper deicer
10	7.5A	● Power supply (battery)
11	7.5A	● Turn signal unit
12	15A	● Transmission control unit ● Engine control unit ● Integrated unit
13	20A	● Accessory power outlet (center console)
14	10A	● Parking light ● Tail light ● Rear combination light

C00123

12-10 Specifications/Fuses and circuits

Fuse panel	Fuse rating	Circuit
15	10A	<ul style="list-style-type: none">● Trunk light● Keyless unit
16	7.5A	<ul style="list-style-type: none">● Illumination
17	15A	<ul style="list-style-type: none">● Seat heaters
18	10A	<ul style="list-style-type: none">● Backup light
19	–	<ul style="list-style-type: none">● Daytime running lights
20	10A	<ul style="list-style-type: none">● Accessory power outlet (instrument panel)
21	7.5A	<ul style="list-style-type: none">● Starter relay
22	10A	<ul style="list-style-type: none">● Air conditioner● Rear window defogger relay coil
23	Empty	
24	10A	<ul style="list-style-type: none">● Audio unit● Navigation system (if equipped)
25	15A	<ul style="list-style-type: none">● SRS airbag system
26	7.5A	<ul style="list-style-type: none">● Power window relay● Radiator main fan relay
27	15A	<ul style="list-style-type: none">● Blower fan
28	15A	<ul style="list-style-type: none">● Blower fan
29	10A	<ul style="list-style-type: none">● Fog light
30	Empty	

Fuse panel	Fuse rating	Circuit
31	7.5A	<ul style="list-style-type: none">● Auto air conditioner unit● Integrated unit
32	7.5A	<ul style="list-style-type: none">● Clutch switch● Steering lock control unit
33	7.5A	<ul style="list-style-type: none">● Vehicle Dynamics Control unit

■ Fuse panel located in the engine compartment

▼ STI

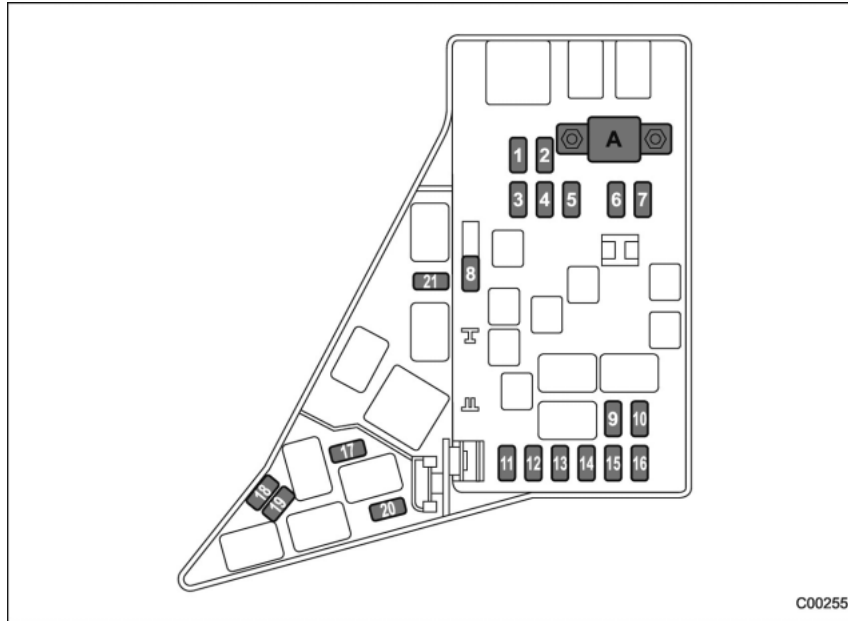

C00255

A) Main fuse

Fuse panel	Fuse rating	Circuit
1	30A	<ul style="list-style-type: none"> • ABS unit • Vehicle Dynamics Control unit
2	25A	<ul style="list-style-type: none"> • Main fan (cooling fan)
3	25A	<ul style="list-style-type: none"> • Sub fan (cooling fan)
4	Empty	
5	25A	<ul style="list-style-type: none"> • Audio
6	30A	<ul style="list-style-type: none"> • Headlight (low beam)
7	15A	<ul style="list-style-type: none"> • Headlight (high beam)
8	20A	<ul style="list-style-type: none"> • Back-up
9	15A	<ul style="list-style-type: none"> • Horn
10	25A	<ul style="list-style-type: none"> • Rear window defogger • Mirror heater
11	15A	<ul style="list-style-type: none"> • Fuel pump
12	10A	<ul style="list-style-type: none"> • Transmission control unit
13	7.5A	<ul style="list-style-type: none"> • Engine control unit
14	15A	<ul style="list-style-type: none"> • Turn and hazard warning flasher
15	15A	<ul style="list-style-type: none"> • Tail and illumination relay
16	7.5A	<ul style="list-style-type: none"> • Alternator

12-12 Specifications/Fuses and circuits

Fuse panel	Fuse rating	Circuit
17	Empty	
18	20A	● Injection
19	15A	● Headlight (low beam – right hand)
20	15A	● Headlight (low beam – left hand)
21	10A	● Secondary air combination valve

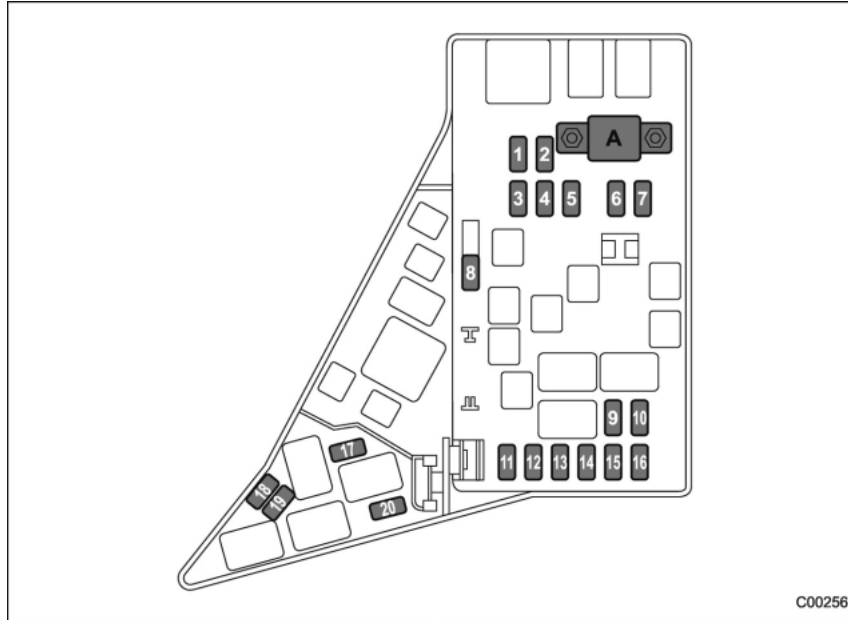
▼ **Except STI**

A) Main fuse

Fuse panel	Fuse rating	Circuit
1	30A	<ul style="list-style-type: none"> • ABS unit • Vehicle Dynamics Control unit
2	25A	<ul style="list-style-type: none"> • Main fan (cooling fan)
3	25A	<ul style="list-style-type: none"> • Sub fan (cooling fan)
4	Empty	
5	25A	<ul style="list-style-type: none"> • Audio
6	30A	<ul style="list-style-type: none"> • Headlight (low beam)
7	15A	<ul style="list-style-type: none"> • Headlight (high beam)
8	20A	<ul style="list-style-type: none"> • Back-up
9	15A	<ul style="list-style-type: none"> • Horn
10	25A	<ul style="list-style-type: none"> • Rear window defogger • Mirror heater
11	15A	<ul style="list-style-type: none"> • Fuel pump
12	20A	<ul style="list-style-type: none"> • Transmission control unit
13	7.5A	<ul style="list-style-type: none"> • Engine control unit
14	15A	<ul style="list-style-type: none"> • Turn and hazard warning flasher
15	15A	<ul style="list-style-type: none"> • Tail and illumination relay
16	7.5A	<ul style="list-style-type: none"> • Alternator

12-14 Specifications/Fuses and circuits

Fuse panel	Fuse rating	Circuit
17	Empty	
18	20A	● Injection
19	15A	● Headlight (low beam – right hand)
20	15A	● Headlight (low beam – left hand)

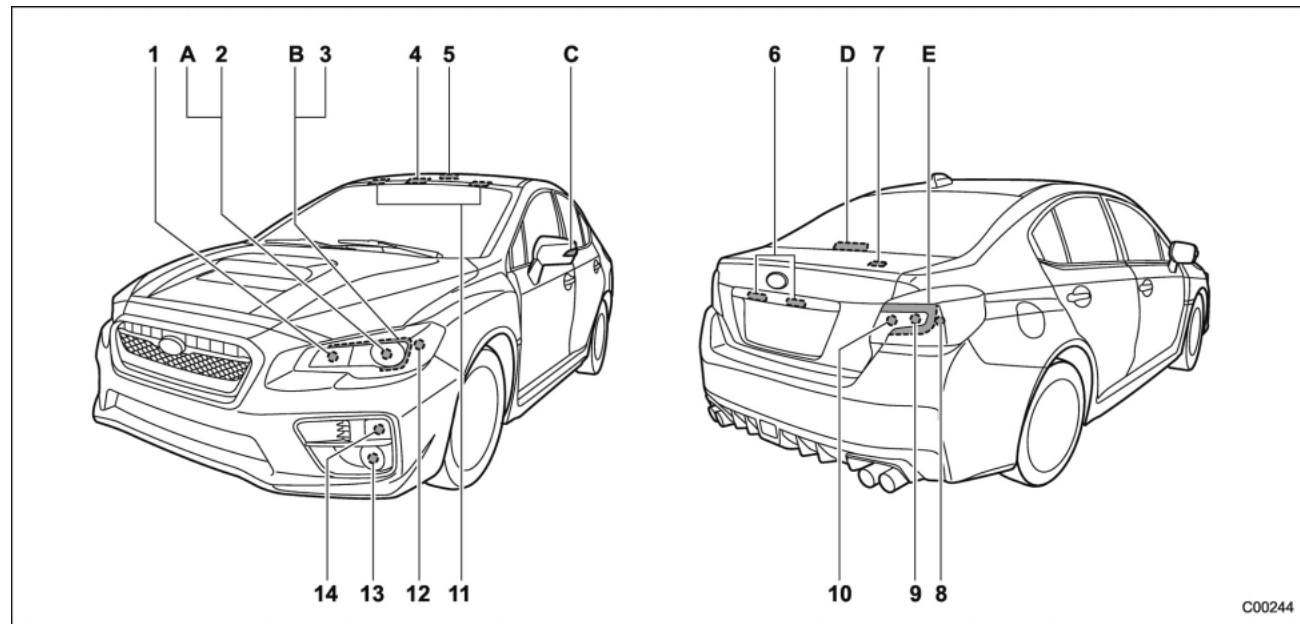
Bulb chart**NOTE**

Lights A, B and C are the LED (Light Emitting Diode) type. Consult your SUBARU dealer for replacement.

	Wattage	Bulb No.
1) High beam headlight	12V-60W	HB3
2) Low beam headlight (models without LED headlights)	12V-55W	H11
3) Parking light (models without LED headlights)	12V-5W	W5W
4) Map light	12V-8W	–
5) Dome light	12V-8W	–
6) License plate light	12V-5W	W5W
7) Trunk light	12V-5W	W5W
8) Rear side marker light	12V-5W	W5W
9) Backup light	12V-16W	W16W
10) Rear turn signal light	12V-21W	WY21W
11) Vanity mirror light	12V-2W	–
12) Front side marker light (if equipped)	12V-5W	W5W (168)
13) Front fog light	12V-19W	H16
14) Front turn signal light	12V-21W	WY21W
A) Low beam headlight (models with LED headlights)	–	–
B) Parking light (models with LED headlights)	–	–
C) Side turn signal light (if equipped)	–	–
D) High-mounted stop light	–	–
E) Stop light/Tail light	–	–



WARNING

Bulbs may become very hot while illuminated. Before replacing bulbs, turn off the lights and wait until the bulbs cool down. Otherwise, there is a risk of sustaining a burn injury.

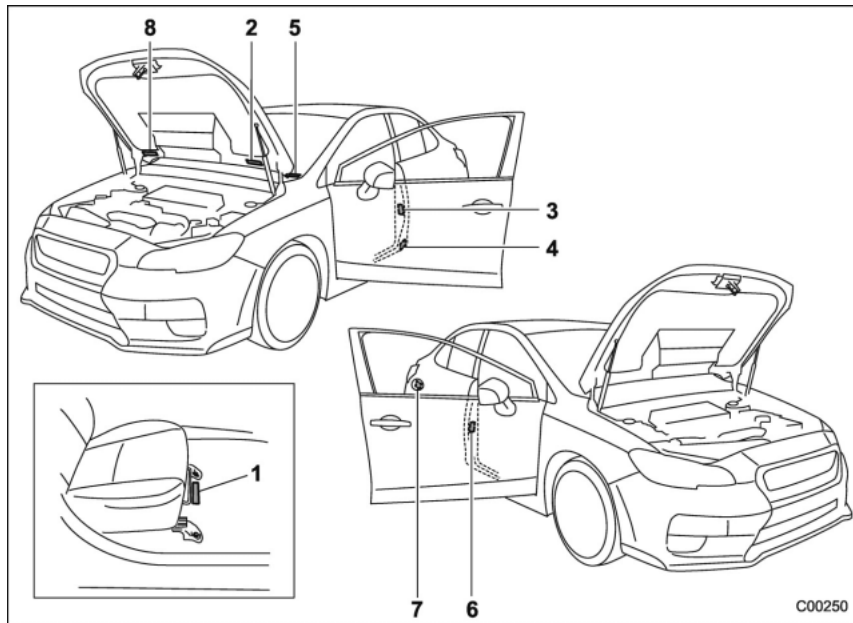

CAUTION

Replace any bulb only with a new bulb of the specified wattage. Using a bulb of different wattage could result in a fire.

Vehicle identification

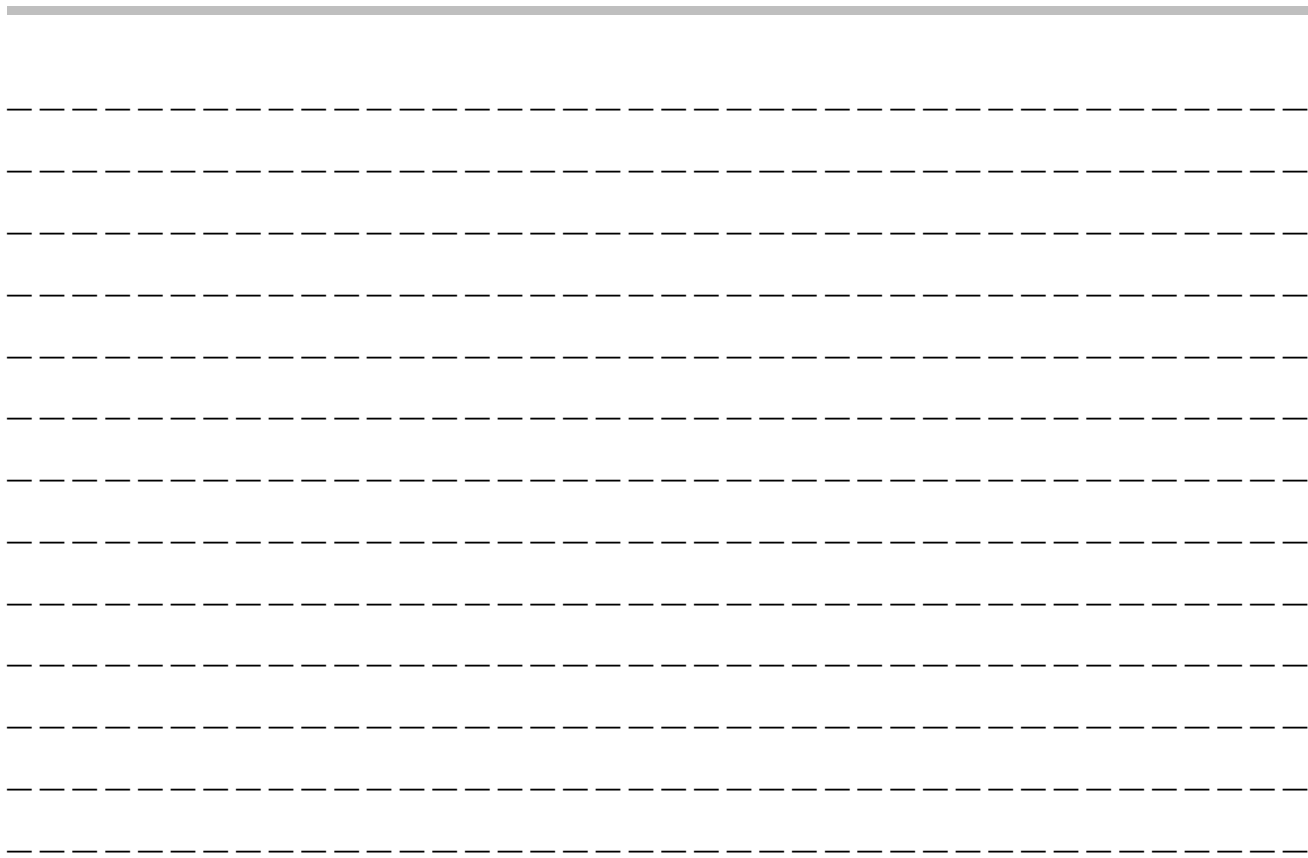

- 1) Vehicle identification number (under the floor carpet of the right-hand front seat)
- 2) Emission control label
- 3) Tire inflation pressure label
- 4) Certification label
- 5) Vehicle identification number plate
- 6) Model number label
- 7) Fuel label
- 8) Air conditioner label



Consumer information and Reporting safety defects

For U.S.A.	13-2		
Tire information	13-2		
Tire labeling	13-2		
Recommended tire inflation pressure	13-4		
Glossary of tire terminology	13-5		
Tire care – maintenance and safety practices	13-10		
Vehicle load limit – how to determine	13-10		
		Determining compatibility of tire and vehicle load capacities	13-12
		Adverse safety consequences of overloading on handling and stopping and on tires	13-12
		Steps for Determining Correct Load Limit	13-12
		Uniform tire quality grading standards	13-13
		Treadwear	13-13
		Traction AA, A, B, C	13-13
		Temperature A, B, C	13-14
		Reporting safety defects (U.S.A.)	13-14

For U.S.A.

The following information has been compiled according to Code of Federal Regulations "Title 49, Part 575".

Tire information

■ Tire labeling

Many markings (e.g. Tire size, Tire Identification Number or TIN) are placed on the sidewall of a tire by tire manufacturers. These markings can provide you with useful information on the tire.

▼ Tire size

Your vehicle comes equipped with P-Metric tire size. It is important to understand the sizing system in selecting the proper tire for your vehicles. Here is a brief review of the tire sizing system with a breakdown of its individual elements.

▽ P Metric

With the P-Metric system, Section Width is measured in millimeters. To convert millimeters into inches, divide by 25.4. The Aspect Ratio (Section Height divided by Section Width) helps provide more dimensional information about the tire size.

Example:

P **205** / **55** **R** **16**
(1) (2) (3) (4) (5)

- (1) P = Certain tire type used on light duty vehicles such as passenger cars
- (2) Section Width in millimeters
- (3) Aspect Ratio (= section height ÷ section width).
- (4) R = Radial Construction
- (5) Rim diameter in inches

▽ Load and Speed Rating Descriptions

The load and speed rating descriptions will appear following the size designation.

They provide two important facts about the tire. First, the number designation is its load index. Second, the letter designation indicates the tire's speed rating.

Example:

P 205 / 55 R 16 89 V
 Size designation (6) (7)

(6) Load Index: A numerical code which specifies the maximum load a tire can carry at the speed indicated by its speed symbol, at maximum inflation pressure.

For example, "90" means 1,323 lbs (600 kg), "89" means 1,278 lbs (580 kg).

 **WARNING**

Load indices apply only to the tire, not to the vehicle. Putting a load rated tire on any vehicle does not mean the vehicle can be loaded up to the tire's rated load.

(7) Speed Rating: An alphabetical system describing a tire's capability to travel at established and predetermined speeds.

For example, "V" means 149 mph (240 km/h)

 **WARNING**

- **Speed ratings apply only to the tire, not to the vehicle. Putting a speed rated tire on any vehicle does not mean the vehicle can be operated at the tire's rated speed.**
- **The speed rating is void if the tires are worn out, damaged, repaired, retreaded, or otherwise altered from their original condition. If tires are repaired, retreaded, or otherwise altered, they may not be suitable for original equipment tire designed loads and speeds.**

▼ **Tire Identification Number (TIN)**

Tire Identification Number (TIN) is marked on the intended outboard sidewall. The TIN is composed of four groups. Here is a brief review of the TIN with a breakdown of its individual elements.

DOT XX XX XXX XXXX

(1) (2) (3) (4)

(1) Manufacturer's Identification Mark

(2) Tire Size

(3) Tire Type Code

(4) Date of Manufacture

The first two figures identify the week, starting with "01" to represent the first full week of the calendar year; the second two figures represent the year. For example, 0101 means the 1st week of 2001.

▼ **Other markings**

The following makings are also placed on the sidewall.

▽ **Maximum permissible inflation pressure**

The maximum cold inflation pressure to which this tire may be inflated. For example, "300 kPa (44 PSI) MAX. PRESS"

▽ **Maximum load rating**

The load rating at the maximum permissible weight load for this tire. For example, "MAX. LOAD 580 kg (1279 LBS) @ 300 kPa (44 PSI) MAX. PRESS."

⚠ WARNING

Maximum load rating applies only to the tire, not to the vehicle. Putting a load rated tire on any vehicle does not mean the vehicle can be loaded up to the tire's rated load.

▽ **Construction type**

Applicable construction of this tire. For example, "TUBELESS STEEL BELTED RADIAL"

▽ **Construction**

The generic name of each cord material used in the plies (both sidewall and tread area) of this tire. For example, "PLIES: TREAD 2

STEEL + 2 POLYESTER SIDE-WALL 2 POLYESTER"

▽ **Uniform Tire Quality Grading (UTQG)**

For details, refer to "Uniform tire quality grading standards" 13-13.

■ **Recommended tire inflation pressure**

▼ **Recommended cold tire inflation pressure**

For recommended cold tire inflation pressure for your vehicle's tires, refer to "Tires" 12-8.

▼ **Vehicle placard**

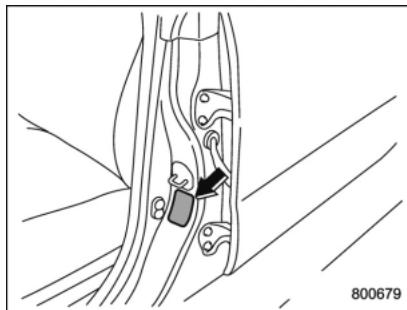

The vehicle placard is affixed to the driver's side B-pillar.

Example:

TIRE AND LOADING INFORMATION
RENSEIGNEMENTS SUR LES PNEUS ET LE CHARGEMENT

SEATING CAPACITY TOTAL X FRONT REAR
NOMBRE DE PLACES TOTAL X AVANT X ARRIERE X

The combined weight of occupants and cargo should never exceed XXX kg or XXX lb.
Le poids total des occupants et du chargement ne doit jamais dépasser XXX kg ou XXX lb.

TIRE PNEU	SIZE DIMENSION	COLD TIRE PRESS. RECOMMENDED PNEUS A FROID	SEE OWNER'S MANUAL FOR ADDITIONAL INFORMATION
FRONT AVANT	PXXXXXXX	XXXXX, XXPSI	VOIR LE MANUEL DE L'USAGER POUR PLUS DE RENSEIGNEMENTS
REAR ARRIERE	PXXXXXXX	XXXXX, XXPSI	
SPARE DE SECOURS	TXXXXXX	XXXXX, XXPSI	

D00155

The vehicle placard shows original tire size, recommended cold tire inflation pressure on each tire at maximum loaded vehicle weight, seating capacity and loading information.

▼ **Adverse safety consequences of under-inflation**

Driving at high speeds with excessively low tire pressures can cause the tires to flex severely and to rapidly become hot. A sharp in-

crease in temperature could cause tread separation, and failure of the tire(s). Possible resulting loss of vehicle control could lead to an accident.

▼ **Measuring and adjusting air pressure to achieve proper inflation**

Check and, if necessary, adjust the pressure of each tire (including the spare) at least once a month and before any long journey. Check the tire pressures when the tires are cold. Use a pressure gauge to adjust the tire pressures to the specific values. Driving even a short distance warms up the tires and increases the tire pressures. Also, the tire pressures are affected by the outside temperature. It is best to check tire pressure outdoors before driving the vehicle. When a tire becomes warm, the air inside it expands, causing the tire pressure to increase. Be careful not to mistakenly release air from a warm tire to reduce its pressure.

■ **Glossary of tire terminology**

● **Accessory weight**

The combined weight (in excess of those standard items which may be replaced) of automatic transmission, power steering, power brakes, power windows, power seats, radio, and heater, to the extent that these items are available as factory-installed equipment (whether installed or not).

● **Bead**

The part of the tire that is made of steel wires, wrapped or reinforced by ply cords and that is shaped to fit the rim.

● **Bead separation**

A breakdown of the bond between components in the bead.

● **Bias ply tire**

A pneumatic tire in which the ply cords that extend to the beads are laid at alternate angles substantially less than 90 degrees to the centerline of the tread.

● **Carcass**

The tire structure, except tread and

sidewall rubber which, when inflated, bears the load.

● **Chunking**

The breaking away of pieces of the tread or sidewall.

● **Cold tire pressure**

The pressure in a tire that has been driven less than 1 mile or has been standing for three hours or more.

● **Cord**

The strands forming the plies in the tire.

● **Cord separation**

The parting of cords from adjacent rubber compounds.

● **Cracking**

Any parting within the tread, sidewall, or inner liner of the tire extending to cord material.

● **Curb weight**

The weight of a motor vehicle with standard equipment including the maximum capacity of fuel, oil and coolant, and if so equipped, air conditioning and additional weight optional engine.

- **Extra load tire**

A tire designed to operate at higher loads and higher inflation pressure than the corresponding standard tire.

- **Groove**

The space between two adjacent tread ribs.

- **Innerliner**

The layer(s) forming the inside surface of a tubeless tire that contains the inflating medium within the tire.

- **Innerliner separation**

The parting of the innerliner from cord material in the carcass.

- **Intended outboard sidewall**

(1) The sidewall that contains a whitewall, bears white lettering or bears manufacturer, brand, and/or model name molding that is higher or deeper than the same molding on the other sidewall of the tire, or

(2) The outward facing sidewall of an asymmetrical tire that has a particular side that must always face outward when mount-

ing on a vehicle.

- **Light truck (LT) tire**

A tire designated by its manufacturer as primarily intended for use on lightweight trucks or multipurpose passenger vehicles.

- **Load rating**

The maximum load that a tire is rated to carry for a given inflation pressure.

- **Maximum inflation pressure**

The maximum cold inflation pressure to which a tire may be inflated.

- **Maximum load rating**

The load rating for a tire at the maximum permissible inflation pressure for that tire.

- **Maximum loaded vehicle weight**

The sum of:

- (a) Curb weight
- (b) Accessory weight
- (c) Vehicle capacity weight
- (d) Production options weight

- **Maximum permissible inflation pressure**

The maximum cold inflation pressure to which a tire may be inflated.

- **Measuring rim**

The rim on which a tire is fitted for physical dimension requirements.

- **Normal occupant weight**

150 lbs (68 kg) times the number of occupants specified in the second column of Table 1 that is appended to the end of this section.

- **Occupant distribution**

Distribution of occupants in a vehicle as specified in the third column of Table 1 that is appended to the end of this section.

- **Open splice**

Any parting at any junction of tread, sidewall, or innerliner that extends to cord material.

- **Outer diameter**

The overall diameter of an inflated new tire.

- **Overall width**

The linear distance between the exteriors of the sidewalls of an inflated tire, including elevations due to labeling, decorations, or protective bands or ribs.

- **Passenger car tire**

A tire intended for use on passenger cars, multipurpose passenger vehicles, and trucks, that have a gross vehicle weight rating (GVWR) of 10,000 lbs (4,535 kg) or less.

- **Ply**

A layer of rubber-coated parallel cords.

- **Ply separation**

A parting of rubber compound between adjacent plies.

- **Pneumatic tire**

A mechanical device made of rubber, chemicals, fabric and steel or other materials, that, when mounted on an automotive wheel, provides the traction and contains the gas or fluid that sustains the load.

- **Production options weight**

The combined weight of those installed regular production options weighing over 5.1 lbs (2.3 kg) in excess of those standard items which they replace, not previously considered in curb weight or acces-

sory weight, including heavy duty brakes, ride levelers, roof rack, heavy duty battery, and special trim.

- **Radial ply tire**

A pneumatic tire in which the ply cords that extend to the beads are laid at substantially 90 degrees to the centerline of the tread.

- **Recommended inflation pressure**

The cold inflation pressure recommended by a vehicle manufacturer.

- **Reinforced tire**

A tire designed to operate at higher loads and at higher inflation pressures than the corresponding standard tire.

- **Rim**

A metal support for a tire or a tire and tube assembly upon which the tire beads are seated.

- **Rim diameter**

Nominal diameter of the bead seat.

- **Rim size designation**

Rim diameter and width.

- **Rim type designation**

The industry of manufacturer's designation for a rim by style or code.

- **Rim width**

Nominal distance between rim flanges.

- **Section width**

The linear distance between the exteriors of the sidewalls of an inflated tire, excluding elevations due to labeling, decoration, or protective bands.

- **Sidewall**

That portion of a tire between the tread and bead.

- **Sidewall separation**

The parting of the rubber compound from the cord material in the sidewall.

- **Test rim**

The rim on which a tire is fitted for testing, and it may be any rim listed as appropriate for use with that tire.

- **Tread**

That portion of a tire that comes into contact with the road.

- **Tread rib**

A tread section running circumferentially around a tire.

- **Tread separation**

Pulling away of the tread from the tire carcass.

- **Treadwear indicators (TWI)**

The projections within the principal grooves designed to give a visual indication of the degrees of wear of the tread.

- **Vehicle capacity weight**

The rated cargo and luggage load plus 150 lbs (68 kg) times the vehicle's designated seating capacity.

- **Vehicle maximum load on the tire**

Load on an individual tire that is determined by distributing to each axle its share of the maximum loaded vehicle weight and dividing by two.

- **Vehicle normal load on the tire**

Load on an individual tire that is determined by distributing to each axle its share of the curb weight,

accessory weight, and normal occupant weight (distributed in accordance with Table 1 that is appended to the end of this section) and dividing by 2.

- **Wheel-holding fixture**

The fixture used to hold the wheel and tire assembly securely during testing.

Table 1 — Occupant loading and distribution for vehicle normal load for various designated seating capacities

Designated seating capacity, number of occupants	Vehicle normal load, number of occupants	Occupant distribution in a normally loaded vehicle
2 through 4	2	2 in front.
5 through 10	3	2 in front, 1 in second seat.
11 through 15	5	2 in front, 1 in second seat, 1 in third seat, 1 in fourth seat.
16 through 22	7	2 in front, 2 in second seat, 2 in third seat, 1 in fourth seat.

■ **Tire care – maintenance and safety practices**

- Check on a daily basis that the tires are free from serious damage, nails, and stones. At the same time, check the tires for abnormal wear.
- Inspect the tire tread regularly and replace the tires before their tread wear indicators become visible. When a tire's tread wear indicator becomes visible, the tire is worn beyond the acceptable limit and must be replaced immediately. With a tire in this condition, driving at even low speeds in wet weather can cause the vehicle to hydroplane. Possible resulting loss of vehicle control can lead to an accident.
- Replace any damaged or unevenly worn tires at the time of rotation. For information about the tire rotation order, refer to "Tire rotation" ¶ 11-35. After tire rotation, adjust the tire pressures and make sure the wheel nuts are correctly tightened. For information about

the tightening torque and tightening sequence for the wheel nuts, refer to "Flat tires" ¶ 9-4.

■ **Vehicle load limit – how to determine**

The load capacity of your vehicle is determined by weight, not by available cargo space. The load limit of your vehicle is shown on the vehicle placard attached to the driver's side B-pillar. Locate the statement "The combined weight of occupants and cargo should never exceed XXX kg or XXX lbs" on your vehicle's placard.

The vehicle placard also shows seating capacity of your vehicle.

The total load capacity includes the total weight of driver and all passengers and their belongings, any cargo, any optional equipment such as a roof rack or bike carrier, etc. Therefore cargo capacity can be calculated by the following method.

Cargo capacity = Load limit – (total

weight of occupants + total weight of optional equipment)

For information about vehicle loading, refer to "Loading your vehicle" ¶ 8-10.

▼ **Calculating total and load capacities varying seating configurations**

Calculate the available load capacity as shown in the following examples:

Example 1A

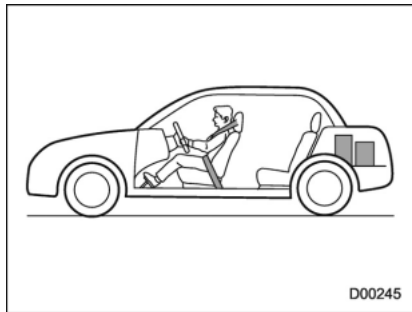

Vehicle capacity weight of the vehicle is 900 lbs (408 kg), which is indicated on the vehicle placard with the statement “The combined weight of occupants and cargo should never exceed 900 lbs or 408 kg”.

For example, if the vehicle has one

occupant weighing 154 lbs (70 kg) plus cargo weighing 662 lbs (300 kg).

1. Calculate the total weight.

Total weight

$$= \frac{154 \text{ lbs (70 kg)}}{\text{(Occupant)}} + \frac{662 \text{ lbs (300 kg)}}{\text{(Cargo)}}$$

$$= \mathbf{816 \text{ lbs (370 kg)}}$$

2. Calculate the available load capacity by subtracting the total weight from the vehicle capacity weight of 900 lbs (408 kg).

Available Load Capacity

$$= \frac{900 \text{ lbs (408 kg)}}{\text{(Vehicle capacity weight)}} - \frac{816 \text{ lbs (370 kg)}}{\text{(Total weight)}}$$

$$= \mathbf{84 \text{ lbs (38 kg)}}$$

3. The result of step 2 shows that a further 84 lbs (38 kg) of cargo can be carried.

Example 1B

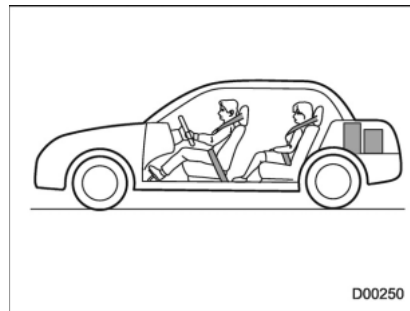

For example, if a person weighing 176 lbs (80 kg) now enters the same vehicle (bringing the number of occupants to two), the calculations are as follows.

1. Calculate the total weight.

Total weight

$$= \frac{154 \text{ lbs (70 kg)}}{\text{(Occupant)}} + \frac{176 \text{ lbs (80 kg)}}{\text{(Occupant)}}$$

$$+ \frac{662 \text{ lbs (300 kg)}}{\text{(Cargo)}}$$

$$= \mathbf{992 \text{ lbs (450 kg)}}$$

2. Calculate the available load capacity.

Available Load Capacity

$$= \frac{900 \text{ lbs (408 kg)}}{\text{(Vehicle capacity weight)}} - \frac{992 \text{ lbs (450 kg)}}{\text{(Total weight)}}$$

$$= -92 \text{ lbs (-42 kg)}$$

3. The total weight now exceeds the capacity weight by 92 lbs (42 kg), so the cargo weight must be reduced by 92 lbs (42 kg) or more.

■ Determining compatibility of tire and vehicle load capacities

The sum of four tires' maximum load ratings must exceed the maximum loaded vehicle weight ("GVWR"). In addition, sum of the maximum load ratings of two front tires and of two rear tires must exceed each axle's maximum loaded capacity ("GAWR"). Original equipment tires are designed to fulfill those conditions.

The maximum loaded vehicle

weight is referred to Gross Vehicle Weight Rating (GVWR). And each axle's maximum loaded capacity is referred to Gross Axle Weight Rating (GAWR). The GVWR and each axle's GAWR are shown on the vehicle certification label affixed to the driver's door.

The GVWR and front and rear GAWRs are determined by not only the maximum load rating of tires but also loaded capacities of the vehicle's suspension, axles and other parts of the body.

Therefore, this means that the vehicle cannot necessarily be loaded up to the tire's maximum load rating on the tire sidewall.

■ Adverse safety consequences of overloading on handling and stopping and on tires

Overloading could affect vehicle handling, stopping distance, and vehicle and tire performance in the following ways. This could lead to

an accident and possibly result in severe personal injury.

- Vehicle stability will deteriorate.
- Heavy and/or high-mounted loads could increase the risk of rollover.
- Stopping distance will increase.
- Brakes could overheat and fail.
- Suspension, bearings, axles and other body parts could break or experience accelerated wear that will shorten vehicle life.
- Tires could fail.
- Tread separation could occur.
- Tire could separate from its rim.

■ Steps for Determining Correct Load Limit

1. Locate the statement "The combined weight of occupants and cargo should never exceed XXX kg or XXX lbs." on your vehicle's placard.
2. Determine the combined weight of the driver and passengers that will be riding in your vehicle.
3. Subtract the combined weight of

the driver and passengers from XXX kg or XXX lbs.

4. The resulting figure equals the available amount of cargo and luggage load capacity. For example, if the "XXX" amount equals 1400 lbs. and there will be five 150 lb passengers in your vehicle, the amount of available cargo and luggage load capacity is 650 lbs. ($1400 - 750 (5 \times 150) = 650$ lbs.)

5. Determine the combined weight of luggage and cargo being loaded on the vehicle. That weight may not safely exceed the available cargo and luggage load capacity calculated in Step 4.

Uniform tire quality grading standards

This information indicates the relative performance of passenger car tires in the area of treadwear, traction, and temperature resistance. This is to aid the consumer in making an informed choice in the purchase of tires.

Quality grades can be found where applicable on the tire sidewall between tread shoulder and maximum section width. For example:

Treadwear 200 Traction AA Temperature A

The quality grades apply to new pneumatic tires for use on passenger cars. However, they do not apply to deep tread, winter type snow tires, space-saver or temporary use spare tires, tires with nominal rim diameters of 12 inches or less, or to some limited production tires.

All passenger car tires must con-

form to Federal Safety Requirements in addition to these grades.

■ Treadwear

The treadwear grade is a comparative rating based on the wear rate of the tire when tested under controlled conditions on a specified government test course.

For example, a tire graded 150 would wear one and one-half (1-1/2) times as well on the government course as a tire graded 100. The relative performance of tires depends upon the actual conditions of their use, however, and may depart significantly from the norm due to variations in driving habits, service practices and differences in road characteristics and climate.

■ Traction AA, A, B, C

The traction grades, from highest to lowest, are AA, A, B and C. Those grades represent the tire's ability to stop on wet pavement as measured under controlled conditions on spe-

cified government test surfaces of asphalt and concrete. A tire marked C may have poor traction performance.

 **WARNING**

The traction grade assigned to this tire is based on straight-ahead braking traction tests, and does not include acceleration, cornering, hydroplaning, or peak traction characteristics.

■ **Temperature A, B, C**

The temperature grades are A (the highest), B, and C, representing the tire's resistance to the generation of heat and its ability to dissipate heat when tested under controlled conditions on a specified indoor laboratory test wheel. Sustained high temperature can cause the material of the tire to degenerate and reduce tire life, and excessive temperature can lead to sudden tire failure. The

grade C corresponds to a level of performance which all passenger car tires must meet under the Federal Motor Vehicle Safety Standards No. 109. Grades B and A represent higher levels of performance on the laboratory test wheel than the minimum required by law.

 **WARNING**

The temperature grade for this tire is established for a tire that is properly inflated and not overloaded. Excessive speed, underinflation, or excessive loading, either separately or in combination, can cause heat buildup and possible tire failure.

Reporting safety defects (U.S.A.)

If you believe that your vehicle has a defect which could cause a crash or could cause injury or death, you should immediately inform the National Highway Traffic Safety Administration (NHTSA) in addition to notifying Subaru of America, Inc.

If NHTSA receives similar complaints, it may open an investigation, and if it finds that a safety defect exists in a group of vehicles, it may order a recall and remedy campaign. However, NHTSA cannot become involved in individual problems between you, your dealer, or Subaru of America, Inc. To contact NHTSA, you may call the Vehicle Safety Hotline toll-free at 1-888-327-4236 (TTY: 1-800-424-9153); go to <http://www.safercar.gov>; or write to: Administrator, NHTSA, 1200

New Jersey Avenue, SE, West Building, Washington, DC 20590. You can also obtain other information about motor vehicle safety from <http://www.safercar.gov>.

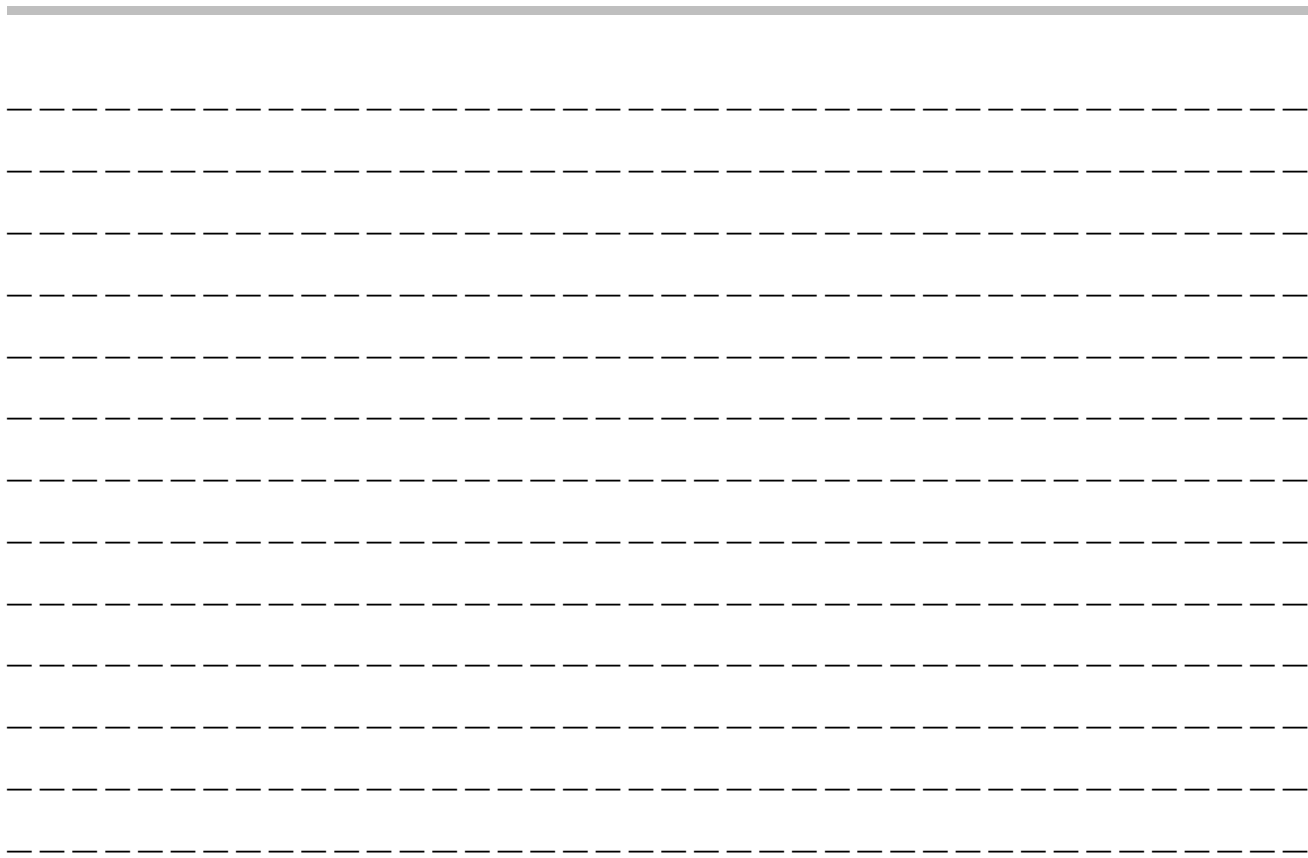

- A**
- Abbreviation 2
 - ABS (Anti-lock Brake System) 7-35
 - Warning light 3-20
 - Access key 2-8
 - Warning light 3-26
 - Accessories 5-4, 11-43
 - Accessory power outlet 6-7
 - Air cleaner element 11-18
 - Air conditioner
 - Automatic climate control 4-5
 - Manual climate control 4-6
 - Air flow mode 4-6
 - Alarm system 2-21
 - All-Wheel Drive warning light 3-22
 - Aluminum wheel 11-37
 - Cleaning 10-3
 - Antenna system 5-3
 - Anti-lock Brake System (ABS) 7-35
 - Arming the system 2-23
 - Ashtray 6-9
 - AT OIL TEMP warning light 3-18
 - Audio
 - Antenna system 5-3
 - Auxiliary input jack 5-22
 - Bluetooth® audio 5-33
 - CD player operation 5-17
 - Control button 5-31
 - FM/AM radio operation 5-10
 - iPod® operations 5-25
 - Power and audio controls 5-7
 - Satellite radio operations 5-15
 - Set 5-4
 - USB storage device operations 5-25
 - Auto-dimming mirror/compass 3-106, 3-107
 - Automatic headlight beam leveler 3-102
 - Warning light 3-32
 - Automatic transmission
 - Oil temperature warning light (AT OIL TEMP) 3-18
 - Automatic/Emergency Locking Retractor (A/ELR) 1-12
 - Auxiliary input jack 5-22
- B**
- Battery 11-40
 - Drainage prevention function 2-6
 - Jump starting 9-9
 - Replacement (access key) 11-49
 - Replacement (keyless access with push-button start system) 2-15, 11-49
 - Replacement (remote keyless entry system) 2-20, 11-50
 - Replacement (transmitter) 11-50
 - Bluetooth® audio 5-33
 - Booster seat 1-27
 - Bottle holder 6-7
 - Brake
 - Assist 7-35
 - Booster 7-34, 11-26
 - Fluid 11-24, 12-7
 - Pad and lining 11-29
 - Parking 7-43, 11-29
 - Pedal 11-27
 - System 7-34

- Brake pedal
 - Free play 11-27
 - Reserve distance 11-27
- Brake system 7-34
 - Warning light 3-20
- Braking 7-34
 - Tips 7-34
- Breaking-in of new brake pads and linings 11-29
- Bulb
 - Chart 12-15
 - Replacing 11-43
- C**
- Catalytic converter 8-3
- Center
 - Console 6-5
- Changing
 - Coolant 11-18
 - Flat tire 9-4
 - Oil and oil filter 11-14
- Charge warning light 3-17
- CHECK ENGINE warning light/Malfunction indicator light 3-16
- Checking
 - Brake pedal free play 11-27
 - Brake pedal reserve distance 11-27
 - Clutch function 11-27
 - Clutch pedal free play 11-28
 - Coolant level 11-17
 - Fluid level (brake fluid) 11-24
 - Fluid level (clutch fluid) 11-25
 - Fluid level (power steering fluid) 11-23
 - Fluid level (washer fluid) 11-37
 - Oil level (engine oil) 11-12
- Child restraint systems 1-20
 - Installation of a booster seat 1-27
 - Installation with A/ELR seatbelt 1-23
 - Lower and tether anchorages 1-28
 - Top tether anchorages 1-31
- Child safety 4
 - Locks 2-28
- Chime
 - Key 3-5
 - Light 3-98
 - Seatbelt 3-13
- Cigarette lighter 6-8
- Cleaning
 - Aluminum wheels 10-3
 - Interior 10-5
 - Ventilation grille 4-9
- Climate control system 4-3
 - Automatic 4-5
 - Manual 4-6
- Clock 3-45, 3-49
- Clutch
 - Fluid 11-25, 12-7
 - Pedal 11-27
- Coat hook 6-11
- Compass 3-106, 3-107
- Console 6-5
- Continuously variable transmission (CVT) 7-23
 - Fluid 11-22

Coolant.....	11-17, 12-7
Cooling system.....	11-16
Corrosion protection.....	10-4
Cruise control.....	7-47
Indicator light.....	3-32
Set indicator light.....	3-32, 7-48
Cup holder.....	6-5
Front passenger's.....	6-5
Rear passenger's.....	6-6
D	
Daytime running light system.....	3-100
Defogger.....	3-114
Defrosting.....	4-9
Deicer.....	3-114
Differential gear oil	
Front.....	11-22, 12-6
Rear.....	11-23, 12-6
Dimensions.....	12-2
Disarming the alarm system.....	2-25
Disc brake pad wear warning indicators.....	7-35
Dome light.....	6-2
Door	
Locks.....	2-4
Open warning light.....	3-22
Double trip meter.....	3-9
Drive belts.....	11-21
Driver's Control Center Differential.....	7-19
Auto indicator light.....	3-32
Indicator light.....	3-33

Driving	
All-Wheel Drive warning light.....	3-22
AWD vehicles.....	8-5
Car phone/cell phone.....	6
Drinking.....	5
Drugs.....	6
Foreign countries.....	8-4
Pets.....	7
Snowy and icy roads.....	8-8
Tips.....	7-18, 7-28, 8-2, 8-5
Tired or sleepy.....	6
Winter.....	8-6

E

ECO gauge.....	3-11
Electrical system.....	12-8
Electronic Brake Force Distribution (EBD) system... 3-21, 7-36	
Emergency Locking Retractor (ELR).....	1-12
Engine	
Compartment overview.....	11-10
Coolant.....	11-17, 12-7
Exhaust gas (carbon monoxide).....	5, 8-2
Hood.....	11-8
Low oil level warning light.....	3-17
Oil.....	11-12, 12-4
Overheating.....	9-11
Starting & stopping.....	7-9, 7-12
Event data recorder.....	8
Exterior care.....	10-2

F

Flat tires	9-4
Floor mat	6-10
Fluid level	
Brake	11-24
Clutch	11-25
Continuously variable transmission	11-22
Power steering	11-23
Fog light	3-102
Bulb	11-46, 12-15
Indicator light	3-32
Switch	3-102
Front	
Differential gear oil	11-22, 12-6
Fog light	3-102, 11-46
Fog light indicator light	3-32
Seatbelt pretensioners	1-16
Front fog light	3-102
Switch	3-102
Front seats	1-2
Forward and backward adjustment	1-4
Head restraint adjustment	1-5
Power seat	1-5
Reclining	1-4
Seat height adjustment (driver's seat)	1-4
Fuel	7-3
Consumption indicator	3-49, 3-51
Economy hints	8-2
Filler lid and cap	7-5
Gauge	3-10
Requirements	7-3, 12-3

Fuses	11-41
Fuses and circuits	12-9

G

GAWR (Gross Axle Weight Rating)	8-12
Glove box	6-4
GVWR (Gross Vehicle Weight Rating)	8-12

H

Hands-free system	5-36
Hazard warning flasher	3-8, 9-2
Head restraint adjustment	
Front seat	1-5
Rear seat	1-8
Headlight	
Beam leveler	3-102
Bulb replacement	11-43
Bulb replacing	11-43
Bulb wattage	12-15
Control switch	3-98
Flasher	3-100
Indicator light	3-32
HID headlights	11-43
High beam indicator light	3-32
High/low beam change (dimmer)	3-100
Hill start assist	7-44, 11-28
OFF indicator light	3-22
To activate/deactivate	7-46
Warning light	3-22
HomeLink®	3-107

- Hook
 Coat 6-11
 Towing and tie-down 9-12
Horn 3-116
Hose and connections 11-16
- I**
Ignition switch 3-4
 Light 3-6
Illumination brightness control 3-101
Immobilizer 2-2
 Indicator light (security indicator light) 3-30
Indicator light
 Cruise control 3-32
 Cruise control set 3-32
 Front fog light 3-32
 Headlight 3-32
 High beam 3-32
 Hill start assist OFF 3-22
 Immobilizer 3-30
 REV 3-34
 Security 3-30
 Select lever/Gear position 3-31
 Shift-up 3-31
 SI-DRIVE 3-31
 Traction control OFF 3-25
 Turn signal 3-32
 Vehicle Dynamics Control OFF 3-25
 Vehicle Dynamics Control operation 3-23, 3-24
Inside mirror 3-106
Interior lights 6-2
- Internal trunk lid release handle 2-33
iPod® operations 5-25
- J**
Jack-up point 9-4
Jump starting 9-9
- K**
Key 2-2
 Number 2-2
 Reminder chime 3-5
 Replacement 2-3
Keyless access entry function 2-11
Keyless access with push-button start system 2-8
 Disabling keyless access functions 2-15
 Locking and unlocking doors 2-11
 Opening trunk lid 2-13
 Warning chimes and warning light 2-14, 3-26
 When access key does not operate properly 2-15, 3-8, 7-14, 9-16
- L**
Lap belt pretensioner 1-18
Leather seat materials 10-5
License plate light 11-48
Light
 Control switch 3-98
 Daytime running 3-100
 Dome 6-2
 Front fog 3-102, 11-46
 Front position 3-99, 3-102

- Front side marker..... 12-15
 - Ignition switch..... 3-6
 - License plate..... 11-48
 - Map 6-2
 - Rear combination..... 11-47
 - Rear side marker light 11-47
 - Stop light 11-47
 - Tail light..... 11-47
 - Turn signal..... 3-101, 11-47
 - Limited slip differential (LSD)..... 7-32
 - Loading your vehicle 8-10
 - Low fuel warning light..... 3-21
 - Low tire pressure warning light 3-18
 - Lower and tether anchorage..... 1-28
 - LSD (Limited slip differential)..... 7-32
- M**
- Maintenance
 - Precautions 11-3
 - Schedule 11-3
 - Seatbelt 1-15
 - Tips..... 11-5
 - Tools 9-3
 - Malfunction indicator light (check engine warning light) ... 3-16
 - Manual
 - Climate control 4-5, 4-6
 - Mode (continuously variable transmission) 7-25
 - Seat 1-4
 - Transmission 7-16
 - Transmission oil..... 11-22, 12-6
 - Map light..... 6-2
- Meters and gauges..... 3-8
 - Mirror defogger 3-114
 - Mirrors 3-106
 - Moonroof..... 2-34, 9-17
 - Multi function display..... 3-45
- N**
- New vehicle break-in driving 8-2
- O**
- Odometer 3-9
 - Oil filter 11-14
 - Oil level
 - Engine 11-12
 - Front differential gear 11-22
 - Manual transmission 11-22
 - Rear differential gear 11-23
 - Warning light..... 3-17
 - Oil pressure warning light 3-17
 - Outside
 - Mirror defogger 3-114
 - Mirrors 3-113
 - Temperature indicator..... 3-49
 - Overheating engine 9-11
- P**
- Parking
 - Brake 7-43
 - Brake stroke 11-29
 - Tips 7-43
 - Periodic inspections 8-4

- Petrol fuel 7-3
- Power
- Door locking switch 2-7
 - Outlets 6-7
 - Outside mirrors 3-113, 3-114
 - Seat 1-5
 - Steering 7-33
 - Steering fluid 11-23, 12-7
 - Steering warning light 3-22
- Precautions against vehicle modification 1-20, 1-58
- Preparing to drive 7-8
- Push-button
- Ignition switch 3-6
 - Starting and stopping engine 7-9, 7-12
- R**
- Rear
- Combination lights 11-47
 - Differential gear oil 11-23, 12-6
 - Limited slip differential 7-32
 - Turn signal light 11-47
- Rear differential
- Oil temperature warning light 3-18
- Rear seat 1-7
- Folding down 1-9
 - Head restraint adjustment 1-8
- Rear view camera 6-12
- Rear window
- Defogger 3-114
- Recommended
- Brake fluid 12-7
 - Clutch fluid 11-25, 12-7
 - Engine oil 12-4
 - Front differential gear oil 12-6
 - Manual transmission oil 12-6
 - Power steering fluid 12-7
 - Rear differential gear oil 12-6
 - Spark plugs 12-8
- Refueling 7-5
- Remote engine start system 7-14
- Remote keyless entry system 2-17
- Replacement
- Brake pad and lining 11-28
 - Wiper blades 11-38
- Replacing
- Access key battery 11-49
 - Air cleaner element 11-18
 - Battery (keyless access with push-button start system) 2-15, 11-49
 - Battery (remote keyless entry system) 2-20, 11-50
 - Lost transmitters (remote keyless entry system) 2-20
 - Remote keyless entry transmitter battery 11-50
- Replacing bulbs 11-43, 12-15
- Front fog light 11-46
 - Headlight 11-43
 - License plate light 11-48
 - Rear combination light 11-47
 - Rear side marker light 11-47
 - Rear turn signal light 11-47
 - Stop light 11-47
 - Tail light 11-47
- REV indicator light and buzzer 3-12

- Rocking the vehicle 8-10
- S**
- Safety
 - Precautions when driving 3
 - Symbol 2
 - Warnings 2
- Satellite radio 5-15
- Seat
 - Fabric 10-5
 - Front 1-2
 - Heater 1-6
 - Height adjustment 1-4
 - Power 1-5
 - Rear 1-7
- Seatbelt 3, 1-11
 - Fastening 1-13
 - Maintenance 1-15
 - Pretensioners 1-16
 - Safety tips 1-11
 - Warning light and chime 3-13
- Security
 - Alarm system 2-21
 - Immobilizer 2-2
 - Indicator light 3-30
 - Shock sensors 2-27
- Select lever
 - Position indicator 3-31
 - Shift lock function 7-27
- Shift-up indicator light 3-31
- Shock sensors 2-27
- Shoulder pretensioners 1-16
- SI-DRIVE
 - Indicator light 3-31
 - SI-DRIVE mode 7-28
- Snow tires 8-9, 11-30
- Snowy and icy roads 8-8
- Sounding a panic alarm 2-20
- Spark plugs 11-20, 12-8
- Specifications 12-2
- Speedometer 3-9
- SRS
 - Curtain airbag 1-49
 - Frontal airbag 1-37
 - Side airbag 1-49
- SRS airbag (Supplemental Restraint System airbag) ... 3, 1-32
- SRS airbag system
 - Monitors 1-56
 - Servicing 1-57
 - Warning light 3-15
- Starting & stopping engine 7-9, 7-12
- State emission testing (U.S. only) 7-7
- Steering wheel
 - Power 7-33
 - Tilt/telescopic 3-115
- Stop light 11-47
- Storage compartment 6-4
- Sun shade 2-36
- Sun visors 6-3
- Supplemental Restraint System airbag (SRS) 1-32
- Synthetic leather upholstery 10-5

- T**
- Tachometer 3-10
 - Temperature gauge 3-11
 - Temperature warning light
 - AT OIL TEMP 3-18
 - Rear differential oil 3-18
 - Temporary spare tire 9-2, 12-8
 - Tether (child restraint system) 1-28, 1-31
 - Tie-down hooks 9-12
 - Tire 11-30, 12-8
 - Chains 8-10
 - Inspection 11-31
 - Pressures and wear 11-32
 - Replacement 11-35
 - Rotation 11-35
 - Size and pressure 12-8
 - Types 11-30
 - Tire pressure monitoring system (TPMS) 7-41, 9-8, 11-30
 - Warning light 3-18
 - Tires and wheels 11-30
 - Tools 9-3
 - Top tether anchorages 1-28, 1-31
 - Towing 9-12
 - All wheels on the ground 9-15
 - Flat-bed truck 9-14
 - Hooks 9-12
 - Trailer
 - Towing 8-12
 - Trip meter 3-9
 - Trunk lid 2-32
 - Release handle 2-33
- Turn signal**
- Indicator lights 3-32
 - Lever 3-101
- U**
- Under-floor storage compartment 6-11
 - USB storage device operations 5-25
- V**
- Valet mode 2-26
 - Vanity mirror 6-4
 - Vehicle
 - Capacity weight 8-11
 - Identification 12-17
 - Symbols 3
 - Vehicle Dynamics Control
 - OFF indicator light 3-25
 - OFF switch 7-40
 - Operation indicator light 3-23, 3-24
 - System 7-38
 - Warning light 3-23
 - Ventilator 4-2
- W**
- Warning and indicator lights 3-13
 - Warning chimes
 - Keyless access with push-button start system 3-26
 - Warning light
 - ABS 3-20
 - Access key 3-26
 - All-Wheel Drive 3-22

AT OIL TEMP	3-18	Wiper and washer switches	3-104
Automatic headlight beam leveler.....	3-32	Wiper blades.....	11-39
Brake system	3-20	Wiper deicer	3-114
Charge	3-17	Winter	
CHECK ENGINE	3-16	Driving	8-6
Door open.....	3-22	Tires	8-9, 11-30
Driver's Control Center Differential	3-33	Wiper and washer	3-103
Engine low oil level	3-17	Wiper deicer	3-114
Hill start assist.....	3-22		
Keyless access with push-button start system	3-26		
Low fuel.....	3-21		
Low tire pressure	3-18		
Oil pressure	3-17		
Power steering	3-22		
Rear differential oil temperature	3-18		
Seatbelt	3-13		
SRS airbag system	3-15		
Vehicle Dynamics Control	3-23		
Windshield washer fluid	3-17		
Warranties	1		
Washing	10-2		
Waxing and polishing	10-3		
Wear indicators.....	11-34		
Wheel			
Aluminum.....	11-37		
Balance	11-34		
Nut tightening torque	9-4, 12-8		
Replacement	11-36		
Windows	2-28		
Windshield			
Washer fluid	11-37		

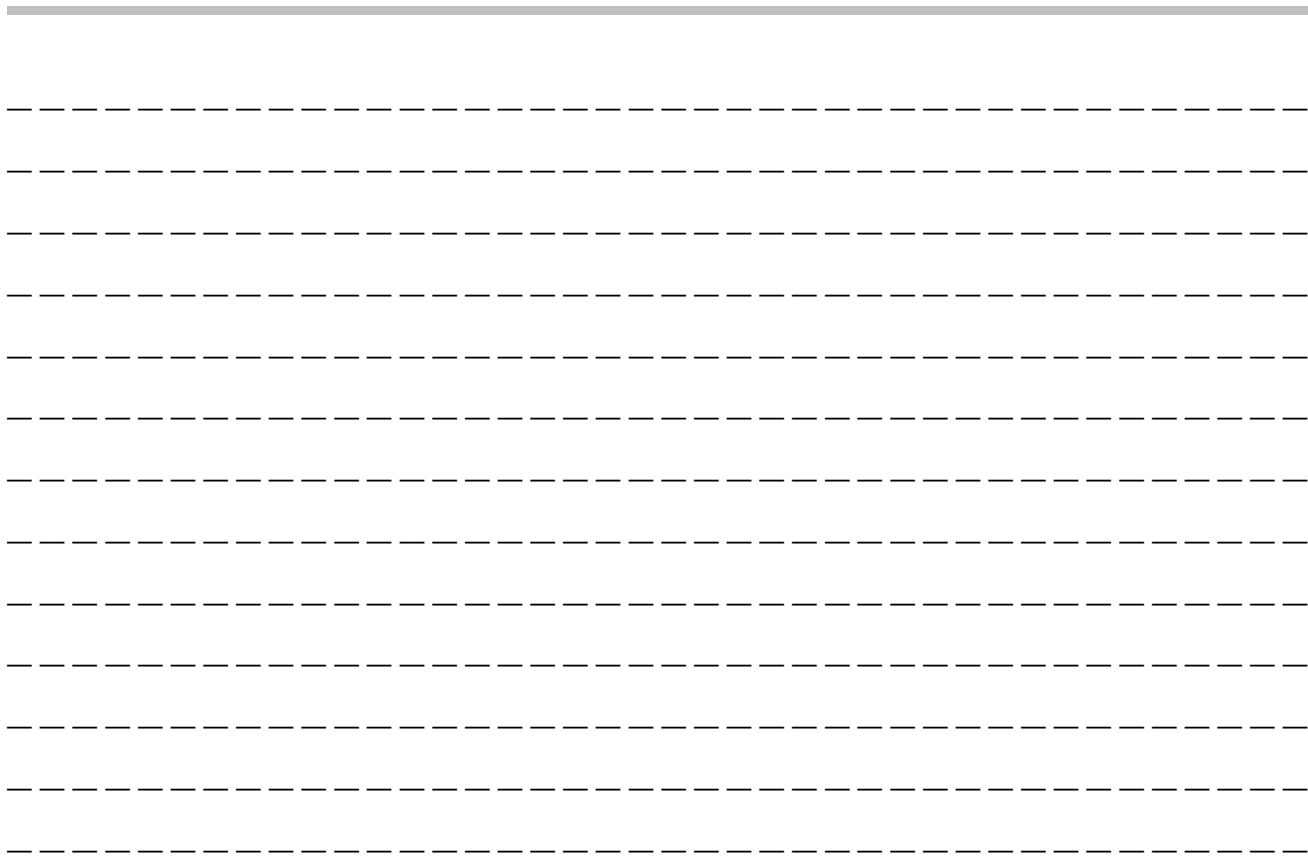

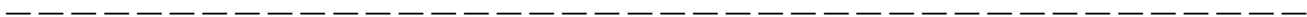
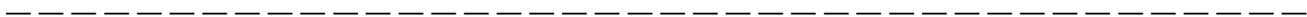
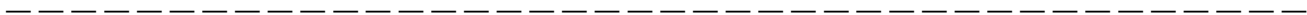
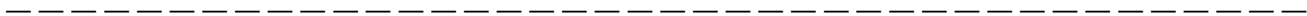
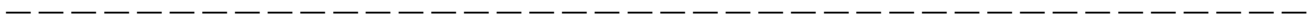
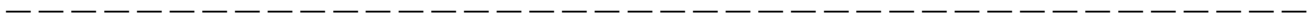
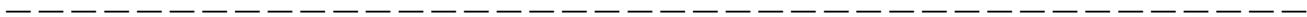
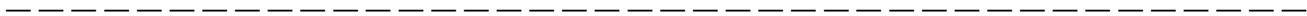
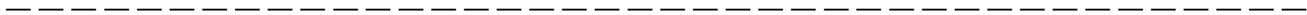

GAS STATION REFERENCE

■ Fuel:

▼ STI

The engine is designed to operate at maximum performance using **unleaded gasoline** with an octane rating of **93 AKI (98 RON) or higher**. If 93 AKI (98 RON) fuel is not readily available in your area, unleaded gasoline with an octane rating of 91 AKI (95 RON) may be used with no detriment to engine durability or driveability. However, you may notice a slight decrease in maximum engine performance while using 91 AKI (95 RON) fuel. Use of 91 AKI (95 RON) fuel will not affect your warranty coverage.

▼ Except STI

Use **unleaded gasoline** with an octane rating of **91 AKI (95 RON) or higher**. If 91 AKI (95 RON) fuel is not readily available, unleaded gasoline with an octane rating of 87 AKI (90 RON) may be temporarily used. For optimum engine performance and driveability, it is recommended that you use premium grade unleaded gasoline.

■ Fuel octane rating:

This octane rating is the average of the Research Octane and Motor Octane numbers and is commonly referred to as the Anti Knock Index (AKI). Refer to "Fuel octane rating" ☞7-3.

■ Fuel capacity:

15.9 US gal (60 liters, 13.2 Imp gal)

■ Engine oil:

Use only the following oils.

- ILSAC GF-4 or GF-5, which can be identified with the ILSAC certification mark (Starburst mark)
- or API classification SN or SM with the words "ENERGY CONSERVING" or "RESOURCE CONSERVING"

For the complete viscosity requirements, refer to "Engine oil" ☞12-4.

■ Engine oil capacity:

▼ STI

4.5 US qt (4.3 liters, 3.8 Imp qt)

▼ Except STI

5.4 US qt (5.1 liters, 4.5 Imp qt)

The indicated oil quantity is only a guideline and is estimated based on a case when the engine oil is changed with an oil filter. After refilling the engine with oil, the oil level should be checked using an oil level gauge. For more details about maintenance and service, refer to "Engine oil" ☞11-12.

■ Cold tire pressure:

Refer to "Tires" ☞12-8.



Subaru of America, Inc., Subaru Plaza,
P.O. Box 6000, Cherry Hill, NJ 08034-6000



FUJI HEAVY INDUSTRIES LTD.
TOKYO, JAPAN

A1190BE-A
Issued December 2013
Printed in USA 1/14
2015A

英語



MSA5M1514A

Vehicles shown on the cover of this booklet
may not be available in all markets. Please
see your Subaru dealer for a Product Brochure
detailing all currently available models.